

National School Transportation Specifications & Procedures



May 2000

NATIONAL SCHOOL TRANSPORTATION SPECIFICATIONS and PROCEDURES

2000 Revised Edition

Recommendations of

THE THIRTEENTH NATIONAL CONFERENCE ON SCHOOL TRANSPORTATION

Central Missouri State University
Warrensburg, Missouri
May 14-18, 2000

Co-Sponsored by:

National Association of State Directors of Pupil Transportation
National Association for Pupil Transportation
National School Transportation Association
School Transportation Section, National Safety Council
School Bus Manufacturers Technical Council
Missouri Safety Center, Central Missouri State University

This Publication is available from: Missouri Safety Center
Central Missouri State University
Humphreys Suite 201
Warrensburg, MO 64093
Phone: (660) 543-4830
Fax: (660) 543-4482

CONTENTS

Foreword	1
About this Document and Guiding Principles	3
Intended Use	4
Interpretations and Interim Committee	5
School Bus Types	6
Bus Chassis Specifications	9
Air Cleaner	11
Axles	11
Brakes: General	11
Brakes: Hydraulic	11
Brakes: Air	12
Bumper:Front	12
Certification	12
Clutch	13
Color	13
Drive Shaft	13
Electrical System	13
Engine Fire Extinguisher	14
Exhaust System	15
Fenders, Front-Type C Vehicles	15
Frame	15
Fuel Tank	16
Governor	16
Heating System, Provision For	16
Horn	16
Instruments and Instrument Panel	16
Oil Filter	17
Openings	18
Passenger Load	18
Power and Grade Ability	18
Retarder System (Optional Equipment)	18
Road Speed Control	18

Shock Absorbers	18
Steering Gear	18
Suspension Systems	19
Throttle	19
Tires and Rims	19
Transmission	19
Turning Radius	20
Undercoating	20
 Bus Body Specifications	 21
Aisle	23
Back-up Warning Alarm	23
Battery	23
Bumper (Front)	23
Bumper (Rear)	23
Ceiling	24
Certification	24
Chains (Tire)	24
Color	24
Construction	24
Crossing Control Arm (Optional)	25
Defrosters	25
Doors	25
Emergency Exits	26
Emergency Equipment	27
Floors	28
Handrails	29
Heating and Air Conditioning Systems	29
Hinges	31
Identification	31
Inside Height	32
Insulation (Optional)	32
Interior	32
Lamps and Signals	33
Metal Treatment	35
Mirrors	35
Mounting	35
Overall Length	36
Overall Width	36
Public Address System	36
Reflective Material	36

Rub Rails	36
Seat and Restraining Barriers	37
Steering Wheel	38
Steps	38
Step Treads	38
Stirrup Steps	39
Stop Signal Arm	39
Storage Compartment	39
Sun Shield	39
Tailpipe	39
Towing Attachment Points	39
Traction Assisting Devices (Optional)	39
Trash Container and Holding Device	40
Undercoating	40
Ventilation	41
Wheelhousing	41
Windows	41
Windshield Washers	41
Windshield Wipers	42
Wiring	42
Specifications for Specially Equipped School Buses	45
Introduction	47
Definition	47
General Requirements	47
Aisles	47
Communications	48
Glazing	48
Identification	48
Passenger Capacity Rating	48
Power Lifts and Ramps	48
Regular Service Entrance	52
Restraining Devices	52
Seating Arrangements	53
Securement and Restraint System for Wheelchair / Mobility Aid and Occupant ...	53
Special Light	57
Special Service Entrance	57
Special Service Entrance Doors	57
Support Equipment and Accessories	58
Technology and Equipment, New	59

Alternative Fuels	61
Introduction	63
General Requirements	63
Characteristics of Alternative Fuels	64
Operations.....	73
Introduction	75
School Bus Use.....	75
State Administration	75
Local School District Administration.....	77
Driver	79
Bus Attendant	82
Maintenance and Service Personnel.....	83
Operational Procedures.....	83
Evaluation of the Pupil Transportation System	102
Transportation Other Than To and From School	103
Special Needs Student Transportation	109
Laws Affecting Special Needs Student Transportation	111
Individualized Education Program (IEP)	113
Individualized Family Service Plan (IFSP) — Team	113
Guidelines.....	113
Confidentiality	119
Development.....	119
Emergency Evacuation of Students with Disabilities.....	120
Extended School Year.....	121
Infants / Toddlers and Preschool Children	123
Introduction	125
Eligibility Criteria.....	125
Transportation Services for Infants and Toddlers with Disabilities	131
Transportation Services for Preschool Children with Disabilities	132
Head Start	133
Guidelines for Infants, Toddlers and Pre-School Children.....	133

School Bus Inspection	145
History	147
State Inspection Programs	147
Inspection Procedure	147
The Criteria	147
School Bus Recommended Out-of-Service Criteria	148
Table 1-Brake Adjustment	155
Table 2-Steering Wheel Free Play	157
Table 3-Handrail Inspection Tool & Procedure	158
Childrens' and Parents' Responsibilities	159
Reference Sources	160

APPENDICES

Appendix A - Terms and Definitions	161
Introduction	163
Appendix B - School Bus Chassis and Body	185
National School Bus Yellow	187
Bus Body Heating System Test	187
Placement of Retroreflective Markings (side view)	196
Placement of Retroreflective Markings (front and back view)	197
Noise Test Procedure	198
Retroreflective Sheeting Daytime Color Specification	199
School Bus Seat Upholstery Fire Block Test	199
Appendix C - Alternative Fuels	203
Bibliography	205
Glossary of Alternative Fuels	206
Alternative Fuels Comparison Chart	208
Appendix D-Specially Equipped School Buses	209
Test for Frontal Impact Crash Worthiness	211
Wheelchair or Mobility Aid Envelope	212
Specifications for Surrogate Wheelchair	221
Vehicle Ramp	225
Appendix, Vehicle	226

Appendix E - School Bus Operations	227
Highway Safety Program Guideline #17	229
School Bus Driver Application	234
Actions to be Taken During	
and Following the Observations of School Bus Routes	236
Guidelines for En Route Emergency Bus Evacuation Procedures	237
Sample Crash Reporting Form	240
Planning School Sites for School Bus Safety	244
Identification and Evaluation of School Bus Route and	
Hazard Marking Systems	247
Checklist for Identifying Potential School Bus Route Fixed Driving Hazards	257
Policies and Procedures for Pupil Management	261
Evaluation Checklist for School Bus Driveways in the Vicinity of the School	262
Pupil Rules	264
Bus Conduct Report	265
How to Cross the Road Safely (When Leaving the Bus)	267
How to Cross the Road Safely (When Boarding the Bus)	268
Recommended Procedures for School Bus Drivers	
at Railroad Grade Crossings	269
Trip Request Form	271
Instructions for Conducting Emergency Exit Drills	272
Evacuation Procedures for Activity Trips and Field Trips	275
Appendix F - Special Needs Transportation	277
Special Education Department Forms	279
Request for Medical Verification of Health Status and Needs	280
Medical Procedure Authorization	281
Pupil Transportation Card — Students with Disabilities	282
Transportation Service Requirements for Passengers with Health Concerns	284
Procedure for Lifting Passengers	287
Characteristics of Disabilities as Defined by IDEA	290
Sample Continuum of Transportation Services for Students with Disabilities	292
IDEA-Part B Final Regulations - Discipline Procedures	293
Transportation Checklist	295
Appendix G - Infants, Toddlers and Pre-Schoolers	298
Definitions	300
Laws Impacting the Transportation of Infants, Toddlers, and Preschool Children	300
Guideline for Safe Transportation of Pre-School Age Children in School Buses	304

Appendix H - Resolutions	307
Resolution to the Sponsoring Organizations (NASDPTS, NAAPT, NSTA, NSC, SBMI, AND CMSU)	309
Resolution to the National Highway Traffic Safety Administration	310
Resolution to the 14th National Conference Interim and Steering Committee	311
Resolution on Advertising	312
Resolutions of Appreciation	313
Resolution on Transporting Students in Vehicles not Meeting School Bus Design and Construction Standard	314
Resolution on Future Passenger Crash Protection in School Buses	315
Resolution on Intelligent Transportation Systems	316
Resolution on Separation of Specifications and Procedures Document	317
Resolution on Federal Funding for New and Existing Safety Programs	318
Resolution on Loading and Unloading Survey	319
Resolution Steering Committee	320
Resolution on Uniform Incident Reporting for Student Travel	321
Resolution on Air Bags	322
Committees	323
Roster of Delegates and Alternates	327
Roster	335

FOREWORD

The 2000 National Conference on School Transportation was the latest in a series beginning in 1939 and continuing in 1945, 1948, 1951, 1954, 1959, 1964, 1970, 1980, 1985, 1990, and 1995. All conferences have been made up of official representatives of State Departments of Education, Public Safety, Motor Vehicles, and Police or other state agencies having statewide responsibilities for the administration of pupil transportation, local school district personnel, contract operators, advisors from industry, and representatives from other interested professional organizations and groups. Each conference has resulted in one or more publications that contain the recommendations of that particular conference.

The recommendation of specifications and procedures for school buses and their operation has been a major purpose of all conferences. The 1939 Conference was called for this sole purpose and formulated a set of recommended standards for school buses of 20 or more passengers. The 1945 Conference revised the 1939 recommendations and added standards for small vehicles of 10 to 18 passengers. Both standards were further revised by the 1948 Conference. There were additional revisions in 1959, and the 1964 Conference added standards for school buses to be used in transporting students with disabilities. In addition to revising standards for larger vehicles, the 1970 Conference refined the standards for school buses designed to transport fewer than 24 passengers.

Other major issues in pupil transportation have received attention at these National Conferences. On several occasions, recommendations concerned primarily with overtaking and passing of school buses were transmitted to the National Committee on Uniform Traffic Laws and Ordinances for consideration in connection with revisions of the Uniform Vehicle Code. The 1948 Conference made recommendations on uniform records and reports for pupil transportation. The major purpose of the 1948 Conference was the formulation of recommendations related to standards and training programs for school bus drivers. These recommendations were revised by the 1959 Conference, and a new publication on the topic was issued. The 1954 Conference gave considerable time to the discussion of the extended use of the school buses in the school program. The 1970 Conference also adopted standards for school bus operation (issued in a separate report).

The 1980 Conference updated the standards for school bus chassis and bodies, rewrote the complete standards for the special education bus, and included definitions for the Type A, B, C and D bus. One of the major tasks of the 1980 Conference was to revise the standards to remove any conflicts with superseding federal regulations, many of which were mandated by sections of the Motor Vehicle and School Bus Safety Amendments of 1974 (Public Law 93-492).

The 1985 Conference updated the standards for school bus chassis, body, special education and operations procedures. A major project was completed in the adoption of a uniform school bus accident report form. This form was designed to standardize school bus accident data reporting throughout the school transportation industry. Major issues such as safety inside the vehicle, loading and unloading, emergency procedures, and special education were discussed with appropriate resolutions passed for future research and implementation.

The 1990 Conference removed the word minimum from the title of the Conference publication. The format of the Conference publication was reorganized into two parts, Standards for School Buses and Standards for Operations. All sub-parts such as accident reporting and special education transportation were incorporated into the section on the school bus or the section on operations.

A major change was incorporated into the procedures for the 1990 Conference. Any mandatory standard could be recommended for a special vote for forwarding action to the appropriate federal agency with a request for rulemaking. This rulemaking request would be an attempt to have the standard, adopted at the Conference, become a federally mandated requirement. For this forwarding action to be approved, any such item had to receive two-thirds affirmative vote. The delegation approved forwarding action on standards for mirrors, emergency exits, accident reporting and special education transportation. This procedural change was carried forward for the 1995 Conference.

The 1995 Conference was the first to begin to address the expanded role of pupil transportation as prescribed in the revised Highway Safety Program Guideline #17 - Pupil Transportation Safety. The revised guidelines became effective May 29, 1991, and this was the first Conference convened since its adoption. Transportation of pre-kindergarten age students including infants and toddlers was addressed for the first time. A comprehensive section dealing with the use of alternative fuels in school bus operations was discussed and included in the publication. A new section, Terms and Definitions, was added to the appendices to promote consistency throughout the industry and consolidate into one resource the acronyms, abbreviations, and standard terms used in the industry. It provided easy access to definitions of terms used or referenced within the document.

The 2000 Conference included significant discussion of the purpose and intended use of the document, which had been known in previous Conferences as the "National Standards for School Transportation." Leading up to the 2000 Conference, arguments were made for retention in the title of the term "Standards" or adoption of the new term "Guidelines." These deliberations were an attempt to accurately describe the document to state and local transportation providers, industry suppliers, governmental oversight agencies, representatives of the legal profession, and other users. The new title that was ultimately approved by the delegates is the "National School Transportation Specifications and Procedures." A significant majority of the delegates believed that this title describes the actual contents and intended use of the document more precisely. The Introduction has been expanded to explain clearly that these specifications for school buses and operational procedures comprise recommendations of the delegates to the states and other potential users of this document. These entities may choose, under their respective regulatory authorities, to adopt all or part of these specifications and procedures into laws or regulations.

Other significant changes or additions adopted by the 2000 Conference delegates included: a new side intrusion test for school bus bodies; a strong recommendation to states to require the use of school buses or buses having equivalent crash protection for all student transportation; reorganization of the operations sections into a more user-friendly format; sanctioning of the recent federal guidelines for seating of pre-school age students; conformance of the procedures for transportation of students with disabilities with updated federal regulations; and, a new section on school bus inspection.

With the enactment in 1966 of the National Traffic and Motor Vehicle Safety Act, the federal government was given responsibility for developing and promulgating motor vehicle safety standards for motor vehicles sold in the United States. These Federal Motor Vehicle Safety Standards (FMVSS) are continually evaluated and revised as needed. Such standards in their present form or as subsequently amended will void any action taken during the 2000 Conference wherever there is a conflict. Whenever specifications and procedures adopted by the 2000 Conference, go beyond, or are in addition to the FMVSS, they remain valid.

The structure for the 2000 Conference and its operating guidelines was carried out by the Steering Committee. Funding for the conference was shared solely by each individual participant of the Steering Committee, Writing Committees and all delegates at the conference.

Charles F. Hood
General Conference Chairperson

ABOUT THIS DOCUMENT

Certain objectives and guiding principles have a vital role in the development of the specifications for school buses and procedures for their operation. These objectives and guiding principles have been reaffirmed and emphasized at the National Conferences since 1939. The two major objectives, safety and efficiency, along with the guiding principles stated herein, have served as guideposts for making decisions regarding the specifications and procedures and in arriving at sound and common agreement.

Adequate state and federal regulations governing school bus specifications and operation provide two key ingredients for the safe, comfortable and efficient transportation of pupils. Safety includes all factors relating to school bus equipment, performance specifications and operational procedures that may directly or indirectly affect the safety and welfare of pupils transported.

Efficiency includes the management of specifications, procurement and maintenance of school buses, the operational practices and procedures of staff consistent with the safety and welfare of pupils and the effective use of financial resources.

GUIDING PRINCIPLES

- A. Federal standards and state specifications for school buses and procedures for their operation should:
 - 1. Be consistent with the objectives of safety and efficiency;
 - 2. Ensure the construction and use of safe buses;
 - 3. Reduce conflicting specifications and procedures among states wherever possible; and
 - 4. Specify exact dimensions where necessary to increase the quality and efficiency of manufacture.

- B. Any adaptation of these national specifications and procedures should be made by states only in order to adjust to local needs and only when such adaptations do not:
 - 1. Conflict with Federal Motor Vehicle Safety Standards (FMVSS);
 - 2. Conflict with the National Highway Traffic Safety Administration's Highway Safety Guide line #17 - Pupil Transportation Safety; and
 - 3. Unduly increase operation or production costs.

- C. State specifications for school buses and operational procedures should be written in terms of the performance desired, thus assuring that the resulting state regulations are enforceable.

- D. Provisions should be made within each state for periodic review and revision of its specifications for school buses and procedures for their operation.

- E. State specifications for school buses and procedures for their operation should allow for state approval of the use of new inventions and improvements that are consistent with safety and efficiency.

- F. State specifications for school buses should provide for a degree of flexibility (consistent with safety and efficiency) to accommodate the various manufacturers.

- G. State specifications for school buses should recognize that the actual design of school buses is a responsibility of the manufacturers.

- H. The current National School Transportation Specifications and Procedures are considered as recommendations to the states. Revisions of these specifications and procedures are made only when evidence indicates that such revisions are needed.

INTENDED USE

These specifications for school buses and procedures for operation are available for states to consider when establishing their standards, specifications, recommendations, and guidelines. As a general rule, state legislatures should confer upon the appropriate state agency or regulatory body the general responsibility for setting up state-wide rules and regulations regarding the specifications for school bus chassis, bodies and equipment and the procedures for school transportation operations.

The specifications and procedures for school transportation appearing in this report represent the official actions of the delegates to the 13th National Conference on School Transportation and comprise recommendations to regulatory authorities or other parties. Except for restatements of federal standards, laws and rules that may be contained herein, these recommendations are not regulatory until they are officially adopted by the appropriate state regulatory authority to become legally effective within that state. It should be noted that some items in this report are informational only and do not constitute "recommendations" of the delegates.

In considering these specifications and procedures for adoption into state regulations, each portion or individual content item should be reviewed by the state to determine its applicability, as recommended by the delegates. The following terms are used throughout this document to define the recommended applicability within states adopting these specifications and procedures:

- A. SHALL - a mandatory condition. Where certain school bus designs, equipment or operations are described with the "shall" stipulation, it is mandatory that all school buses and all school bus operations meet those requirements as written.

Note: The word "shall" also is used when referring to items that are already adopted into federal laws, standards, or regulations.

- B. SHOULD - an advisory condition. Where certain school bus designs, equipment or operations are described with the word "should," such items are considered to be advisable usage. In other words, the item is recommended, but not mandatory for all school buses or all school bus operations.
- C. MAY - a permissive condition. Where certain school bus designs, equipment or operations are described with the word "may," such items are considered for possible usage. However, there is no intent that the item be required for all school buses or all school bus operations.

Recognizing that many of these specifications and procedures (those using the above definition of "shall") are recommended as requirements and will become requirements when they are adopted into regulations by individual states, the principles and guidelines for the intended use of this report are consistent with the following "Statement of Understanding" adopted by the Steering Committee of the 13th National Conference on School Transportation on July 10, 1999 (for inclusion herein). In the context of this overall report, the following statement reminds persons using the report that until these specifications and procedures are adopted into state regulations, either by reference or directly, adherence to their provisions is voluntary:

The purpose of this publication is to serve as a basis for the separate states to establish specifications, rules, and/or regulations for school transportation within those states. This publication is representative of the views of professional practitioners from the states represented at the 13th National Conference on School Transportation. Its emphasis on practices, procedures, and performance encompasses school transportation in total and includes guidelines for school buses and school bus operations. The material contained herein will provide useful guidance for school transportation specialists in each state; however, it does not establish specifications or standards for any state. Use of this publication in part or in its entirety is completely voluntary.

The vehicle specifications contained herein are intended to apply primarily to new vehicles, including all types of school buses as defined in the section entitled "Definitions, School Bus (Type A-1, Type A-2, Type B, Type C and Type D)." It should be noted that vehicles with a capacity of ten (10) or fewer persons, including the driver, cannot be certified as school buses under federal regulations.

States should allow sufficient lead-time between publication of their specifications and the effective date. The effective date should be expressed: "These specifications apply respectively to school bus chassis and bodies placed in production on or after (month, day, year)."

INTERPRETATIONS

Requests for interpretation of these specifications and procedures should be mailed to the chairman of the Interpretations Committee, addressed as follows: D. Leeds Pickering, Program Manager, Wyoming Department of Education, 2300 Capital Ave, 2nd Floor, Cheyenne, Wy 82002-0050.

INTERIM COMMITTEE

The Interim Committee succeeds the Conference Steering Committee between conferences. Requests for modifications of the specifications and procedures and development of new ones should be directed to the chairman of the Interim Committee, addressed as follows: Mr. Charlie Hood, Director, Student Transportation, Florida Department of Education, 325 West Gaines Street, #824, Tallahassee, Florida 32399-0400.

SCHOOL BUS TYPES

A Type "A" school bus is a van conversion or bus constructed utilizing a cutaway front-section vehicle with a left side driver's door. The entrance door is behind the front wheels. This definition includes two classifications: Type A1, with a Gross Vehicle Weight Rating (GVWR) less than or equal to 10,000 pounds; and Type A2, with a GVWR greater than 10,000 pounds.

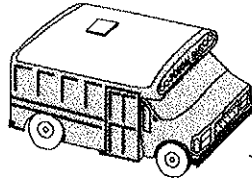

Type A

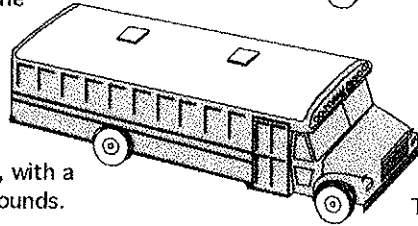
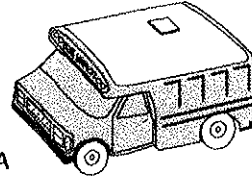

Type A

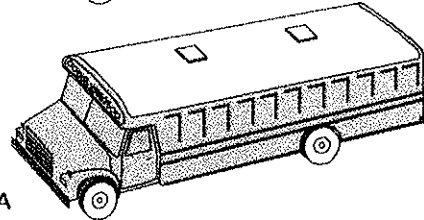

A Type "B" school bus is constructed utilizing a stripped chassis. The entrance door is behind the front wheels. This definition includes two classifications: Type B1, with a GVWR less than or equal to 10,000 pounds; and Type B2, with a GVWR greater than 10,000 pounds.

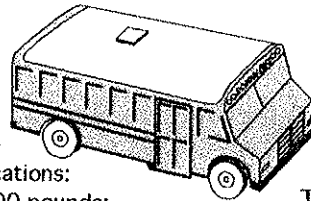

Type B

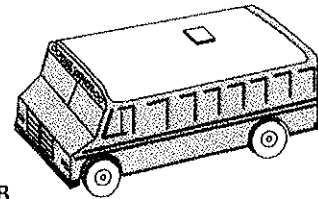

A Type "C" school bus is constructed utilizing a chassis with a hood and front fender assembly. The entrance door is behind the front wheels.

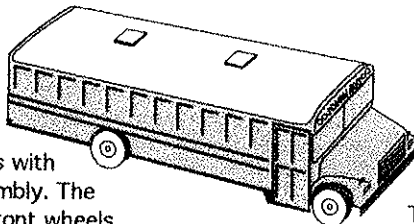

Type C

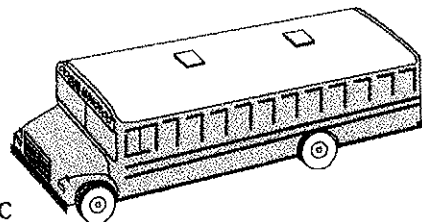

A Type "D" school bus is constructed utilizing a stripped chassis. The entrance door is ahead of the front wheels.

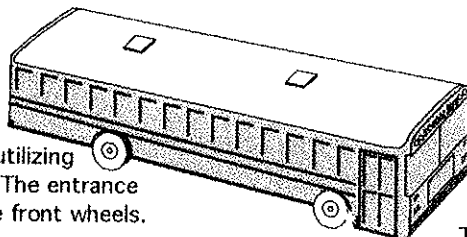

Type D

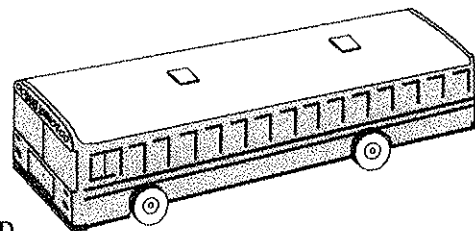

INTRODUCTION TO SCHOOL BUS SPECIFICATIONS

This portion of the report is divided into four sections: Chassis Specifications, Body Specifications, Specifications for Specially Equipped School Buses and Specifications for Alternative Fuel School Buses. If these specifications are adopted by a state or states, special attention must be given to them by the chassis and the body manufacturer, as appropriate or necessary.

Every attempt has been made by the Writing Committees, the Conference itself and the Editing Committee to eliminate conflicts between these specifications and federal regulations. Should conflicts be found to exist or arise through new federal regulations or legally binding interpretations of those regulations, they should be brought to the attention of the Interpretations Committee, who, in turn, will report them to the Interim Committee.

For new vehicles, it is the responsibility of the vehicle manufacturer to certify compliance with applicable federal standards by installing a certification plate or label in the driver's area on each vehicle. However, as the vehicle is maintained over its useful life, it is the responsibility of those who supervise and perform work on the vehicle to assure on-going compliance with all applicable federal and state standards and specifications, as well to coordinate recalls. For this reason, maintenance personnel training, quality components, quality workmanship and thorough maintenance records are essential.

Finally, in order to ensure that specifications are being met by manufacturers, states are urged to adopt and carry out effective pre-delivery inspection programs.

BUS CHASSIS SPECIFICATIONS

BUS CHASSIS
SPECIFICATIONS

BUS CHASSIS SPECIFICATIONS

AIR CLEANER

- A. A dry element type air cleaner shall be provided.
- B. All diesel engine air filters shall include a latch-type restriction indicator that retains the maximum restriction developed during operation of the engine. The indicator should include a reset control so the indicator can be returned to zero when desired.

AXLES

The front and rear axle and suspension systems shall have a gross axle weight rating (GVWR) at ground commensurate with the respective front and rear weight loads that will be imposed by the bus.

BRAKES: GENERAL

- A. The chassis brake system shall conform to the provisions of FMVSS No. 105, No. 106 and No. 121 as applicable.
- B. The anti-lock brake system (ABS), provided in accordance with FMVSS No. 105 or No. 121, shall provide wheel speed sensors for each front wheel and for each wheel on at least one rear axle. The system shall provide anti-lock braking performance for each wheel equipped with sensors. (Four Channel System.)
- C. All brake systems shall be designed to permit visual inspection of brake lining wear without removal of any chassis component(s).
- D. The brake lines, booster-assist lines, and control cables shall be protected from excessive heat, vibration and corrosion and installed in a manner which prevents chafing.
- E. The parking brake system for either air or hydraulic service brake systems may be of a power assisted design. The power parking brake actuator should be a push-pull device located on the instrument panel within seated reach of a 5th percentile female driver. As an option, the parking brake may be set by placing the automatic transmission shift control mechanism in the "park" position.
- F. The power-operated parking brake system may be interlocked to the engine key switch. Once the parking brake has been set and the ignition switch turned to the "off" position, the parking brake cannot be released until the key switch is turned back to the "on" position.

BRAKES: HYDRAULIC

Buses using a hydraulic-assist brake shall be equipped with audible and visible warning signals that provide a continuous warning to the driver of a loss of fluid flow from the primary source and of a failure of the back-up pump system.

BRAKES: AIR

- A. The air pressure supply system shall include a desiccant-type air dryer installed according to the manufacturers' recommendations. The air pressure storage tank system may incorporate an automatic drain valve.
- B. The Chassis manufacturer should provide an accessory outlet for air operated systems installed by the body manufacturer. This outlet shall include a pressure protection valve.
- C. For air brake systems, an air pressure gauge shall be provided in the instrument panel capable of complying with CDL pre-trip inspection requirements.
- D. All air brake-equipped buses may be equipped with a service brake interlock. The parking brake cannot be released until the brake pedal is depressed.
- E. Air brake systems may include a system for anti-compounding of the service brakes and parking brakes.
- F. Air brakes shall have both a visible and audible warning device whenever the air pressure falls below the level where warnings are required under FMVSS No. 121.

BUMPER: FRONT

- A. School buses shall be equipped with a front bumper. The front bumper shall be furnished by the chassis manufacturer for all school bus types by the chassis manufacturer unless there is a specific agreement between the chassis manufacturer and body manufacturer.
- B. The front bumper shall be of pressed steel channel or equivalent material (except Type A buses having a GVWR of 14,500 pounds or less which may be OEM supplied) at least 3/16" thick and not less than 8" wide (high). It shall extend beyond forward-most part of the body, grille, hood, and fenders and shall extend to the outer edges of the fenders at the bumper's top line.
- C. The front bumper, except breakaway bumper ends, shall be of sufficient strength to permit pushing a vehicle of equal gross vehicle weight without permanent distortion to the bumper, chassis or body.
- D. Tow eyes or hooks shall be furnished and attached so they do not project beyond the front bumper. Tow eyes or hooks attached to the frame chassis shall be furnished by the chassis manufacturer. This installation shall be in accordance with the chassis manufacturer's specifications. **NOTE:** Rear tow eyes are addressed in the Bus Body Specifications under Towing Attachment points.
- E. The bumper shall be designed or reinforced so that it will not deform when the bus is lifted by a chain that is passed under the bumper (or through the bumper if holes are provided for this purpose) and attached to both tow eyes. For the purpose of meeting this specifications, the bus shall be empty and positioned on a level, hard surface and both tow eyes shall share the load equally.

CERTIFICATION

The chassis manufacturer, upon request of the state agency having pupil transportation jurisdiction, shall certify that its product meets the state's minimum standards on items not covered by the FMVSS certification requirements of 49 CFR, Part 567.

CLUTCH

- A. Clutch torque capacity shall be equal to or greater than the engine torque output.
- B. A starter interlock shall be installed to prevent actuation of the starter if the clutch pedal is not depressed.

COLOR

- A. The chassis, including wheels and front bumper, shall be black. Body cowl, hood, and fenders shall be in National School Bus Yellow (NSBY.) The flat top surface of the hood may be non-reflective black or NSBY. (See Appendix B.)
- B. Demountable rims, if used, may be silver, gray, white, yellow or black as received from the wheel manufacturer.

DRIVE SHAFT

The drive shaft shall be protected by a metal guard or guards around the circumference of the drive shaft to reduce the possibility of its whipping through the floor or dropping to the ground, if broken.

ELECTRICAL SYSTEM

- A. Battery
 - 1. The storage batteries shall have minimum cold cranking capacity rating (cold cranking amps) equal to the cranking current required for 30 seconds at 0 degrees Fahrenheit and a minimum reserve capacity rating of 120 minutes at 25 amps. Higher capacities may be required, depending upon optional equipment and local environmental conditions.
 - 2. Since all batteries are to be secured in a sliding tray in the body, chassis manufacturers shall mount the battery temporarily on the chassis frame, except that van conversion or cutaway front-section chassis may be secured in accordance with the manufacturer's standard configuration. In these cases, the final location of the battery and the appropriate cable lengths shall be agreed upon mutually by the chassis and body manufacturer. However, in all cases the battery cable provided with the chassis shall have sufficient length to allow some slack.
- B. Alternator
 - 1. All Type A-2 and Type B buses with a GVWR of 15,000 lbs or less shall have a minimum ampere alternator.
 - 2. Type A-2 and Type B buses over 15,000 lbs GVWR and all Type C and Type D buses shall be equipped with a heavy-duty truck or bus-type alternator meeting SAE J 180, having a minimum output rating of 100 amperes or higher, and should produce a minimum current output of 50 percent of the rating at engine idle speed.
 - 3. Buses equipped with an electrically powered wheelchair lift, air conditioning or other

accessories may be equipped with a device that monitors the electrical system voltage and advances the engine idle speed when the voltage drops to, or below, a pre-set level.

4. A belt alternator drive shall be capable of handling the rated capacity of the alternator with no detrimental effect on any other driven components. (See SBMTC; "School Bus Technical Reference," for estimating required alternator capacity.)
5. A direct drive alternator is permissible in lieu of a belt driven alternator.

C. Wiring

1. All wiring shall conform to current applicable recommended practices of the Society of Automotive Engineers (SAE).

All wiring shall use color and at least one other method of identification. The other method shall be either a number code or name code, and each chassis shall be delivered with a wiring diagram that illustrates the wiring of the chassis.

2. The chassis manufacturer shall install a readily accessible terminal strip or plug on the body side of the cowl or in an accessible location in the engine compartment of vehicles designed without a cowl. The strip or plug shall contain the following terminals for the body connections:
 - a. Main 100 amp body circuit;
 - b. Tail lamps;
 - c. Right turn signal;
 - d. Left turn signal;
 - e. Stop lamps;
 - f. Back-up lamps; and
 - g. Instrument panel lights (rheostat controlled by headlamp switch).

D. Circuits

1. An appropriate identifying diagram (color plus a name or number code) for all chassis electrical circuits shall be provided to the body manufacturer for distribution to the end user.
2. The headlight system must be wired separately from the body-controlled solenoid.

E. Daytime Running Lamps (DRL)

A Daytime Running Lamps system meeting chassis manufacturer's specifications may be provided. Additional features may be specified by states, as needed.

ENGINE FIRE EXTINGUISHER

The chassis manufacturer may provide an automatic fire extinguisher system in the engine compartment.

EXHAUST SYSTEM

- A. The exhaust pipe, muffler and tailpipe shall be outside the bus body compartment and attached to the chassis so as not to damage any other chassis component.
 - B. The tailpipe shall be constructed of a corrosion-resistant tubing material at least equal in strength and durability to 16-gauge steel tubing of equal diameter.
 - C. Chassis manufacturers shall furnish an exhaust system with a tailpipe of sufficient length to exit the rear of the bus or at the left side of the bus body no more than 18 inches forward of the front edge of the rear wheel house opening. If designed to exit at the rear of the bus, the tailpipe shall extend at least five inches beyond the end of the chassis frame. If designed to exit to the side of the bus, the tailpipe shall extend at least 48.5 inches (51.5 inches if the body is to be 102 inches wide) outboard from the chassis centerline.
 - 1. On Types C and D vehicles, the tailpipe shall not exit beneath a fuel fill or emergency door exit.
 - 2. Types A and B chassis may be furnished with the manufacturer's standard tailpipe configuration.
- (Note: see also Bus Body Standards: TAILPIPE.)
- D. The exhaust system on a chassis shall be adequately insulated from the fuel system.
 - E. The muffler shall be constructed of corrosion-resistant material.
 - F. The exhaust system on the chassis may be routed to the left of the right frame rail to allow for the installation of a power lift unit on the right side of the vehicle.

FENDERS: FRONT-TYPE C VEHICLES

- A. Total spread of outer edges of front fenders, measured at fender line, shall exceed the total spread of front tires when front wheels are in a straight-ahead position.
- B. Front fenders shall be properly braced and shall not require attachment to any part of the body.

FRAME

- A. The frame (or equivalent) shall be of such design and strength characteristics as to correspond at least to standard practices for trucks of the same general load characteristics which are used for highway service.
- B. Any secondary manufacturer that modifies the original chassis frame shall guarantee the performance of workmanship and materials resulting from such modification.
- C. Frames shall not be modified for the purpose of extending the wheel base.
- D. Holes in top or bottom flanges or side units of the frame, and welding to the frame, shall not be permitted except as provided or accepted by chassis manufacturer.
- E. Frame lengths shall be established in accordance with the design criteria for the complete vehicle.

FUEL TANK

- A. Fuel tank (or tanks) having a minimum 30-gallon capacity shall be provided by the chassis manufacturer. The tank shall be filled and vented to the outside of the body and the fuel filler should be placed in a location where accidental fuel spillage will not drip or drain on any part of the exhaust system.
- B. Fuel lines shall be mounted to the chassis frame in such a manner that the frame provides the maximum possible protections from damage.
- C. The fuel system shall comply with FMVSS No. 301.
- D. Fuel tank(s) may be mounted between the chassis frame rails or outboard of the frame rails on either the left or right side of the vehicle.
- E. The actual draw capacity of each fuel tank shall be a minimum of 83 percent of the tank capacity.
- F. Installation of alternative fuel systems, including fuel tanks and piping from tank to the engine, shall comply with all applicable fire codes in effect on the date of manufacture of the bus.

Installation of LPG tanks shall comply with National Fire Protection Association (NFPA) 58.

GOVERNOR

When the engine is remotely located from the driver, the governor shall be set to limit engine speed to maximum revolutions per minute as recommended by the engine manufacturer, and a tachometer shall be installed so the engine speed may be known to the driver while seated in a normal driving position.

HEATING SYSTEM, PROVISION FOR

The chassis engine shall have plugged openings for the purpose of supplying hot water for the bus heating system. The openings shall be suitable for attaching 3/4 inch pipe thread/hose connectors. The engine shall be capable of supplying coolant at a temperature of at least 170 degrees Fahrenheit at the engine cooling thermostat opening temperature. The coolant flow rate shall be 50 pounds per minute at the return end of 30 feet of one-inch inside diameter automotive hot water heater hose. (See SBMT C-001.)

HORN

The bus shall be equipped with a horn(s) of standard make with each horn capable of producing a complex sound in bands of audio frequencies between 250 and 2,000 cycles per second and tested in accordance with SAE J-377.

INSTRUMENTS AND INSTRUMENT PANEL

- A. The chassis shall be equipped with the instruments and gauges listed below. (Telltale warning lamps in lieu of gauges are not acceptable, except as noted.)
 - 1. Speedometer;
 - 2. Odometer which will give accrued mileage (to seven digits), including tenths of miles;

3. Voltmeter;

(An ammeter with graduated charge and discharge indications is permitted in lieu of a voltmeter; however, when used, the ammeter wiring must be compatible with the current flow of the system.)
4. Oil pressure gauge;
5. Water temperature gauge;
6. Fuel gauge;
7. Upper beam headlamp indicator;
8. Brake indicator gauge (vacuum or air);

(A telltale warning lamp indicator in lieu of a gauge is permitted on a vehicle equipped with a hydraulic-over-hydraulic brake system.)
9. Turn signal indicator; and
10. Glow-plug indicator light where appropriate.

B. All instruments shall be easily accessible for maintenance and repair.

C. The instruments and gauges shall be mounted on the instrument panel so that each is clearly visible to the driver while seated in a normal driving position.

D. The instrument panel shall have lamps of sufficient candlepower to illuminate all instruments, gauges and shift selector indicator for the automatic transmission.

E. Multi-function gauge (MFG)

1. The driver must be able to manually select any displayable function of the gauge on a MFG whenever desired.
2. Whenever an out-of-limits condition that would be displayed on one or more functions of a MFG occurs, the MFG controller should automatically display this condition on the instrument cluster. This should be in the form of an illuminated telltale warning lamp as well as having the MFG automatically display the out-of-limits indications. Should two or more functions displayed on the MFG go out of limits simultaneously, then the MFG should sequence automatically between those functions continuously until the condition(s) are corrected.
3. The use of a MFG does not relieve the need for audible warning devices, where required.

OIL FILTER

An oil filter with a replaceable element shall be provided and connected by flexible oil lines if it is not a built-in or an engine-mounted design. The oil filter shall have a capacity of at least one (1) quart.

OPENINGS

All openings in the floorboard or firewall between chassis and the passenger compartment (e.g., for gearshift selector and parking brakes lever) shall be sealed.

PASSENGER LOAD

- A. Actual gross vehicle weight (GVW) is the sum of the chassis weight plus the body weight, plus the driver's weight, plus total seated pupil weight.

For purposes of calculation, the driver's weight is 150 pounds and the pupil weight is 120 pounds per pupil.

- B. Actual GVW shall not exceed the chassis manufacturer's GVWR for the chassis, nor shall the actual weight carried on any axle exceed the chassis manufacturer's Gross Axle Weight Rating (GAWR.)
- C. The manufacturer's GVWR for a particular school bus shall be furnished by manufacturers in duplicate (unless more copies are requested) to the state agency having pupil transportation jurisdiction. The state agency shall, in turn, transmit such ratings to other state agencies responsible for development or enforcement of state standards for school buses.

POWER AND GRADE ABILITY

GVWR shall not exceed 185 pounds per published net horsepower of the engine at the manufacturer's recommended maximum number of revolutions per minute.

RETARDER SYSTEM (OPTIONAL EQUIPMENT)

A retarder system, if used, shall maintain the speed of a fully loaded school bus at 19.0 mph on a seven percent grade for 3.6 miles.

ROAD SPEED CONTROL

When it is desired to accurately control vehicle maximum speed, a vehicle speed limiter may be utilized.

SHOCK ABSORBERS

The bus shall be equipped with double-action shock absorbers compatible with manufacturer's rated axle capacity at each wheel location.

STEERING GEAR

- A. The steering gear shall be approved by the chassis manufacturer and designed to ensure safe and accurate performance when the vehicle is operated with maximum load and at maximum speed.
- B. If external adjustments are required, steering mechanism shall be accessible to make adjustments.

- C. No changes shall be made in the steering apparatus which are not approved by the chassis manufacturer.
- D. There shall be a clearance of at least two inches between the steering wheel and cowl, instrument panel, windshield, or any other surface.
- E. Power steering is required and shall be of the integral type with integral valves.
- F. The steering system shall be designed to provide a means for lubrication of all wear-points, which are not permanently lubricated.

SUSPENSION SYSTEMS

- A. The capacity of springs or suspension assemblies shall be commensurate with the chassis manufacturer's GVWR.
- B. Rear leaf rear springs shall be of a progressive rate or multi-stage design. Front leaf springs shall have a stationary eye at one end and shall be protected by a wrapped leaf, in addition to the main leaf.

THROTTLE

The force required to operate the throttle shall not exceed 16 pounds throughout the full range of accelerator pedal travel.

TIRES AND RIMS

- A. Rims of the proper size and tires of the proper size and load rating commensurate with the chassis manufacturer's gross vehicle weight rating shall be provided. The use of multi-piece rims and/or tube-type tires shall not be permitted on any school bus ordered after December 31, 1995.
- B. Dual rear tires shall be provided on Type A-2, Type B, Type C and Type D school buses.
- C. All tires on a vehicle shall be of the same size, and the load range of the tires shall meet or exceed the GVWR, as required by FMVSS No. 120.
- D. If the vehicle is equipped with a spare tire and rim assembly, it shall be the same size as those mounted on the vehicle.
- E. If a tire carrier is required, it shall be suitably mounted in an accessible location outside the passenger compartment.

TRANSMISSION

- A. Automatic transmissions shall have no fewer than three forward speeds and one reverse speed. Mechanical shift selectors shall provide a detent between each gear position when the gear selector quadrant and shift selector are not steering-column mounted.
- B. In manual transmissions, second gear and higher shall be synchronized, except when incompatible with engine power. A minimum of three forward speeds and one reverse speed shall be provided.

- C. An electronic control, or similar device, may be installed to ensure that automatic transmissions cannot accidentally be moved out of the “neutral” or “park” gear position while the driver is not seated in the driver’s seat.

TURNING RADIUS

- A. A chassis with a wheelbase of 264 inches or less shall have a right and left turning radius of not more than 42 1/2 feet, curb-to-curb measurement.
- B. A chassis with a wheelbase of 265 inches or more shall have a right and left turning radius of not more than 44 1/2 feet, curb-to-curb measurement.

UNDERCOATING

The chassis manufacturers, or their agents, shall coat the undersides of steel or metallic-constructed front fenders with a rust-proofing compound, for which the compound manufacturer has issued notarized certification of compliance to chassis builder that the compound meets or exceeds all performance and qualitative requirements of paragraph 3.4 of Federal Specification TT-C-520B, using modified tests.

BUS BODY SPECIFICATIONS

SPECIFICATIONS
BUS BODY

BUS BODY SPECIFICATIONS

AISLE

- A. All emergency doors shall be accessible by a 12-inch minimum aisle. The aisle shall be unobstructed at all times by any type of barrier, seat, wheelchair or tiedown, unless a flip seat is installed and occupied. A flip seat in the unoccupied (up) position shall not obstruct the 12-inch minimum aisle to any side emergency door.
- B. The seat backs shall be slanted sufficiently to give aisle clearance of 15 inches at tops of seat backs.

BACK-UP WARNING ALARM

An automatic audible alarm shall be installed behind the rear axle and shall comply with the published Backup Alarm Standards (SAE J994B), providing a minimum of 112 dbA.

BATTERY

- A. The battery is to be furnished by the chassis manufacturer.
- B. When the battery is mounted as described in the "Bus Chassis Specifications," the body manufacturer shall securely attach the battery on a slide-out or swing-out tray in a closed, vented compartment in the body skirt, so that the battery is accessible for convenient servicing from the outside. The battery compartment door or cover shall be hinged at the front or top, and be secured by an adequate and conveniently operated latch or other type fastener. The battery compartment is not required on Type A-1 buses.
- C. Buses may be equipped with a battery shut-off switch. The switch is to be placed in a location not readily accessible to the driver or passengers.

BUMPER: FRONT

On a Type D school bus, if the chassis manufacturer does not provide a bumper, it shall be provided by the body manufacturer. The bumper will conform to the standards described in the "Bus Chassis Specifications."

BUMPER: REAR

- A. The bumper shall be pressed steel channel at least 3/16 inch thick or equivalent strength material (except for Type A buses). Type A-1 buses bumper shall be a minimum of 8 inches wide (high) and Type A-2, B, C and D buses bumper shall be a minimum of 9 1/2 inches wide (high). The bumper shall be of sufficient strength to permit being pushed by another vehicle without permanent distortion.
- B. The bumper shall be wrapped around the back corners of the bus. It shall extend forward at least 12 inches, measured from the rear-most point of the body at the floor line, and shall be flush-mounted to the body sides or protected with an end panel.
- C. The bumper shall be attached to the chassis frame in such a manner that it may be easily removed. It shall be so braced as to withstand impact from the rear or the side. It shall be so attached as to discourage hitching of rides by an individual.

- D. The bumper shall extend at least 1 inch beyond the rear-most part of the body surface measured at the floor line.

CEILING

See Insulation and Interior, this section.

CERTIFICATION

The body manufacturer shall, upon request of the state agency having pupil transportation jurisdiction, certify that its product meets the state's minimum standards on items which are not covered by FMVSS certification requirements of 49 CFR, Part 567.

CHAINS (TIRE)

See Wheelhousing, this section.

COLOR

- A. The school bus body shall be painted National School Bus Yellow (NSBY). (See Appendix B).
- B. The body exterior paint trim shall be black.
- C. Optionally, the roof of the bus may be painted white except that the front and rear roof caps shall remain NSBY. (See illustration in Appendix B, under Reflective Materials.)

CONSTRUCTION

- A. **Side Intrusion Test:** The bus body shall be constructed to withstand an intrusion force equal to the curb weight of the vehicle; but shall not exceed 20,000 pounds, whichever is less. Each vehicle shall be capable of meeting this requirement when tested in accordance with the procedures set forth below.

The complete body structure, or a representative seven-body section mock up with seats installed, shall be load-tested at a location 24 inches plus or minus two inches above the floor line, with a maximum 10-inch diameter cylinder, 48 inches long, mounted in a horizontal plane.

The cylinder shall be placed as close as practical to the mid-point of the tested structure, spanning two internal vertical structural members. The cylinder shall be statically loaded to the required force of curb weight or 20,000 pounds, whichever is less, in a horizontal plane with the load applied from the exterior toward the interior of the test structure. Once the minimum load has been applied, the penetration of the loading cylinder into the passenger compartment shall not exceed a maximum of ten inches from its original point of contact. There can be no separation of lapped panels or construction joints. Punctures, tears or breaks in the external panels are acceptable but are not permitted on any adjacent interior panel.

Body companies shall certify compliance with this intrusion requirement, including test results, if requested.

- B. Construction shall be reasonably dust-proof and watertight.

CROSSING CONTROL ARM

- A. Buses may be equipped with a crossing control arm mounted on the right side of the front bumper. This arm when opened shall extend in a line parallel with the body side and positioned on a line with the right side wheels.
- B. All components of the crossing control arm and all connections shall be weatherproofed.
- C. The crossing control arm shall incorporate system connectors (electrical, vacuum or air) at the gate and shall be easily removable to allow for towing of the bus.
- D. The crossing control arm shall meet or exceed SAE J1133.
- E. The crossing control arm shall be constructed of noncorrosive or nonferrous material or treated in accordance with the body sheet metal specification. (see METAL TREATMENT.)
- F. There shall be no sharp edges or projections that could cause hazard or injury to students.
- G. The crossing control arm shall extend minimum 70 inches (measured from the bumper at the arm assembly attachment point) when in the extended position.
- H. The crossing control arm shall extend simultaneously with the stop arm(s) by means of the stop arm controls.
- I. An automatic recycling interrupt switch should be installed for temporary disabling of the crossing control arm.

DEFROSTERS

- A. Defrosting and defogging equipment shall direct a sufficient flow of heated air onto the wind shield, the window to the left of the driver and the glass in the viewing area directly to the right of the driver to eliminate frost, fog and snow.
- B. The defrosting system shall conform to SAE J381 and J382.
- C. The defroster and defogging system shall be capable of furnishing heated, outside ambient air, except that the part of the system furnishing additional air to the windshield, entrance door and stepwell may be of the recirculating air type.
- D. Auxiliary fans are not considered defrosting or defogging systems.
- E. Portable heaters shall not be used.

DOORS

- A. Service door
 - 1. The service door shall be in the driver's control, designed to afford easy release and to provide a positive latching device on manual operating doors to prevent accidental opening. When a hand lever is used, no part shall come together that will shear or crush fingers. Manual door controls shall not require more than 25 pounds of force to operate at any point throughout the range of operation, as tested on a 10 percent grade both uphill and downhill.

2. The service door shall be located on the right side of the bus, opposite and within direct view of driver.
3. The service door shall have a minimum horizontal opening of 24 inches and a minimum vertical opening of 68 inches. Type A-1 vehicles shall have a minimum opening area of 1,200 square inches.
4. Service door shall be a split-type, sedan-type or jackknife-type. (Split-type door includes any sectioned door which divides and opens inward or outward.) If one section of a split-type door opens inward and the other opens outward, the front section shall open outward.
5. Lower, as well as upper, door panels shall be of approved safety glass. The bottom of each lower glass panel shall not be more than ten inches from the top surface of the bottom step. The top of each upper glass panel shall not be more than three inches from the top of the door. Type A vehicles shall have an upper panel (windows) of safety glass with an area of at least 350 square inches.
6. Vertical closing edges on split-type or folding-type entrance doors shall be equipped with flexible material to protect children's fingers. Type A-1 vehicles may be equipped with the chassis manufacturer's standard entrance door.
7. There shall be no door to the left of the driver on Type B, C or D vehicles. All Type A vehicles may be equipped with the chassis manufacturer's standard left-side door.
8. All doors shall be equipped with padding at the top edge of each door opening. Padding shall be at least three inches wide and one-inch thick and extend the full width of the door opening.
9. On power-operated service doors, the emergency release valve, switch or device to release the service door must be placed above or to the immediate left or right of the service door and clearly labeled.

EMERGENCY EXITS

- A. All installed emergency exits shall comply with the requirements of FMVSS No. 217.
- B. Emergency door requirements
 1. The upper portion of the emergency door shall be equipped with approved safety glazing, the exposed area of which shall be at least 400 square inches. The lower portion of the rear emergency doors on Types A-2, B, C, and D vehicles shall be equipped with a minimum of 350 square inches of approved safety glazing.
 2. There shall be no steps leading to an emergency door.
 3. The emergency door(s) shall be equipped with padding at the top edge of each door opening. Padding shall be at least three inches wide and one-inch thick, and shall extend the full width of the door opening.
 4. There shall be no obstruction higher than 1/4 inch across the bottom of any emergency door opening.

5. The rear emergency window shall have an assisted lifting device that will aid in lifting and holding the rear emergency window open.

C. Emergency exit requirements

Types A,B,C and D vehicles shall be equipped with a total number of emergency exits as follows for the indicated capacities of vehicles. Exits required by FMVSS 217 may be included to comprise the total number of exits specified.

0 to 42 Passengers	= 1 emergency exit per side and 1 roof hatch.
43 to 78 Passengers	= 2 emergency exits per side and 2 roof hatches.
79 to 90 Passengers	= 3 emergency exits per side and 2 roof hatches.

Side emergency exit windows when installed may be vertically hinged on the forward side of the window. No side emergency exit window will be located above a stop arm.

Currently, the minimum requirements of FMVSS 217, when calculated to each capacity of school bus, are as follows and are exceeded by the aforementioned National Specification:

One rear emergency exit door plus additional emergency exits based on the following maximum rated seating capacities:

1 to 45 Passengers	= no additional emergency exits.
46 to 62 Passengers	= 1 left side emergency door or 2 emergency exit windows.
63 to 70 Passengers	= 1 left side emergency door or 2 emergency exit windows, and 1 emergency roof exit.
71 or more Passengers	= 1 left side emergency door or 2 emergency exit windows, and 1 emergency roof exit, plus any combination of door, roof or windows necessary to meet the total amount of emergency exit area required.

One emergency exit door on the left side and a push-out rear window plus additional emergency exits based on the following maximum rated seating capacities:

1 to 57 Passengers	= no additional emergency exits
58 to 74 Passengers	= 1 right side emergency door or 2 emergency door or 2 emergency exit windows.
75 to 82 Passengers	= 1 right side emergency door or 2 emergency exit windows, and 1 emergency roof exit.
83 or more Passengers	= 1 right side emergency door or 2 emergency exit windows, and 1 emergency roof exit, plus any combination of door, roof or windows necessary to meet the total amount of emergency exit area required.

EMERGENCY EQUIPMENT

A. Fire extinguisher

1. The bus shall be equipped with at least one UL-approved pressurized, dry chemical fire extinguisher. The extinguisher shall be mounted (and secured) in a bracket, located in the driver's compartment and readily accessible to the driver and passengers. A pressure gauge shall be mounted on the extinguisher and shall be easily read without moving the extinguisher from its mounted position.

2. The fire extinguisher shall have a total rating of 2A10BC or greater. The operating mechanism shall be sealed with a type of seal that will not interfere with the use of the fire extinguisher.

B. First-aid kit

1. The bus shall have a removable, moisture-proof and dust-proof first aid kit in an accessible place in the driver's compartment. It shall be properly mounted (and secured) and identified as a first aid kit. The location for the first aid kit shall be marked. Contents of first aid kit shall be in compliance with state standards.

2. Suggested contents include:

- 2 - 1 inch x 2 1/2 yards of adhesive tape rolls
- 24 - sterile gauze pads 3 inches x 3 inches
- 100 - 3/4 inch x 3 inches adhesive bandages
- 8 - 2 inch bandage compress
- 10 - 3 inch bandage compress
- 2 - 2 inch x 6 feet sterile gauze roller bandages
- 2 - non-sterile triangular bandages minimum 39 inches x 35 inches x 54 inches with 2 safety pins
- 3 - sterile gauze pads 36 inches x 36 inches
- 3 - sterile eye pads
- 1 - rounded-end scissors
- 1 - pair medical examination gloves
- 1 - mouth-to-mouth airway

C. Body fluid clean-up kit

Each bus shall have a removable and moisture-proof body fluid clean-up kit accessible to the driver. It shall be properly mounted and identified as a body fluid clean-up kit. Contents of body fluid clean-up kit shall be in compliance with state standards.

D. Warning devices

Each school bus shall contain at least three reflectorized triangle road warning devices mounted in an accessible place that meet requirements in FMVSS No. 125.

- E. Any of the emergency equipment may be mounted in an enclosed compartment, provided the compartment is labeled in not less than one-inch letters, identifying each piece of equipment contained therein.

FLOORS

- A. The floor in the under-seat area, including tops of wheelhousings, driver's compartment and toeboard, shall be covered with rubber floor covering or equivalent, having a minimum overall thickness of .125 inch. The driver's area in all Type A buses may be manufacturer's standard flooring and floor covering.
- B. The floor covering in the aisles shall be of aisle-type rubber or equivalent, wear-resistant and ribbed. Minimum overall thickness shall be .187 inch measured from tops of ribs.

- C. The floor covering must be permanently bonded to the floor and must not crack when subjected to sudden changes in temperature. Bonding or adhesive material shall be waterproof and shall be a type recommended by the manufacturer of floor-covering material. All seams must be sealed with waterproof sealer.
- D. On Types B, C and D buses, a flush-mounted, screw-down plate that is secured and sealed shall be provided to access the fuel tank sending unit.

HANDRAILS

At least one handrail shall be installed. The handrail(s) shall assist passengers during entry or exit, and be designed to prevent entanglement, as evidenced by the passage of the NHTSA string and nut test as defined in the School Bus Inspection section, item 11.85.

HEATING AND AIR CONDITIONING SYSTEMS

A. Heating System

1. The heater shall be hot water and/or combustion type.
2. If only one heater is used, it shall be fresh-air or combination fresh-air and recirculation type.
3. If more than one heater is used, additional heaters may be recirculating air type.
4. The heating system shall be capable of maintaining bus interior temperatures as specified in SAE test procedure J2233.
5. Auxiliary fuel-fired heating systems are permitted, provided they comply with the following:
 - a. The auxiliary heating system fuel shall utilize the same type fuel as specified for the vehicle engine;
 - b. The heater(s) may be direct hot air or connected to the engine's coolant system;
 - c. An auxiliary heating system, when connected to the engine's coolant system, may be used to preheat the engine coolant or preheat and add supplementary heat to the bus's heating system;
 - d. Auxiliary heating systems must be installed pursuant to the manufacturer's recommendations and shall not direct exhaust in such a manner that will endanger bus passengers;
 - e. Auxiliary heating systems which operate on diesel fuel shall be capable of operating on #1, #2 or blended diesel fuel without the need for system adjustment;
 - f. The auxiliary heating system shall be low voltage;
 - g. Auxiliary heating systems shall comply with all applicable FMVSSs, including FMVSS No. 301, as well as with SAE test procedures.

6. All forced air heaters installed by body manufacturers shall bear a name plate that indicates the heater rating in accordance with SBMTC-001. The plate shall be affixed by the heater manufacturer and shall constitute certification that the heater performance is as shown on the plate.
7. Heater hoses shall be adequately supported to guard against excessive wear due to vibration. The hoses shall not dangle or rub against the chassis or any sharp edges and shall not interfere with or restrict the operation of any engine function. Heater hoses shall conform to SAE J20c. Heater lines on the interior of bus shall be shielded to prevent scalding of the driver or passengers.
8. Each hot water system installed by a body manufacturer shall include one shut-off valve in the pressure line and one shut-off valve in the return line with both valves at the engine in an accessible location, except that on all Types A and B buses, the valves may be installed in another accessible location.
9. There shall be a water flow regulating valve installed in the pressure line for convenient operation by the driver while seated.
10. All combustion heaters shall be in compliance with current Federal Motor Carrier Safety Regulations.
11. Accessible bleeder valves shall be installed in an appropriate place in the return lines of body company-installed heaters to remove air from the heater lines.
12. Access panels shall be provided to make heater motors, cores and fans readily accessible for service. An outside access panel may be provided for the driver's heater.

B. Air Conditioning (Optional)

The following specifications are applicable to all types of school buses that may be equipped with air conditioning. This section is divided into two parts:

Part 1 covers performance specifications and Part 2 covers other requirements applicable to all buses.

1. Performance Specifications

The installed air conditioning system should cool the interior of the bus down to at least 80 degrees Fahrenheit, measured at a minimum of three points, located four feet above the floor at the longitudinal centerline of the bus. The three points shall be: (1) near the driver's location, (2) at the mid point of the body, and (3) two feet forward of the emergency door, or, for Type D rear-engine buses, two feet forward of the end of the aisle.

The test conditions under which the above performance must be achieved shall consist of: (1) placing the bus in a room (such as a paint booth) where ambient temperature can be maintained at 100 degrees Fahrenheit (2) heat soaking the bus at 100 degrees Fahrenheit with windows open for at least one hour and (3) closing windows, turning on the air conditioner with the engine running at the chassis manufacturer's recommended low idle speed, and cooling the interior of the bus to 80 degrees Fahrenheit or lower within a maximum of 30 minutes while maintaining 100 degrees Fahrenheit outside temperature.

Alternately, and at the user's discretion, this test may be performed under actual summer conditions, which consist of temperatures above 85 degrees Fahrenheit, humidity above 50 percent with normal sun loading of the bus and the engine running at the engine

manufacturer's recommended low idle speed. After a minimum of one hour of heat soaking, the system shall be turned on and must provide a minimum 20 degree temperature drop in the 30-minute time limit.

The manufacturer shall provide facilities for the user or user's representative to confirm that a pilot model of each bus design meets the above performance requirements.

2. Other Requirements

- a. Evaporator cases, lines and ducting (as equipped) shall be designed in such a manner that all condensation is effectively drained to the exterior of the bus below the floor level under all conditions of vehicle movement and without leakage on any interior portion of bus.
- b. Any evaporator or ducting system shall be designed and installed so as to be free of injury-prone projections or sharp edges. Any ductwork shall be installed so that exposed edges face the front of the bus and do not present sharp edges.
- c. On specially equipped school buses, the evaporator and ducting (if used) shall be placed high enough that they will not obstruct occupant securement shoulder strap upper attachment points. This clearance shall be provided along entire length of the passenger area on both sides of the bus interior to allow for potential retrofitting of new wheelchair positions and occupant securement devices throughout the bus.
- d. The body may be equipped with insulation, including sidewalls, roof, firewall, rear, inside body bows and plywood or composite floor insulation to aid in heat dissipation and reflection.
- e. All glass (windshield, service and emergency doors, side and rear windows) may be equipped with maximum integral tinting allowed by federal, state or ANSI standards for the respective locations, except that windows rear of the driver's compartment, if tinted, shall have approximately 28 percent light transmission.
- f. Electrical generating capacity shall be provided to accommodate the additional electrical demands imposed by the air conditioning system.
- g. Roofs may be painted white to aid in heat dissipation. (See Appendix B)

HINGES

All exterior metal door hinges which do not have stainless steel, brass or nonmetallic hinge pins or other designs that prevent corrosion shall be designed to allow lubrication to be channeled to the center 75 percent of each hinge loop without disassembly.

IDENTIFICATION

- A. The body shall bear the words "SCHOOL BUS" in black letters at least eight inches high on both front and rear of the body or on signs attached thereto. Lettering shall be placed as high as possible without impairment of its visibility. Letters shall conform to "Series B" of Standard Alphabets for Highway Signs. "SCHOOL BUS" lettering shall have a reflective background, or as an option, may be illuminated by backlighting.

- B. Required lettering and numbering shall include:
 - 1. District, company name or owner of the bus displayed at the beltline.
 - 2. The bus identification number displayed on the sides, on the rear, and on the front.
- C. Other lettering, numbering or symbols which may be displayed on the exterior of the bus shall be limited to:
 - 1. Bus identification number on the top of the bus, in addition to required numbering on the sides, rear, and front;
 - 2. The location of the battery(ies) identified by the word "BATTERY" or "BATTERIES" on the battery compartment door in two-inch lettering;
 - 3. Symbols or letters not to exceed 64 square inches of total display near the service door, displaying information for identification by the students of the bus or route served;
 - 4. Manufacturer, dealer or school identification or logos;
 - 5. Symbols identifying the bus as equipped for or transporting students with special needs (See Specially Equipped School Bus section);
 - 6. Lettering on the rear of the bus relating to school bus flashing signal lamps or railroad stop procedures; and
 - 7. Identification of fuel type in two-inch lettering adjacent to the fuel filler opening.

INSIDE HEIGHT

Inside body height shall be 72 inches or more, measured metal to metal, at any point on longitudinal centerline from front vertical bow to rear vertical bow. Inside body height of Type A-1 buses shall be 62 inches or more.

INSULATION (OPTIONAL)

- A. If thermal insulation is specified, it shall be fire-resistant, UL approved, with minimum R-value of 5.5. Insulation shall be installed so as to prevent sagging.
- B. If floor insulation is required, it shall be five ply nominal 5/8 inch-thick plywood, and it shall equal or exceed properties of the exterior-type softwood plywood, C-D Grade, as specified in the standard issued by U.S. Department of Commerce. When plywood is used, all exposed edges shall be sealed. Type A-1 buses may be equipped with nominal 1/2 inch-thick plywood or equivalent material meeting the above requirements. Equivalent material may be used to replace plywood, provided it has an equal or greater insulation R value, deterioration, sound abatement and moisture resistance properties.

INTERIOR

- A. The interior of bus shall be free of all unnecessary projections, which include luggage racks and attendant handrails, to minimize the potential for injury. This specification requires inner lining

on ceilings and walls. If the ceiling is constructed to contain lap joints, the forward panel shall be lapped by rear panel and exposed edges shall be beaded, hemmed, flanged or otherwise treated to minimize sharp edges. Buses may be equipped with a storage compartment for tools, tire chains and/or tow chains. (see STORAGE COMPARTMENT.)

- B. Interior overhead storage compartments may be provided if they meet the following criteria:
 - 1. Meet head protection requirements of FMVSS No. 222, where applicable;
 - 2. Have a maximum rated capacity displayed for each compartment;
 - 3. Be completely enclosed and equipped with latching doors which must be sufficient to withstand a force of five times the maximum rated capacity of the compartment;
 - 4. Have all corners and edges rounded with a minimum radius of one-inch or padded equivalent to door header padding;
 - 5. Be attached to the bus sufficiently to withstand a force equal to twenty times the maximum rated capacity of the compartment; and
 - 6. Have no protrusions greater than 1/4 inch.
- C. The driver's area forward of the foremost padded barriers will permit the mounting of required safety equipment and vehicle operation equipment.
- D. Every school bus shall be constructed so that the noise level taken at the ear of the occupant nearest to the primary vehicle noise source shall not exceed 85 dbA when tested according to the procedure in Appendix B.

LAMPS AND SIGNALS

- A. Interior lamps shall be provided which adequately illuminate the aisle and the stepwell. The stepwell light shall be illuminated by a service door-operated switch, to illuminate only when headlights and clearance lights are on and the service door is open.
- B. Body instrument panel lights shall be controlled by an independent rheostat switch.
- C. School bus alternately flashing signal lamps
 - 1. The bus shall be equipped with two red lamps at the rear of the vehicle and two red lamps at the front of the vehicle.
 - 2. In addition to the four red lamps described above, four amber lamps shall be installed so that one amber lamp is located near each red signal lamp, at the same level, but closer to the vertical centerline of bus. The system of red and amber signal lamps shall be wired so that amber lamps are energized manually, and red lamps are automatically energized (with amber lamps being automatically de-energized) when stop signal arm is extended or when bus service door is opened. An amber pilot light and a red pilot light shall be installed adjacent to the driver controls for the flashing signal lamp to indicate to the driver which lamp system is activated.
 - 3. The area around the lenses of alternately flashing signal lamps extending outward from the edge of the lamps three inches (+/-1/4 inch) to the sides and top and minimum one-inch to the bottom, shall be black in color on the body or roof area against which the signal lamp is seen (from distance of 500 feet along axis of the vehicle). Visors or

hoods, black in color, with a minimum depth of four inches may be provided. (See also Appendix B.)

4. Red lamps shall flash at any time the stop signal arm is extended.
5. All flashers for alternately flashing red and amber signal lamps shall be enclosed in the body in a readily accessible location.

D. Turn signal and stop/tail lamps

1. Bus body shall be equipped with amber rear turn signal lamps that are at least seven inches in diameter or, if a shape other than round, a minimum 38 square inches of illuminated area and shall meet SAE specifications. These signal lamps must be connected to the chassis hazard warning switch to cause simultaneous flashing of turn signal lamps when needed as a vehicular traffic hazard warning. Turn signal lamps are to be placed as wide apart as practical and their centerline shall be a maximum of 12 inches below the rear window. Type A-1 conversion vehicle lamps must be at least 21 square inches in lens area and must be in the manufacturer's standard color.
2. Buses shall be equipped with amber side-mounted turn signal lights. The turn signal lamp on the left side shall be mounted rearward of the stop signal arm and the turn signal lamp on the right side shall be mounted rearward of the service door.
3. Buses shall be equipped with four combination red stop/tail lamps.
 - a. Two combination lamps with a minimum diameter of seven inches, or if a shape other than round, a minimum 38 square inches of illuminated area shall be mounted on the rear of the bus just inside the turn signal lamps.
 - b. Two combination lamps with a minimum diameter of four inches, or if a shape other than round, a minimum of 12 square inches of illuminated area, shall be placed on the rear of the body between the beltline and the floor line. The rear license plate lamp may be combined with one lower tail lamp. Stop lamps shall be activated by the service brakes and shall emit a steady light when illuminated. Type A-1 buses with bodies supplied by chassis manufacturer May be equipped with manufacturer's standard stop and tail lamps.

E. On buses equipped with a monitor for the front and rear lamps of the school bus, the monitor shall be mounted in full view of the driver. If the full circuit current passes through the monitor, each circuit shall be protected by a fuse or circuit breaker against any short circuit or intermittent shorts.

F. An optional white flashing strobe light may be installed on the roof of a school bus, at a location not to exceed 1/3 the body length forward from the rear of the roof edge. The light shall have a single clear lens emitting light 360 degrees around its vertical axis and may not extend above the roof more than maximum legal height. A manual switch and a pilot light shall be included to indicate when the light is in operation. Optionally, the strobe light may be mounted on the roof in the area directly over the restraining barrier on the driver's side, may be wired to activate with the amber alternately flashing signal lamps, continuing through the full loading or unloading cycle, and may be equipped with an override switch to allow activation of the strobe at any time for use in inclement weather.

- G. The bus body shall be equipped with two white rear backup lamp signals that are at least four-inches in diameter or, if a shape other than round, a minimum of 13 square inches of illuminated area, meeting FMVSS No. 108. If backup lamps are placed on the same horizontal line as the brake lamps and turn signal lamps, they shall be to the inside.

METAL TREATMENT

- A. All metal used in construction of the bus body shall be zinc-coated or aluminum-coated or treated by an equivalent process before the bus is constructed. Included are such items as structural members, inside and outside panels, door panels and floor sills. Excluded are such items as door handles, grab handles, interior decorative parts and other interior plated parts.
- B. All metal parts that will be painted, in addition to the above requirements, shall be chemically cleaned, etched, zinc phosphate-coated and zinc chromate-or epoxy-primed, or the metal may be conditioned by equivalent process.
- C. In providing for these requirements, particular attention shall be given to lapped surfaces, welded connections of structural members, cut edges on punched or drilled hole areas in sheet metal, closed or box sections, unvented or undrained areas and surfaces subjected to abrasion during vehicle operation.
- D. As evidence that the above requirements have been met, samples of materials and sections used in the construction of the bus body shall not lose more than 10 percent of material by weight when subjected to a 1,000-hour salt spray test as provided for in the latest revision of ASTM Standard B-117.

MIRRORS

- A. The interior mirror shall be either clear view laminated glass or clear view glass bonded to a backing which retains the glass in the event of breakage. The mirror shall have rounded corners and protected edges. All Type A buses shall have a minimum of a six-inch x 16-inch mirror and Types B, C and D buses shall have a minimum of a six-inch x 30-inch mirror.
- B. Each school bus shall be equipped with exterior mirrors meeting the requirements of FMVSS No. 111. Mirrors shall be easily adjustable but shall be rigidly braced so as to reduce vibration.
- C. Heated external mirrors may be used.

MOUNTING

- A. The chassis frame shall support the rear body cross member. The bus body shall be attached to chassis frame at each main floor sill, except where chassis components interfere, in such a manner as to prevent shifting or separation of the body from the chassis under severe operating conditions.
- B. Isolators shall be installed at all contact points between the body and the chassis frame on Types A-2, B, C and D buses, and shall be secured by a positive means to the chassis frame or body to prevent shifting, separation, or displacement of the isolators under severe operating conditions.

OVERALL LENGTH

Overall length of the bus shall not exceed 45 feet, excluding accessories.

OVERALL WIDTH

Overall width of bus shall not exceed 102 inches, excluding accessories.

PUBLIC ADDRESS SYSTEM

- A. Buses may be equipped with an AM/FM/audio and/or public address system having interior and exterior speakers.
- B. No internal speakers, other than the driver's communication systems, may be installed within four feet of the driver's seat back in its rearmost upright position.

REFLECTIVE MATERIAL (see also Reflective Material, Appendix B.)

- A. The front and/or rear bumper may be marked diagonally 45 degrees down to centerline of pavement with two-inch $\pm 1/4$ inch wide strips of non-contrasting reflective material.
- B. The rear of bus body shall be marked with strips of reflective NSBY material to outline the perimeter of the back of the bus using material which conforms with the requirements of FMVSS No. 131, Table 1. The perimeter marking of rear emergency exits per FMVSS No. 217 and/or the use of reflective "SCHOOL BUS" signs partially accomplishes the objective of this requirement. To complete the perimeter marking of the back of the bus, strips of at least one 3/4-inch-reflective NSBY material shall be applied horizontally above the rear windows and above the rear bumper, extending from the rear emergency exit perimeter, marking outward to the left and right rear corners of the bus. Vertical strips shall be applied at the corners connecting these horizontal strips.
- C. "SCHOOL BUS" signs, if not of lighted design, shall be marked with reflective NSBY material comprising background for lettering of the front and/or rear "SCHOOL BUS" signs.
- D. Sides of bus body shall be marked with at least one 3/4-inch-reflective NSBY material, extending the length of the bus body and located (vertically) between the floor line and the beltline.
- E. Signs, if used, placed on the rear of the bus relating to school bus flashing signal lamps or railroad stop procedures may be of reflective material as specified by each state.

RUB RAILS

- A. There shall be one rub rail located on each side of the bus at seat cushion level which extends from the rear side of the entrance door completely around the bus body (except the emergency door or any maintenance access door) to the point of curvature near the outside cowl on the left side.
- B. There shall be one additional rub rail located on each side at, or no more than 10 inches above, the floor line. The rub rail shall cover the same longitudinal area as the upper rub rail, except at the wheelhousings, and it shall extend only to the radii of the right and left rear corners.
- C. Both rub rails shall be attached at each body post and at all other upright structural members.
- D. Each rub rail shall be four inches or more in width in their finished form, shall be constructed of 16-gauge steel or suitable material of equivalent strength and shall be constructed in corrugated or ribbed fashion.

- E. Both rub rails shall be applied outside the body or outside the body posts. (Pressed-in or snap-on rub rails do not satisfy this requirement.) For Type A-1 vehicles using the body provided by the chassis manufacturer or for Types A-2, B, C and D buses using the rear luggage or the rear engine compartment, rub rails need not extend around the rear corners.
- F. There shall be a rub rail or equivalent bracing located horizontally at the bottom edge of the body side skirts.

SEAT AND RESTRAINING BARRIERS

A. Passenger Seating

1. All seats shall have a minimum cushion depth of 15 inches and must comply with all requirements of FMVSS No. 222. School bus design capacities shall be in accordance with 49 CFR, Part 571.3 and FMVSS No. 222.
2. All restraining barriers and passenger seats shall be constructed with materials that enable them to meet the criteria contained in the School Bus Seat Upholstery Fire Block Test. (See Appendix B.)
3. Each seat leg shall be secured to the floor by a minimum of two bolts, washers and nuts. Flange-head nuts may be used in lieu of nuts and washers, or seats may be track-mounted in conformance with FMVSS No. 222. If track seating is installed, the manufacturer shall supply minimum and maximum seat spacing dimensions applicable to the bus, which comply with FMVSS No. 222. This information shall be on a label permanently affixed to the bus.
4. All seat frames attached to the seat rail shall be fastened with two bolts, washers and nuts or flange-head nuts.
5. All school buses (including Type A) shall be equipped with restraining barriers which conform to FMVSS No. 222.
6. A flip-up seat may be installed at any side emergency door, provided that it conforms with FMVSS No. 222 and aisle clearance requirements of FMVSS 217. The flip-up seat shall be free of sharp projections on the underside of the seat bottom. The underside of the flip-up seat bottoms shall be padded or contoured to reduce the possibility of clothing being snagged or personal injury during use. Flip-up seats shall be constructed to prevent passenger limbs from becoming entrapped between the seat back and the seat cushion when the seat is in the upright position. The seat cushion shall be designed to rise to a vertical position automatically when it is not occupied.

B. Pre-School Age Seating

When installed, all passenger seats designed to accommodate a child or infant carrier seat shall comply with FMVSS No. 225. These seats shall be in compliance with NHTSA's "Guideline for the Safe Transportation of Pre-school Age Children in School Buses."

C. Driver Seat

1. The driver's seat supplied by the body company shall be a high back seat with a minimum seat back adjustable to 15 degrees, without requiring the use of tools, and a head restraint to accommodate a 95th percentile adult male, as defined in FMVSS No. 208. The driver's seat shall be secured with nuts, bolts and washers or flanged-head nuts.
2. Type A buses may use utilize the standard driver's seat provided by the chassis manufacturer.

D. Driver Restraint System

A Type 2 lap/shoulder belt shall be provided for the driver. The assembly shall be equipped with an automatic locking retractor for the continuous belt system. On all buses except Type A equipped with a standard chassis manufacturer's driver's seat, the lap portion of the belt system shall be guided or anchored to prevent the driver from sliding sideways under it. The lap/shoulder belt shall be designed to allow for easy adjustment in order to fit properly and to effectively protect drivers varying in size from 5th percentile adult female to 95th percentile adult male.

STEERING WHEEL

(See Chassis section.)

STEPS

- A. The first step at service door shall be not less than ten inches and not more than 14 inches from the ground when measured from the top surface of the step to the ground, based on standard chassis specifications, except that on Type D vehicles, the first step at the service door shall be 12 inches to 16 inches from the ground. On chassis modifications which may result in increased ground clearance (such as four-wheel drive) an auxiliary step may be provided to compensate for the increase in ground-to-first-step clearance. The auxiliary step is not required to be enclosed.
- B. Step risers shall not exceed a height of ten inches. When plywood is used on a steel floor or step, the riser height may be increased by the thickness of the plywood.
- C. Steps shall be enclosed to prevent accumulation of ice and snow.
- D. Steps shall not protrude beyond the side body line.

STEP TREADS

- A. All steps, including the floor line platform area, shall be covered with 3/16 inch rubber floor covering or other materials equal in wear and abrasion resistance to top grade rubber.
- B. The metal back of the tread shall be permanently bonded to the step tread material.
- C. Steps, including the floor line platform area, shall have a one 1/2-inch nosing that contrasts in color by at least 70 percent measured in accordance with the contrasting color specification in 36 CFR, Part 1192 ADA, Accessibility Guidelines for Transportation Vehicles.
- D. Step treads shall have the following characteristics:
 - 1. Special compounding for good abrasion resistance and coefficient of friction of at least 0.6 for the step surface, and 0.8 for the step nosing;
 - 2. Flexibility so that it can be bent around a 1/2 inch mandrel both at 130 degrees Fahrenheit and 20 degrees Fahrenheit without breaking, cracking or crazing; and
 - 3. A durometer hardness of 85 to 95.

STIRRUP STEPS

Unless the windshield and lamps are not easily accessible from the ground, there may be at least one folding stirrup step or recessed foothold and suitably located handles on each side of the front of the body for easy accessibility for cleaning. Steps are permitted in or on the front bumper in lieu of the stirrup steps if the windshield and lamps are easily accessible for cleaning from that position.

STOP SIGNAL ARM

The stop signal arm(s) shall comply with the requirements of FMVSS No. 131.

STORAGE COMPARTMENT (Optional)

A storage container for tools, tire chains, and/or tow chains may be located either inside or outside the passenger compartment. If inside, it shall have a cover capable of being securely latched and fastened to the floor, convenient to either the service door or the emergency door. (The seat cushion may not serve this purpose.)

SUN SHIELD

- A. An interior adjustable transparent sun shield, with a finished edge and not less than six inches X 30 inches for Types B, C and D vehicles, shall be installed in a position convenient for use by the driver.
- B. On all Type A buses, the sun shield (visor) shall be installed according to the manufacturer's standard.

TAILPIPE

- A. The tailpipe may be flush with, with but shall not extend out more than two inches beyond, the perimeter of the body for side-exit pipe or the bumper for rear-exit pipe.
- B. The tailpipe shall exit to the left of the emergency exit door in the rear of the vehicle or to the left side of the bus in front or behind the rear drive axle. The tailpipe exit location on all Types A-1 or B-1 buses may be according to the manufacturer's standard. The tailpipe shall not exit beneath any fuel filler location or beneath any emergency door.

TOWING ATTACHMENT POINTS

Optional tow eyes, hooks or other devices may be furnished on the rear and attached so they do not project beyond the rear bumper. Tow eyes or hooks for attachment to the rear of the chassis frame shall be furnished by either the chassis or body manufacturer. The installation shall be in accordance with the chassis manufacturer's specifications. (Note: Type A buses are exempt from this requirement for front tow hooks or eyes.)

TRACTION ASSISTING DEVICES (Optional)

- A. Where required or used, sanders shall:

1. Be of hopper cartridge-valve type;
2. Have a metal hopper with all interior surfaces treated to prevent condensation of moisture;
3. Be of at least 100 pound (grit) capacity;
4. Have a cover on the filler opening of hopper, which screws into place, thereby sealing the unit airtight;
5. Have discharge tubes extending to the front of each rear wheel under the fender;
6. Have non-clogging discharge tubes with slush-proof, non-freezing rubber nozzles;
7. Be operated by an electric switch with a telltale pilot light mounted on the instrument panel;
8. Be exclusively driver-controlled; and
9. Have a gauge to indicate that the hopper needs refilling when it reaches one-quarter full.

B. Automatic traction chains may be installed.

TRASH CONTAINER AND HOLDING DEVICE (Optional)

Where requested or used, the trash container shall be secured by a holding device that is designed to prevent movement and to allow easy removal and replacement; and it shall be installed in an accessible location in the driver's compartment, not obstructing passenger use of the service door.

UNDERCOATING

A. Entire underside of bus body, including floor sections, cross member and below-floor-line side panels, shall be coated with rust-proofing material for which the material manufacturer has issued a notarized certification of compliance to the bus body builder that materials meet or exceed all performance and qualitative requirements of paragraph 3.4 of Federal Specification TT-C-520b, using modified test procedures* for the following requirements:

1. Salt spray resistance--pass test modified to 5 percent salt and 1000 hours;
2. Abrasion resistance--pass; and
3. Fire resistance--pass

* Test panels are to be prepared in accordance with paragraph 4.6.12 of TT-C-520b with modified procedure requiring that the test be made on a 48-hour air-cured film at a thickness recommended by the material manufacturer.

B. The undercoating material shall be applied with suitable airless or conventional spray equipment to the recommended film thickness and shall show no evidence of voids in the cured film.

VENTILATION

- A. Auxiliary fans shall meet the following requirements:
 - 1. Fans for left and right sides shall be placed in a location where they can be adjusted for maximum effectiveness and where they do not obstruct vision to any mirror. Note: Type A buses may be equipped with one fan.
 - 2. Fans shall be of six-inch nominal diameter.
 - 3. Fan blades shall be covered with a protective cage. Each fan shall be controlled by a separate switch.
- B. The bus body shall be equipped with a suitably controlled ventilating system of sufficient capacity to maintain proper quantity of air under operating conditions without having to open windows except in extremely warm weather.
- C. Static-type, non-closeable exhaust ventilation shall be installed in a low-pressure area of the roof.
- D. Roof hatches designed to provide ventilation in all types of exterior weather conditions may be provided.

WHEELHOUSING

- A. The wheelhousing opening shall allow for easy tire removal and service.
- B. Wheel housings shall be attached to the floor sheets in such a manner so as to prevent any dust, water or fumes from entering the body. Wheel housings shall be constructed of at least 16-gauge steel.
- C. The inside height of the wheel housings above the floor line shall not exceed 12 inches.
- D. The wheel housings shall provide clearance for installation and use of tire chains on single and dual (if so equipped) power-driving wheels.
- E. No part of a raised wheelhousing shall extend into the emergency door opening.

WINDOWS

- A. Each side window, other than emergency exits designated to comply with FMVSS No. 217, shall provide an unobstructed opening of at least nine inches high but not more than 13 inches high and at least 22 inches wide, obtained by the lowering the window. One side window on each side of the bus may be less than 22 inches wide.
- B. Optional tinted and/or frost-free glazing may be installed in all doors, windows and windshields consistent with federal, state and local regulations.

WINDSHIELD WASHERS

- A windshield washer system shall be provided.

WINDSHIELD WIPERS

- A. A two-speed or variable speed windshield wiping system, with an intermittent feature, shall be provided.
- B. The wipers shall be operated by one or more air or electric motors of sufficient power to operate the wipers. If one motor is used, the wipers shall work in tandem to give full sweep of windshield.

WIRING

- A. All wiring shall conform to current SAE standards.
- B. Circuits:
 - 1. Wiring shall be arranged in circuits, as required, with each circuit protected by a fuse or circuit breaker. A system of color and number coding shall be used and an appropriate identifying diagram shall be provided to the end user, along with the wiring diagram provided by the chassis manufacturer. The wiring diagrams shall be specific to the bus model supplied and shall include any changes to wiring made by the body manufacturer. Chassis wiring diagrams shall be supplied to the end user. A system of color- and number-coding shall be used on buses. The following body interconnecting circuits shall be color-coded as noted:

<u>FUNCTION</u>	<u>COLOR</u>
Left Rear Directional Lamp	Yellow
Right Rear Directional Lamp	Dark Green
Stop Lamps	Red
Back-up Lamps	Blue
Tail Lamps	Brown
Ground	White
Ignition Feed, Primary Feed	Black

The color of the cables shall correspond to SAE J 1128.

- 2. Wiring shall be arranged in at least six regular circuits as follows:
 - a. Head, tail, stop (brake) and instrument panel lamps;
 - b. Clearance lamps and stepwell lamps that shall be actuated when the service door is open;
 - c. Dome lamps;
 - d. Ignition and emergency door signal;
 - e. Turn signal lamps; and
 - f. Alternately flashing signal lamps.
- 3. Any of the above combination circuits may be subdivided into additional independent circuits.

4. Heaters and defrosters shall be wired on an independent circuit.
 5. Whenever possible, all other electrical functions (such as sanders and electric-type windshield wipers) shall be provided with independent and properly protected circuits.
 6. Each body circuit shall be coded by number or letter on a diagram of circuits and shall be attached to the body in a readily accessible location.
- C. The entire electrical system of the body shall be designed for the same voltage as the chassis on which the body is mounted.
 - D. All wiring shall have an amperage capacity exceeding the design load by at least 25 percent. All wiring splices are to be done at an accessible location and noted as splices on the wiring diagram.
 - E. A body wiring diagram of a size that can easily be read shall be furnished with each bus body or affixed in an area convenient to the electrical accessory control panel.
 - F. The body power wire shall be attached to a special terminal on the chassis.
 - G. All wires passing through metal openings shall be protected by a grommet.
 - H. Wires not enclosed within the body shall be fastened securely at intervals of not more than 18 inches. All joints shall be soldered or joined by equally effective connectors, which shall be water-resistant and corrosion-resistant.

SPECIFICATIONS
for
SPECIALLY
EQUIPPED
SCHOOL BUSES

SPECIFICATIONS
for
SPECIALLY
EQUIPPED
SCHOOL BUSES

SPECIFICATIONS FOR SPECIALLY EQUIPPED SCHOOL BUSES

INTRODUCTION

Equipping buses to accommodate students with disabilities is dependent upon the needs of the passengers. While one bus may be fitted with a lift, another may have lap belts installed to secure child seats. Buses so equipped are not to be considered a separate class of school bus, but simply a regular school bus that is equipped for special accommodations.

The specifications in this section are intended to be supplementary to specifications in the chassis and body sections. In general, specially equipped buses shall meet all the requirements of the preceding sections plus those listed in this section. It is recognized by the entire industry that the field of special transportation is characterized by varied needs for individual cases and by a rapidly emerging technology for meeting those needs. A flexible, "common sense" approach to the adoption and enforcement of specifications for these vehicles, therefore, is prudent.

As defined by the Code of Federal Regulations (CFR) 49§571.3, "Bus means a motor vehicle with motive power, except a trailer, designed for carrying more than ten persons" (eleven or more including the driver). This definition also embraces the more specific category, *school bus*. Vehicles with 10 or fewer passenger positions (including the driver) cannot be classified as buses. For this reason, the federal vehicle classification *multipurpose passenger vehicle* (CFR 49 § 571.3), or MPV, must be used by manufacturers for these vehicles in lieu of the classification *school bus*. This classification system does not preclude state or local agencies or these national specifications from requiring compliance of school bus-type MPVs with the more stringent federal standards for school buses. The following specifications address modifications as they pertain to school buses that, with standard seating arrangements prior to modification, would accommodate eleven or more including the driver. If by addition of a power lift, mobile seating device positions or other modifications, the capacity is reduced such that vehicles become MPVs, the intent of these specifications is to require these vehicles to meet the same specifications they would have had to meet prior to such modifications, and such MPVs are included in all references to school buses and requirements for school buses which follow.

DEFINITION

A specially equipped school bus is any school bus that is designed, equipped or modified to accommodate students with special needs.

GENERAL REQUIREMENTS

- A. School buses designed for transporting students with special transportation needs shall comply with National School Transportation Specifications and Procedures and with Federal Motor Vehicle Safety Standards (FMVSS) applicable to their Gross Vehicle Weight Rating (GVWR) category.
- B. Any school bus to be used for the transportation of children who are confined to a wheelchair or other mobile positioning device, or who require life-support equipment that prohibits use of the regular service entrance, shall be equipped with a power lift, unless a ramp is needed for unusual circumstances related to passenger needs.

AISLES

All school buses equipped with a power lift shall provide a minimum 30-inch aisle leading from any wheelchair/mobility aid position to at least one emergency exit. A wheelchair securement position shall never be

located directly in front of a power lift door location. It is understood that, when provided, the lift service door is considered an emergency exit.

COMMUNICATIONS

All school buses that are used to transport individuals with disabilities should be equipped with a two-way electronic voice communication system that can be used at any point in the vehicle's route. Where no such service exists, vehicles would be exempt.

GLAZING

Tinted glazing may be installed in all doors, windows and windshields consistent with federal, state and local regulations.

IDENTIFICATION

Buses with power lifts used for transporting individuals with disabilities shall display the International Symbol of Accessibility below the window line. Such emblems shall be white on blue or black background, shall not exceed 12 square inches in size, and shall be of a high-intensity reflectorized material meeting Federal Highway Administration (FHWA) FP-85 Standards.

PASSENGER CAPACITY RATING

In determining the passenger capacity of a school bus for purposes other than actual passenger load (e.g., vehicle classification or various billing/reimbursement models), any location in a school bus intended for securement of an occupied wheelchair/mobility aid during vehicle operations are regarded as four designated seating positions. Similarly, each lift area may be regarded as four designated seating positions.

POWER LIFTS AND RAMPS

A. The power lift shall be located on the right side of the bus body when not extended. Exception: The lift may be located on the left side of the bus if, and only if, the bus is primarily used to deliver students to the left side of one-way streets.

1. A ramp device may be used in lieu of a mechanical lift if the ramp meets all the requirements of the Americans with Disabilities Act (ADA) as found in 36 CFR §1192.23 Vehicle ramp. (See Appendix D.)
2. A ramp device that does not meet the specifications of ADA but does meet the specifications of paragraph c of this section may be installed and used, when, and only when, a power lift system is not adequate to load and unload students having special and unique needs. A readily accessible ramp may be installed for emergency exit use. If stowed in the passenger compartment, the ramp must be properly secured and placed away from general passenger contact. It must not obstruct or restrict any aisle or exit while in its stowed or deployed position.
3. All vehicles covered by this specification shall provide a level-change mechanism or boarding device (e.g., lift or ramp) complying with paragraph 2 or 3 of this section with sufficient clearances to permit a wheelchair or other mobility aid user to reach a securement location.

B. Vehicle lift

1. Design loads. The design load of the lift shall be at least 600 pounds. Working parts, such as cables, pulleys and shafts, which can be expected to wear, and upon which the lift depends for support of the load, shall have a safety factor of at least six, based on the ultimate strength of the material. Non-working parts, such as platform, frame and attachment hardware that would not be expected to wear, shall have a safety factor of at least three, based on the ultimate strength of the material.

Lift capacity. The lifting mechanism and platform shall be capable of lifting at least 800 pounds.

2. Controls

- (a) Requirements

Controls shall be provided that enable the operator to activate the lift mechanism from either inside or outside the bus. The controls may be interlocked with the vehicle brakes, transmission or door, or they may provide other appropriate mechanisms or systems to ensure the vehicle cannot be moved when the lift is not stowed and so the lift cannot be deployed unless the interlocks or systems are engaged. The lift shall deploy to all levels (e.g., ground, curb and intermediate positions) normally encountered in the operating environment. Where provided, each control for deploying, lowering, raising and stowing the lift and lowering the roll-off barrier shall be of a momentary contact type requiring continuous manual pressure by the operator and shall not allow improper lift sequencing when the lift platform is occupied. The controls shall allow reversal of the lift operation sequence, such as raising or lowering a platform that is part way down, without allowing an occupied platform to fold or retract into the stowed position.

- (b) Exception

Where the lift is designed to deploy with its long dimension parallel to the vehicle axis which pivots into or out of the vehicle while occupied (i.e., "rotary lift"), the requirements of this paragraph prohibiting the lift from being stowed while occupied, shall not apply if the stowed position is within the passenger compartment and the lift is intended to be stowed while occupied.

3. Emergency operation

The lift shall incorporate an emergency method of deploying, lowering to ground level with a lift occupant, and raising and stowing the empty lift if the power to the lift fails. No emergency method, manual or otherwise, shall be capable of being operated in a manner that could be hazardous to the lift occupant or to the operator when operated according to the manufacturer's instructions and shall not permit the platform to be stowed or folded when occupied, unless the lift is a rotary lift and is intended to be stowed while occupied. No manual emergency operation shall require more than two minutes to lower an occupied wheelchair to ground level.

4. Power or equipment failure

Platforms stowed in a vertical position, and deployed platforms when occupied, shall have provisions to prevent their deploying, falling or folding any faster than 12 inches per second or their dropping of an occupant in the event of a single failure of any load-carrying component.

5. Platform barriers

The lift platform shall be equipped with barriers to prevent any of the wheels of a wheel chair or mobility aid from rolling off the platform during its operation. A movable barrier or inherent design feature shall prevent a wheelchair or mobility aid from rolling off the edge closest to the vehicle until the platform is in its fully raised position. Each side of the lift platform that extends beyond the vehicle in its raised position shall have a barrier with a minimum height of one and 1/2 inches. Such barriers shall not interfere with maneuvering into or out of the aisle. The loading-edge barrier (outer barrier), which functions as a loading ramp when the lift is at ground level, shall be sufficient when raised or closed, or a supplementary system shall be provided, to prevent a power wheelchair or mobility aid from riding over or defeating it. The outer barrier of the lift shall automatically raise or close, or a supplementary system shall automatically engage, and remain raised, closed or engaged at all times that the platform is more than three inches above the roadway or sidewalk and the platform is occupied. Alternatively, a barrier or system may be raised, lowered, opened, closed, engaged or disengaged by the lift operator, provided an interlock or inherent design feature prevents the lift from rising unless the barrier is raised or closed or the supplementary system is engaged.

6. Platform surface

The platform surface shall be free of any protrusions over 1/4 inch high and shall be slip resistant. The platform shall have a minimum clear width of 28 1/2 inches at the platform, a minimum clear width of 30 inches measured from two inches above the platform surface to 30 inches above the surface of the platform, and a minimum clear length of 48 inches measured from two inches above the surface of the platform to 30 inches above the surface of the platform. (See "Wheelchair or Mobility Aid Envelope" figure in Appendix D.)

7. Platform gaps

Any openings between the platform surface and the raised barrier shall not exceed 5/8 inches in width. When the platform is at vehicle floor height with the inner barrier (if applicable) down or retracted, gaps between the forward lift platform edge and the vehicle floor shall not exceed 1/2 inch horizontally and 5/8 inch vertically. Platforms on semi-automatic lifts may have a handhold not exceeding 1 1/2 inches by 4 1/2 inches located between the edge barriers.

8. Platform entrance ramp

The outboard entrance ramp or loading-edge barrier used as a ramp and the transition plate from the inboard edge of the platform to the vehicle floor shall not exceed a slope of 1:8, measured on level ground, for a maximum rise of three inches, and the transition from roadway or sidewalk to ramp may be vertical without edge treatment up to 1/4 inch. Thresholds between 1/4 inch and 1/2 inch high shall be beveled with a slope no greater than 1:2.

9. Platform deflection

The lift platform (not including the entrance ramp) shall not deflect more than three degrees (exclusive of vehicle roll or pitch) in any direction between its unloaded position and its position when loaded with 600 pounds applied through a 26 inches by 26 inches test pallet at the centroid of the platform.

10. Platform movement

No part of the platform shall move at a rate exceeding six inches per second while lowering and lifting an occupant, and shall not exceed 12 inches per second during deploying or stowing. This requirement does not apply to the deployment or stowage cycles of lifts that are manually deployed or stowed. The maximum platform horizontal and vertical acceleration when occupied shall be 0.3 g.

11. Boarding direction

The lift shall permit both inboard and outboard facing of wheelchair and mobility aid users.

12. Use by standees

Lifts shall accommodate persons who are using walkers, crutches, canes or braces, or who otherwise have difficulty using steps. The platform may be marked to indicate a preferred standing position.

13. Handrails

Platforms on lifts shall be equipped with handrails on two sides, which move in tandem with the lift, and which shall be graspable and provide support to standees throughout the entire lift operation. Handrails shall have a usable component at least eight inches long with the lowest portion a minimum of 30 inches above the platform and the highest portion a maximum of 38 inches above the platform. The handrails shall be capable of withstanding a force of 100 pounds concentrated at any point on the handrail without permanent deformation of the rail or its supporting structure. The handrail shall have a cross-sectional diameter between 1 1/4 inches and 1 1/2 inches or shall provide an equivalent grasping surface, and have eased edges with corner radii of not less than 1/8 inches. Handrails shall be placed to provide a minimum 1 1/2 inches knuckle clearance from the nearest adjacent surface. Handrails shall not interfere with wheelchair or mobility aid maneuverability when entering or leaving the vehicle.

14. Circuit breaker

A resettable circuit breaker shall be installed between the power source and the lift motor if electrical power is used. It shall be located as close to the power source as possible, but not within the passenger/driver compartment.

15. Excessive pressure

Lift design shall prevent excessive pressure that could damage the lift system when the platform is fully lowered or raised or that could jack the vehicle.

16. Documentation

The following information shall be provided with each vehicle equipped with a lift:

- (1) A phone number where information can be obtained about installation, repair and parts. (Detailed written instructions and a parts list shall be available upon request.)

- (2) Detailed instructions regarding use of the lift and readily visible when the lift door is open, including a diagram showing the proper placement and positioning of wheelchair/mobility aids on lift.

17. Training materials

The lift manufacturer shall make available training materials to ensure the proper use and maintenance of the lift. These may include instructional videos, classroom curriculum, system test results or other related materials.

18. Identification and certification

Each lift shall be permanently and legibly marked or shall incorporate a non-removable label or tag that states that it conforms to all applicable requirements of the current National School Transportation Specifications and Procedures. In addition, the lift manufacturer or an authorized representative, upon request of the original titled purchaser, shall provide a notarized Certificate of Conformance, either original or photocopied, which states that the lift system meets all the applicable requirements of the current National School Transportation Specifications and Procedures.

C. Vehicle ramp

1. If a ramp is used, it shall be of sufficient strength and rigidity to support the special device, occupant and attendant(s). It shall be equipped with a protective flange on each longitudinal side to keep the special device on the ramp.
2. Floor of the ramp shall be constructed of non-skid material.
3. Ramp shall be equipped with handles and shall be of weight and design to permit one person to put the ramp in place and return it to its storage place.
4. Ramps used for emergency evacuation purposes may be installed in raised floor buses by manufacturers. They shall not be installed as a substitute for a lift when a lift is capable of servicing the need.

REGULAR SERVICE ENTRANCE

- A. On power lift-equipped vehicles, steps shall be the full width of the step well, excluding the thickness of the doors in the open position.
- B. A suitable device shall be provided to assist passengers during ingress or egress. This device shall allow for easy grasping or holding and shall have no openings or pinch points that might entangle clothing, accessories or limbs.

RESTRAINING DEVICES

- A. On power lift-equipped vehicles, seat frames may be equipped with attachments or devices to which belts, restraining harnesses or other devices may be attached. Attachment framework or anchorage devices, if installed, shall conform to FMVSS No. 210.

- B. Belt assemblies, if installed, shall conform to FMVSS No. 209.
- C. Child restraint systems, which are used to facilitate the transportation of children who in other modes of transportation would be required to use a child, infant or booster seat, shall conform to FMVSS No. 213.

SEATING ARRANGEMENTS

Flexibility in seat spacing to accommodate special devices shall be permitted to meet passenger requirements. All seating shall be forward-facing.

SECUREMENT AND RESTRAINT SYSTEM FOR WHEELCHAIR/MOBILITY AID AND OCCUPANT

For purposes of better understanding the various aspects and components of this section, the term *securement* or phrase *securement system* is used exclusively in reference to the device(s) which secures the wheelchair/mobility aid. The term *restraint* or phrase *restraint system* is used exclusively in reference to the device(s) used to restrain the occupant of the wheelchair/mobility aid. The phrase *securement and restraint system* is used to refer to the total system that secures and restrains both the wheelchair/mobility aid and the occupant.

- A. Securement and restraint system—general
 - 1. The Wheelchair/Mobility Aid Securement and Occupant Restraint System shall be designed, installed and operated to accommodate passengers in a forward-facing orientation within the bus and shall comply with all applicable requirements of FMVSS No. 222. Gurney-type devices shall be secured parallel to the side of the bus.
 - 2. The securement and restraint system, including the system track, floor plates, pockets or other anchorages shall be provided by the same manufacturer or shall be certified to be compatible by manufacturers of all equipment/systems used.
 - 3. When a wheelchair/mobility aid securement device and an occupant restraint share a common anchorage, including occupant restraint designs that attach the occupant restraint to the securement device or the wheelchair/mobility aid, the anchorage shall be capable of withstanding the loads of both the securement device and the occupant restraint applied simultaneously, in accordance with FMVSS No. 222. (See §B and §C of this section.)
 - 4. When a wheelchair/mobility aid securement device (webbing or strap assembly) is shared with an occupant restraint, the wheelchair/mobility aid securement device (webbing or strap assembly) shall be capable of withstanding a force twice the amount specified in §4.4(a) of FMVSS No. 209. (See §B and §C of this section.)
 - 5. The bus body floor and sidewall structures where the securement and restraint system anchorages are attached shall have equal or greater strength than the load requirements of the system(s) being installed.
 - 6. The occupant restraint system shall be designed to be attached to the bus body either directly or in combination with the wheelchair/mobility aid securement system, by a

method which prohibits the transfer of weight or force from the wheelchair/mobility aid to the occupant in the event of an impact.

7. When an occupied wheelchair/mobility aid is secured in accordance with the manufacturer's instructions, the securement and restraint system shall limit the movement of the occupied wheelchair/mobility aid to no more than two inches in any direction under normal driving conditions.
8. The securement and restraint system shall incorporate an identification scheme that will allow for the easy identification of the various components and their functions. It shall consist of one of the following, or a combination thereof:
 - a. The wheelchair/mobility aid securement (webbing or strap assemblies) and the occupant restraint belt assemblies shall be of contrasting color or color shade.
 - b. The wheelchair/mobility aid securement device (webbing or strap assemblies) and occupant restraint belt assemblies may be clearly marked to indicate the proper wheelchair orientation in the vehicle, and the name and location for each device or belt assembly, i.e., front, rear, lap belt, shoulder belt, etc.
9. All attachment or coupling devices designed to be connected or disconnected frequently shall be accessible and operable without the use of tools or other mechanical assistance.
10. All securement and restraint system hardware and components shall be free of sharp or jagged areas and shall be of a non-corrosive material or treated to resist corrosion in accordance with §4.3(a) of FMVSS No. 209.
11. The securement and restraint system shall be located and installed such that when an occupied wheelchair/mobility aid is secured, it does not block access to the lift door.
12. A device for storage of the securement and restraint system shall be provided. When the system is not in use, the storage device shall allow for clean storage of the system, shall keep the system securely contained within the passenger compartment, shall provide reasonable protection from vandalism and shall enable the system to be readily accessed for use.
13. The entire securement and restraint system, including the storage device, shall meet the flammability standards established in FMVSS No. 302.
14. Each securement device (webbing or strap assembly) and restraint belt assembly shall be permanently and legibly marked or shall incorporate a non-removable label or tag that states that it conforms to all applicable FMVSS requirements, as well as the current National School Transportation Specifications and Procedures. In addition, the system manufacturer, or an authorized representative, upon request by the original titled purchaser, shall provide a notarized Certificate of Conformance, either original or photocopied, which states that the wheelchair/mobility aid securement and occupants' restraint system meets all requirements as specified in FMVSS No. 222 and the current National School Transportation Specifications and Procedures.
15. The following information shall be provided with each vehicle equipped with a securement and restraint system:

- a. A phone number where information can be obtained about installation, repair, and parts. (Detailed written instructions and a parts list shall be available upon request.)
 - b. Detailed instructions regarding use, including a diagram showing the proper placement of the wheelchair/mobility aids and positioning of securement devices and occupant restraints, including correct belt angles.
16. The system manufacturer shall make available training materials to ensure the proper use and maintenance of the wheelchair/mobility aid securement and occupant restraint system. These may include instructional videos, classroom curriculum, system test results or other related materials.

B. Wheelchair/mobility aid securement system

1. Each location for the securement of a wheelchair/mobility aid shall have a minimum of four anchorage points. A minimum of two anchorage points shall be located in front of the wheelchair/mobility aid and a minimum of two anchorage points shall be located in the rear. The securement anchorages shall be attached to the floor of the vehicle and shall not interfere with passenger movement or present any hazardous condition.
2. Each securement system location shall have a minimum clear floor area of 30 inches by 48 inches. Additional floor area may be required for some applications. Consultation between the user and the manufacturer is recommended to ensure the adequate area is provided.
3. The securement system shall secure common wheelchair/mobility aids and shall be able to be attached easily by a person who has average dexterity and who is familiar with the system and wheelchair/mobility aid.
4. As installed, each securement anchorage shall be capable of withstanding a minimum force of 3,000 pounds when applied as specified in FMVSS No. 222. When more than one securement device shares a common anchorage, the anchorage shall be capable of withstanding the force indicated above, multiplied by the number of securement devices sharing that anchorage.
5. Each securement device, if incorporating webbing or a strap assembly, shall comply with the requirements for Type 1 lap belt systems, in accordance with §4.2, §4.3, and §4.4(a) of FMVSS No. 209.
6. The securement system shall secure the wheelchair/mobility aid in such a manner that the attachments or coupling hardware will not become detached when any wheelchair/mobility aid component deforms, when one or more tires deflate, and without intentional operation of a release mechanism (e.g., a spring clip on a securement hook).
7. Each securement device (webbing or strap assembly) shall be capable of withstanding a minimum force of 2,500 pounds when tested in accordance with FMVSS No. 209.
8. Each securement device (webbing or strap assembly) shall provide a means of adjustment, per the manufacturer's design, to remove slack from the device or assembly.

C. Occupant restraint system

1. A Type 2 lap/shoulder belt restraint system that meets all applicable requirements of

FMVSS Nos. 209 and 210 shall provide for restraint of the occupant.

2. The occupant restraint system shall be made of materials that do not stain, soil or tear an occupant's clothing, and shall be resistant to water damage and fraying.
3. Each restraint system location shall have not less than one anchorage of manufacturer's design for the upper end of the upper torso restraint.

The anchorage for each occupant's upper torso restraint shall be capable of withstanding a minimum force of 1,500 pounds when applied as specified in FMVSS No. 222.

4. Each wheelchair/mobility aid location shall have not less than two floor anchorages for the occupant pelvic restraint and the connected upper torso restraint.
 - a. Each floor anchorage shall be capable of withstanding a minimum force of 3,000 pounds when applied as specified in FMVSS No. 222.
 - b. When more than one occupant restraint shares a common anchorage, the anchorage shall be capable of withstanding a minimum force of 3,000 pounds multiplied by the number of occupant restraints sharing the common anchorage in accordance with FMVSS No. 222.
5. Each floor and wall anchorage that secures the occupant restraint to the vehicle which is not permanently attached, shall be of a "positive latch" design and shall not allow for any accidental disconnection.

D. Dynamic testing

1. The wheelchair/mobility aid securement and occupant restraint system shall be subjected to and successfully pass a dynamic sled test at a minimum impact speed/deceleration of 30 mph/20g's.
2. The dynamic test shall be performed by experienced personnel using an impact simulator with proven ability to provide reliable, accurate test results that can be replicated.
3. The dynamic test shall be performed in accordance with the procedures set forth in Appendix A of SAE J2249: "Test for Frontal Impact Crash Worthiness."
4. The wheelchair/mobility aid used for testing purposes shall be a rigid, reusable surrogate wheelchair that complies with the requirements of Appendix D of SAE J2249: "Specification for Surrogate Wheelchair."
5. The dynamic test shall be performed using system assemblies, components and attaching hardware that are identical to the final installation in type, configuration and positioning. The body structure at the anchorage points may be simulated for the purpose of the sled test.
6. When tested, the wheelchair/mobility aid securement and occupant restraint system shall pass the criteria specified in Section 6.2 of SAE J2249: "Performance Requirements of Frontal Sled Impact Test." Following is an abridged summary of the criteria presented in Appendix D.
 - a. Retain the test dummy in the test wheelchair and on the test sled with the test wheelchair in an upright position.

- b. Do not show any fragmentation or complete separation of any load carrying part.
- c. Do not allow the horizontal excursions of the test dummy and the test wheelchair to exceed specified limits.
- d. Prevent the test wheelchair from imposing forward loads on the test dummy.
- e. Allow removal of the test dummy and the test wheelchair subsequent to the test, without the use of tools.

SPECIAL LIGHT

Doorways in which lifts are installed shall have for use during lift operation a special light providing a minimum of two foot-candles of illumination measured on the floor of the bus immediately adjacent to the lift and on the lift when deployed at the vehicle floor level.

SPECIAL SERVICE ENTRANCE

- A. Power lift-equipped bodies shall have a special service entrance to accommodate the power lift.

Exception: If the lift is designed to operate within the regular service entrance, and is capable of stowing such that the regular service entrance is not blocked in any way, and that persons entering or exiting the bus are not impeded in any way, a special service entrance shall not be required.

- B. The special service entrance and door shall be located on the right side of the bus and shall be designed so as not to obstruct the regular service entrance.

Exception: A special service entrance and door may be located on the left side of the bus only if the bus is used primarily to deliver students to the left side of one-way streets and its use is limited to that function.

- C. The opening may extend below the floor through the bottom of the body skirt. If such an opening is used, reinforcements shall be installed at the front and rear of the floor opening to support the floor and give the same strength as other floor openings.
- D. A drip molding shall be installed above the opening to effectively divert water from the entrance.
- E. Door posts and headers at the entrance shall be reinforced sufficiently to provide support and strength equivalent to the areas of the side of the bus not used for the special service entrance.

SPECIAL SERVICE ENTRANCE DOORS

- A. A single door or double doors may be used for the special service entrance.
- B. A single door shall be hinged to the forward side of the entrance unless doing so would obstruct the regular service entrance. If the door is hinged to the rearward side of the doorway, the door shall utilize a safety mechanism which will prevent the door from swinging open should the primary door latch fail. If double doors are used, the system shall be designed to prevent the door(s) from being blown open by the wind resistance created by the forward motion of the bus, and/or shall incorporate a safety mechanism to provide secondary protection should the primary

latching mechanism(s) fail.

- C. All doors shall have positive fastening devices to hold doors in the “open” position.
- D. All doors shall be weather sealed.
- E. When manually operated dual doors are provided, the rear door shall have at least a one-point fastening device to the header. The forward-mounted door shall have at least three one-point fastening devices. One shall be to the header, one to the floor line of the body, and the other shall be into the rear door. The door and hinge mechanism shall be of a strength that is greater than or equivalent to the emergency exit door.
- F. Door materials, panels and structural strength shall be equivalent to the conventional service and emergency doors. Color, rub rail extensions, lettering and other exterior features shall match adjacent sections of the body.
- G. Each door shall have windows set in rubber that are visually similar in size and location to adjacent non-door windows. Glazing shall be of the same type and tinting (if applicable) as standard fixed glass in other body locations.
- H. Door(s) shall be equipped with a device that will actuate an audible or flashing signal located in the driver’s compartment when the door(s) is not securely closed and the ignition is in the “on” position.
- I. A switch shall be installed so that the lifting mechanism will not operate when the lift platform door(s) is closed.
- J. Special service entrance doors shall be equipped with padding at the top edge of the door opening. Padding shall be at least three inches wide and one inch thick and shall extend the full width of the door opening.

SUPPORT EQUIPMENT AND ACCESSORIES

- A. Each bus that is set up to accommodate wheelchair/mobility aids or other assistive or restraint devices that utilize belts shall contain at least one belt cutter properly secured in a location within reach of the driver while belted into his/her driver’s seat. The belt cutter shall be durable and designed to eliminate the possibility of the operator or others being cut during use.
- B. Special equipment or supplies that are used on the bus for mobility assistance, health support or safety purposes shall meet any local, federal or engineering standards that may apply, including proper identification.

Equipment that may be used for these purposes includes, but is not limited to:

1. Wheelchairs and other mobile seating devices. (See section on Securement and Restraint System for Wheelchair/Mobility Aid and Occupant.)
2. Crutches, walkers, canes and other ambulating devices.
3. Medical support equipment. This may include respiratory devices such as oxygen bottles (which should be no larger than 22 cubic feet for liquid oxygen and 38 cubic feet for compressed gas) or ventilators. Tanks and valves should be located and positioned to

protect them from direct sunlight, bus heater vents or other heat sources. Other equipment may include intravenous and fluid drainage apparatus.

- C. All portable equipment and special accessory items, including the equipment listed above, shall be secured at the mounting location to withstand a pulling force of five times the weight of the item or shall be retained in an enclosed, latched compartment. The compartment shall be capable of withstanding forces applied to its interior equal to five times the weight of its contents without failure of the box's integrity and securement to the bus. Exception: If these specifications provide specific requirements for securement of a particular type of equipment, the specific specification shall prevail (e.g., wheelchairs).

TECHNOLOGY AND EQUIPMENT, NEW

It is the intent of these specifications to accommodate new technologies and equipment that will better facilitate the transportation of students with special needs. When a new technology, piece of equipment or component is desired to be applied to the school bus and it meets the following criteria, it is acceptable:

- A. The technology, equipment or component shall not compromise the effectiveness or integrity of any major safety system. (Examples of safety systems include, but are not limited to, compartmentalization, the eight-lamp warning system, emergency exits and the yellow color scheme.)
- B. The technology, equipment or component shall not diminish the safety of the interior of the bus.
- C. The technology, equipment or component shall not create additional risk to students who are boarding or exiting the bus or are in or near the school bus loading zone.
- D. The technology, equipment or component shall not require undue additional activity and/or responsibility for the driver.
- E. The technology, equipment or component shall generally increase efficiency and/or safety of the bus, generally provide for a safer or more pleasant experience for the occupants and pedestrians in the vicinity of the bus or shall generally assist the driver and make his/her many tasks easier to perform.

ALTERNATIVE FUELS

ALTERNATIVE FUELS

ALTERNATIVE FUELS

INTRODUCTION

This section is designed to be used as an overview of the alternative fuels being utilized for school transportation. It is not designed to replace current applicable federal, state, manufacturing or safety specifications that may exceed requirements within this section. There may be advancements in engineering and improvements in equipment fabrication methods and operating practices that differ from those specifically called for in this section. Such deviations or improvements may provide safety and may meet the intent of, and be compatible with, this section. Entities wishing to purchase alternative fuel school buses should use this section only as a starting point. More detailed specifications, including specific design and performance criteria and safety specifications, should be researched by prospective purchasers of alternative-fuel school buses.

GENERAL REQUIREMENTS

Alternative fuel school buses shall meet the following requirements:

- A. Chassis shall meet all specifications previously mentioned in BUS CHASSIS SPECIFICATIONS.
- B. Chassis shall meet all applicable Federal Motor Vehicle Safety Standards (FMVSS).
- C. The fuel system integrity shall meet the specified leakage performance standards when impacted by a moving contoured barrier in accordance with test conditions specified in FMVSS No. 301 or FMVSS No. 303, as applicable.
- D. Original equipment manufacturers (OEMs) and conversion systems using compressed natural gas (CNG) shall comply with National Fire Protection Association (NFPA) Specification 52 A, "Compressed Natural Gas Vehicular Fuel Systems," in effect at the time of installation. Fuel systems using liquefied petroleum gas (LPG) shall comply with NFPA Specification 58 A "Liquefied Petroleum Gases Engine Fuel Systems" in effect at the time of installation.
- E. All alternative fuel buses shall be capable of traveling not less than 200 miles with a full load, except those powered by electricity shall be capable of traveling not less than 80 miles.
- F. Natural gas-powered buses shall be equipped with an interior/exterior gas detection system. All natural gas-powered buses shall be equipped with an automatic or manual fire detection and suppression system.
- G. All materials and assemblies used to transfer or store alternative fuels shall be installed outside the passenger/driver compartment.
- H. All Types C and D buses using alternative fuels shall meet the same base requirements of BUS CHASSIS SPECIFICATIONS for Power and Gradeability i.e., at least one published net horse power per each 185 pounds of Gross Vehicle Weight Rating (GVWR.)
- I. The total weight shall not exceed the GVWR when loaded to rated capacity.
- J. The manufacturer supplying the alternative fuel equipment must provide the owner and operator with adequate training and certification in fueling procedures, scheduled maintenance, trouble shooting and repair of alternative fuel equipment.

- K. All fueling equipment shall be designed specifically for fueling motor vehicles and shall be certified by the manufacturer as meeting all applicable federal, state and industry standards.
- L. All on-board fuel supply containers shall meet all appropriate requirements of the American Society for Mechanical Engineering (ASME) code, DOT regulations or applicable FMVSSs and NFPA standards.
- M. All fuel supply containers shall be securely mounted to withstand a static force of eight times their weight in any direction.
- N. All safety devices that discharge to the atmosphere shall be vented to the outside of the vehicle. The discharge line from the safety relief valve on all school buses shall be located in a manner appropriate to the characteristics of the alternative fuel. Discharge lines shall not pass through the passenger compartment.
- O. A positive, quick-acting (1/4 turn) shut-off control valve shall be installed in each gaseous fuel supply line, as close as possible to the fuel supply containers. The valve controls shall be placed in a location easily operable from the exterior of the vehicle. The location of the valve controls shall be clearly marked on the exterior surface of the bus.
- P. An electrical grounding system shall be required for grounding of the fuel system during maintenance-related venting.

CHARACTERISTICS OF ALTERNATIVE FUELS

For the purpose of this section, alternative fuels refer to the specific fuels listed below. A brief description of each fuel and the advantages and disadvantages of each fuel are shown. (Also see Appendix C, Alternative Fuels Comparison Chart.)

Note: Two other more exotic fuels are being examined: hydrogen and solar power. These two energy sources are in their infancy as alternative fuels for motor vehicles and are not covered within the scope of this section.

A. Liquid alternative fuels

I. Methanol

Methanol, a liquid at normal ambient temperatures, is colorless and is made primarily from natural gas or coal. Extensive experiments have been conducted with automobile and truck engines powered by methanol. There are a number of urban transit bus fleets currently using methanol. California has experience with methanol as an alternative fuel for school buses through its School Bus Demonstration Project. The findings clearly determined methanol fuel to be costly to operate and unreliable.

a. Advantages:

- (1) The principal advantage of methanol is that the emissions produced are quite low in particulates and NOx.
- (2) Methanol mixes with gasoline and can be used as M85, which is 15 percent gasoline and 85 percent methanol with flexible-fuel vehicles running on a blend of the two fuels.
- (3) Methanol has a high octane rating which assists gasoline (spark

ignition) engine performance.

- (4) Methanol is biodegradable and readily assimilates with water.
- (5) Methanol burns smokeless.
- (6) Methanol is a domestically produced energy source.

b. Disadvantages:

- (1) Methanol is corrosive, particularly to aluminum; engines and fuel systems specially designed to handle it use different materials, such as stainless steel.
- (2) Methanol has less than half the power per equivalent gallon (BTU value) as diesel fuel. For an equivalent range, this requires storage tanks twice the size of diesel tanks.
- (3) Methanol is quite toxic. Direct exposure to the human body has the potential of causing blindness and kidney failure. Since it is tasteless and colorless, it cannot easily be detected should it get into a water supply.
- (4) Methanol combustion generates high amounts of formaldehyde, a potential cancer causing substance. This can be offset with exhaust after-treatment, such as special catalytic converters.
- (5) In its pure state, methanol burns with a colorless flame, so a fire is hard to see. It is less volatile than gasoline but has a relatively low flash point of 54 degrees Fahrenheit.
- (6) The distribution system and infrastructure for methanol fueling are considerably less widespread than for gasoline and diesel.
- (7) Methanol has a low cetane rating, which inhibits diesel engine performance. It is not suitable for blending with diesel fuel.
- (8) Methanol has been proven to be unsafe when operating in certain ambient temperature ranges.

2. Ethanol

Ethanol is a distilled agricultural alcohol product that is a liquid and is colorless at normal ambient temperatures. Corn is the current primary grain source. It has many of the same characteristics as methanol. Currently, ethanol is used primarily in a mixture with gasoline, usually no more than 10% ethanol.

a. Advantages:

- (1) Ethanol emissions are quite low in particulates and NOx.
- (2) Like methanol, ethanol readily mixes with gasoline.

- (3) Ethanol is biodegradable and readily assimilates with water.
- (4) Ethanol is less corrosive and less toxic than methanol.
- (5) Ethanol is a domestically produced energy source.

b. Disadvantages:

- (1) The production process is extensive and the steps involved (i.e., planting, fertilizing, harvesting, shipping and processing) consume nearly as much energy as is created by the fuel.
- (2) The energy output of ethanol, though higher than methanol, is still only about half that of diesel fuel; thus, the range of ethanol-powered vehicles is limited for a given fuel storage capacity.
- (3) Ethanol emissions have some visible smoke.
- (4) Ethanol produces formaldehyde, however, this can be offset with an exhaust after-treatment.
- (5) The distribution system and infrastructure for ethanol fueling are considerably less widespread than for gasoline and diesel.

3. Clean diesel

Clean diesel was one of the alternative fuels approved in the Clean Air Act Amendments of 1990. The first step to be undertaken was further refining to reduce sulfur content and hence the significant particulate emissions caused by the sulfur. Significant advancement in this process has resulted in the development of ultra-low sulfur content diesel fuel. Refinery techniques can now produce diesel fuel with a sulfur content below 15 parts per million (PPM). The availability of this fuel supports the installation of an advanced exhaust after-treatment device in the form of a continuously regenerating trap (CRT). This CRT technology reduces the exhaust particulate content by approximately 90 percent from currently mandated levels (to point .005 grams/hp-hr) and the hydrocarbons to an unmeasurable level (to essentially zero). Further steps are being developed to add cetane boosters, which increase efficient combustion.

a. Advantages:

- (1) The additional processing costs are small, so clean and ultra-low sulfur diesels are cost-effective relative to other alternative fuels.
- (2) All existing diesel engines currently in service can use clean or ultra-low sulfur diesel without modification.
- (3) The present systems for distribution of diesel fuel are unchanged and are fully usable with clean diesel.
- (4) Clean and ultra-low sulfur diesel retains the low level of diesel fuel volatility. This makes it safer than many other alternatives.
- (5) Clean and ultra-low sulfur diesel has a higher BTU value per gallon or equivalent gallon than any other alternative fuel, and thus provides more engine efficiency, as well as more vehicle range.

(6) Ultra-low sulfur diesel offers significant reductions in emissions.

b. Disadvantages:

(1) Clean diesel is still relatively high in particulates and NOx.

(2) Clean and ultra-low sulfur diesel are fossil fuels and, as such, still leave the country dependent on foreign sources.

(3) When operating under cold conditions, starting is a problem, as with all diesel fuels.

(4) Ultra-low sulfur diesel is not readily available in most areas of the country.

4. Reformulated gasoline

Reformulated gasoline is specially blended fuel with the following properties: (1) lower vapor pressure that reduces evaporation during operation and refueling, and (2) more efficient combustion through the addition of high-octane oxygenates. Reformulated gasoline aromatic levels have been lowered, which provides less in the way of hydrocarbon tail pipe emissions.

a. Advantages:

(1) Reformulated gasoline is compatible with all existing gasoline engines.

(2) The existing fuel-delivery infrastructure is unchanged by this change in fuel properties.

(3) Reformulated gasoline is a cost-effective alternative in spite of some additional refining costs.

b. Disadvantages:

(1) Currently there is insufficient oxygenate production and storage (as well as transportation) to provide the oxygenate when and where it is needed.

(2) Like regular gasoline, reformulated gasoline has a lower caloric (BTU) value than diesel and, thus, provides less engine efficiency than diesel and less range for a given fuel capacity.

(3) Reformulated gasoline is a fossil fuel and, as such, still leaves the country dependent on foreign sources.

(4) Present technology and federal emissions and energy standards will allow reformulated gasoline to be viable to the year 2000. Significant improvements must take place if reformulated gasoline is to be used after that time, assuming present planned regulations remain in place.

B. Gaseous alternative fuels

1. Natural gas

Natural gas is primarily methane as it comes from the well, and it burns quite cleanly in its unprocessed state. Natural gas has a higher ignition point (temperature) and a narrower fuel/oxygen mixture combustion range than other fuels. Energy is consumed in processing natural gas to achieve sufficient vehicle storage (i.e., compression or cryogenic processes). (See compressed natural gas and liquid natural gas below.)

2. Compressed natural gas (CNG)

CNG consists primarily of mixtures of hydrocarbon gases and vapors, principally methane (CH₄) in a gaseous form, which is compressed for use as a vehicular fuel.

a. Advantages:

- (1) Natural gas is readily available as a domestic energy source, is inexpensive and has generally developed lower emissions than most other alternative fuels.
- (2) CNG already is in use as a viable alternative for light-duty vehicles. The American Gas Association reports over 700,000 natural gas-powered vehicles in operation in 38 countries.
- (3) Cleaner burning minimizes carbon buildup, thus increasing oil change intervals and reducing maintenance.

b. Disadvantages:

- (1) The pressure of CNG requires heavy storage tanks. The tanks are large even for short-range use. These two factors reduce cargo capacity. Maintaining reasonable cargo capacity restricts tank size and limits range. Lower caloric (BTU) value per equivalent gallon than diesel also limits engine efficiency and vehicle range.
- (2) The high pressure which the CNG fuel storage system must endure requires careful design and location on the vehicle, protection from damage, plus periodic maintenance and upkeep. Periodic tank testing for structural safety is required, and tank replacement during the life cycle of the vehicle may be necessary.
- (3) Refueling time is dependent on the type of fueling system used and can be quite lengthy. There are two methods: (1) "slow-fill," which takes from five to eight hours and is typically called "overnight" or "time-fill" refueling, and (2) "fast-fill," which takes about five to 10 minutes and requires high-volume compression and special filling apparatus.
- (4) Natural gas compression and refueling equipment is expensive and must be maintained. Fast-fill capability requires an additional "cascade" of high volume storage cylinders, which adds considerable expense to the fueling station.

- (5) There are composition variations in natural gas and the percentage of methane content from one area to another. Additional processing is required to get uniform natural gas available in all areas.
- (6) Natural gas has poor lubricative properties.

3. Liquid natural gas (LNG)

LNG utilizes the same natural gas source (primarily methane) as CNG, but requires purification of the gas and cooling and storage below -260 degrees Fahrenheit to liquefy the natural gas. Converting natural gas to liquid form provides storage of a much greater amount on the vehicle than can be achieved in the gaseous state.

a. Advantages:

- (1) LNG has all of the combustion advantages of CNG, is readily available, clean burning and generally produces lower emissions than alternatives other than CNG.
- (2) An engine will operate just as easily on LNG as it does on CNG. Though one is stored by compression and the other by cryogenics, when either gets to the point of combustion, it is natural gas.
- (3) The range of an LNG is greater than that of a CNG vehicle due to the fuel density.
- (4) The LNG fuel system pressure is less than 100 psig as compared to 3000 psig in a CNG system.
- (5) LNG provides almost pure methane with known performance characteristics.

b. Disadvantages:

- (1) Maintaining the super-cool temperature requires large, heavy, highly insulated tanks which forces a compromise between vehicle range and cargo carried.
- (2) Equipment to super-cool and liquefy gas is expensive to purchase, operate, and maintain.
- (3) LNG can be kept in the insulated storage tank for seven to 10 days. After that, it must be bled off to maintain the cold temperature required to hold the gas in liquid form.
- (4) The bleeding-off process releases hydrocarbons which, in turn, requires treatment to avoid direct release into the atmosphere.
- (5) Natural gas has poor lubricative properties.

4. Propane (also known as liquefied petroleum gas or LPG)

Propane, or LPG, is sometimes available directly from wells, but is normally produced as a by-product of the gasoline refining process. It has been used for a number of years in light-duty commercial vehicles in urban areas around the world.

a. Advantages:

- (1) Propane burns relatively clean. It emits less NO_x and contains less particulate matter than diesel, and emits less carbon monoxide and fewer hydrocarbons than gasoline.
- (2) The cleaner burning minimizes carbon buildup in the engine, resulting in less maintenance.
- (3) Propane starts better in cold weather than either diesel or gasoline.
- (4) The infrastructure for distribution and storage of propane is relatively widespread.

b. Disadvantages:

- (1) As with CNG, propane requires large and heavy fuel tanks to achieve reasonable driving range, due to reduced engine efficiency per equivalent gallon.
- (2) Propane requires the use of relatively low compression ratios, resulting in lower fuel economy.
- (3) Propane vapors, like gasoline, are heavier than air and are volatile. These explosive mixtures settle in service pits or other spots, therefore, indoor storage can be a safety concern.
- (4) As a by-product, propane is dependent on the gasoline process which limits supply. Further, it does little toward the reduction of dependency on foreign oil.
- (5) Propane has poor lubricative properties.

5. Electric power

The use of electricity as a power source for school buses is an emerging technology that is under considerable research due to the potential for reduced overall emissions. Research is centering on ways to increase the capacity and reduce the weight of batteries, as well as improving the motors used to power the vehicles and the associated electronics. Recharging technology is also developing rapidly. Most of these efforts have the goals of improving the range and performance of electric vehicles, reducing their cost and addressing operational concerns, such as recharging.

a. Advantages:

- (1) Electric-powered vehicles produce no tail pipe emissions.

- (2) The electricity distribution system is currently available since power lines are already in place.
- (3) Electricity can be, and often is, produced from renewable, domestic energy sources.
- (4) Electric-powered vehicles are extremely quiet, due to the lack of internal combustion engines.
- (5) Electric school buses can be produced as hybrid vehicles, which would have a small internal combustion engine to recharge batteries, or to supply heating systems or various other chassis accessories.
- (6) The cost per mile to operate electric-powered vehicles is low. In other words, power source maintenance is practically nil, compared to internal combustion engines.

b. Disadvantages:

- (1) Electric-powered vehicles have a low range due to battery weight and limited electrical storage capacity of current batteries.
- (2) Electric-powered vehicles may not eliminate overall emissions and/or foreign oil dependency if electricity to charge vehicle batteries is produced from coal or oil.
- (3) Current cost of electric power systems for vehicles, including batteries, is extremely high.
- (4) Battery disposal is an environmental concern.
- (5) Significant weight of current batteries limits passenger-carrying capacity.

OPERATIONS

OPERATIONS

OPERATIONS

INTRODUCTION

The success of any school transportation operation depends largely on the performance and degree of dedication displayed by those involved. These recommendations are designed to assist state agencies, school administrators and private operators in understanding their pupil transportation programs and developing applicable policies, including those for transporting students with special needs.

SCHOOL BUS USE

On July 6, 1999, the National Transportation Safety Board (NTSB) transmitted a Safety Recommendation letter to the Steering Committee of the 13th National Conference on School Transportation containing the findings and recommendation of the Special Investigation Report-Pupil Transportation in Vehicles Not Meeting Federal School Bus Standards (NTSB/SIR-99/02). This special investigation was based on the NTSB's finding in four accidents involving "nonconforming buses" that a number of children were ejected and fatally injured in three 15-passenger vans and a 25-passenger specialty bus that "did not and were not required to meet Federal school bus occupant crash protection standards." Recommendation H-99-25, issued in the letter to the National Conference on School Transportation and a number of other national associations and churches, states, "Inform their members about the circumstances of the accidents discussed in this special investigation report and urge that they use school buses or buses having equivalent occupant protection to school buses to transport children."

To assure the highest level of safety for children, consistent with the NTSB's recommendation, all students transported to and from public and private schools and school activities shall be transported in school buses as defined in Title 49, CFR Part 571 or vehicles having passenger crash protection equivalent to school buses.

STATE ADMINISTRATION

- A. The state agency(ies) responsible for pupil transportation should provide the following:
 1. Leadership in the development of a comprehensive pupil transportation program for state-wide application.
 2. A State Director of Pupil Transportation with the staff and other resources necessary for optimal job performance.
 3. Clear, concise pupil transportation policies.
 4. A cost accounting system for all expenditures in the area of pupil transportation.
 5. A state-wide management information system to accommodate pupil transportation data (e.g., costs, information gleaned from the uniform school bus crash reporting criteria, manpower availability, etc).
 6. Promotion of a pupil transportation safety program utilizing community and school district resources, school bus contractors, school transportation associations, legislation, media, law enforcement and state agencies concerned with pupil transportation.
 7. A manual or handbook for local pupil transportation supervisors, school administrators

and private contractors containing detailed instructions for implementing the state's pupil transportation laws, regulations and policies.

8. A manual or handbook for each school bus driver and each bus attendant containing the state pupil transportation regulations and recommended safety practices.
9. A comprehensive series of training programs that covers all aspects of pupil transportation, including but not limited to:
 - a. A school bus driver program for both pre-service and in-service instruction, including documentation of successful completion of classroom and behind-the-wheel instruction.
 - b. Workshops, seminars and/or conferences for all pupil transportation personnel.
 - c. Encouragement for state institutions of higher learning to provide undergraduate and graduate courses acceptable for certification purposes in pupil transportation, operation and safety.
 - d. Safety and ridership curricula for pupil passengers.
10. A manual or handbook for school bus maintenance personnel, technical issues and administrative issues to include appropriate school bus preventive maintenance procedures and on-going maintenance programs.
11. Regular visits to local school systems to evaluate transportation systems and provide necessary direction.
12. Bus and equipment standards that ensure safe and efficient student transportation.
13. Coordination with other agencies having responsibility for pupil transportation services and use of the uniform school bus crash reporting criteria.
14. Adequate funding necessary to comply with mandates adopted and approved by state legislatures and the Federal Government.

B. State Pupil Transportation Director

1. The state pupil transportation director's specific duties may include, but are not limited to:
 - a. Assisting in the implementation, interpretation and understanding of pupil transportation laws, regulations and policies.
 - b. Managing the state's pupil transportation program which includes planning, budgeting and forecasting requirements for the operation.
 - c. Supervising the preparation of manuals, handbooks and information for distribution to local transportation personnel and private operators.
 - d. Providing assistance and direction to local school administrators on request.

- e. Assisting in evaluation of state and local operations, including bus routes, and providing recommendations for policies and procedures.
- f. Planning, directing and participating in safety education for pupil transportation personnel.
- g. Assisting local personnel in planning and conducting pupil safety education programs.
- h. Requiring and maintaining appropriate reports and records.
- i. Assisting/consulting with groups involved in pupil transportation safety.
- j. Representing the interests of the pupil transportation industry.
- k. Working cooperatively with school transportation associations, school districts, parents and private contractors to promote school bus safety and efficiency.
- l. Developing and publishing easy-to-understand information on the hazards of using prescription drugs and over-the-counter medications when driving.

LOCAL SCHOOL DISTRICT ADMINISTRATION

- A. The local agency responsible for pupil transportation should: ensure compliance with federal and state pupil transportation laws, regulations and policies, including drug/alcohol testing programs as required in the Omnibus Transportation Employee Testing Act of 1991, and in compliance with 49 CFR, parts 40 and 382. Additionally, the local agency should:
 - 1. Participate in pupil transportation operations within its jurisdiction, including training programs for all transportation personnel, review of school bus routes, investigation and reporting of crashes and other transportation problems and evaluation of the pupil transportation system.
 - 2. Ensure that instruction in passenger safety, including student participation in emergency evacuation drills, is an integral part of the school curriculum. Instruction should comply with state requirements and/or Federal Highway Safety Guideline 17. (See Appendix E.)
 - 3. Provide supervision of loading and unloading areas at or near the school and provide ongoing evaluation of route pickup and drop-off locations for safety.
 - 4. Provide adequate supervision for pupils whose bus schedules necessitate their early arrival or late departure from school.
 - 5. Promote public understanding of, and support for, the school transportation program in general.
 - 6. Develop and implement local pupil transportation policies and regulations, including those for students with special needs.
 - 7. Provide transportation personnel the opportunity for growth in job-related activities.

8. Provide the necessary library of resources to ensure that transportation personnel have the proper tools to operate a safe and efficient program. These resources include but are not limited to:
 - a. Applicable federal, state and local laws, codes and regulations.
 - b. Applicable manuals and guidelines.
 - c. On-line connectivity for access to all internet and other resources.
 - d. Applicable trade journals and organizations' publications.

- B. The local pupil transportation director and/or private operator
 1. Local pupil transportation director and/or private operator's specific duties include, but are not limited to:
 - a. Providing assistance in planning, budgeting and forecasting for the pupil transportation system.
 - b. Assisting in school site selection and facility planning.
 - c. Providing, when appropriate, chassis, body and related equipment procurement.
 - d. Developing and implementing a plan for preventive and on-going equipment maintenance.
 - e. Recruiting, selecting, instructing and supervising personnel.
 - f. Routing and scheduling buses for safe, efficient and economical transportation service.
 - g. Assisting in the development and implementation of pupil safety education programs.
 - h. Working with administrators, teachers, transportation personnel, students, parents and various public and private agencies to improve their knowledge and the quality of the transportation system.
 - i. Investigating and reporting crashes, when applicable, using the uniform school bus crash reporting criteria.
 - j. Investigating reported problems.
 - k. Maintaining records and preparing reports, as required.
 - l. Developing and supervising an on-going evaluation plan for the pupil transportation system.
 - m. Implementing a drug/alcohol testing program in compliance with federal regulations for persons in safety-sensitive positions and Commercial Driver's License (CDL) drivers.

- n. Establishing and ensuring appropriate staffing levels.
2. The pupil transportation director and/or private operator who supervises transportation should have a basic understanding of the educational process and the corresponding role of transportation. Qualifications should include:
 - a. An undergraduate degree or equivalent experience in one or more of the following fields of study is desirable:
 - (1) Education
 - (2) Business Administration
 - (3) Management
 - (4) Transportation or a related field
 - b. The ability to manage personnel and resources.
 - c. Basic user-level computer competency with accounting and word processing software and knowledge of web-based information systems.
 - d. The ability to communicate effectively with school administrators, teachers, parents, students, bus drivers, law enforcement officials, etc.
 - e. Knowledge of state and federal regulations applicable to transportation of pupils.
 3. The school transportation director and/or private operator should receive formal instruction in pupil transportation management. This training should include classroom work and field experience.

DRIVER

- A. Procedures for selection of school bus drivers should include:
 1. An appropriate application form. (See Appendix E.)
 2. A check of each applicant's driving record. (Checks of the National Driver Register and the CDL Information System of the appropriate State Department of Motor Vehicles are considered essential in the case of an individual who is applying for a position as a school bus driver.)

(**Note:** The applicant should be told that these checks will be made before being asked to complete the application for employment. Establish criteria for rejection of those with unacceptable driving records.)
 3. A check to determine if each applicant has a record of criminal convictions, through both state and national criminal identification agencies. Establish criteria for rejecting those with unacceptable records.
 4. One or more personal interviews. (A properly conducted interview can be one of the most important of the selection procedures.)
 5. Physical examinations and drug and alcohol testing administered in accordance with local, state and federal requirements.

6. A determination of educational attainment. (A school bus driver applicant should demonstrate the ability to follow detailed, written instructions and be able to record and report data accurately.)

B. Driver's Manual/Handbook

Each employer should provide a driver's manual or handbook to each school bus driver at the time of employment. This manual should include the following subjects:

1. The state transportation laws, regulations and policies.
2. Motor vehicle rules and regulations applicable to school bus operation.
3. Vehicle operation and maintenance including pre- and post-trip inspections.
4. Procedures for the driver to perform when involved in a crash, when witnessing a crash and when involved with post-crash reporting.
5. Elements of basic first aid procedures with knowledge of universal precautions, plus any local practices and policies that may vary from, but should not conflict with, state requirements.
6. Elements of pupil management.
7. Requirements of the federal drug and alcohol testing program.
8. Local school district and employer policies.

C. In-service Training Program

Instructional program for school bus drivers:

1. Prior to transporting pupils, bus drivers should be required to complete a state-approved pre-service training program that includes classroom and behind-the-wheel training to enable safe and efficient vehicle operation.
2. A state-approved in-service program should be required.
3. Prior to transporting students with disabilities, the driver should receive appropriate training in compliance with Individuals with Disabilities Education Act (IDEA).
4. Drivers should receive drug and alcohol education as required in the Omnibus Transportation Employee Testing Act of 1991.

D. Behind-The Wheel Instruction

Behind-the-wheel instruction should be given in the same type and size bus the driver will be operating. When a driver is expected to operate more than one size and type vehicle, instruction should be related to the specific handling characteristics of each. All instruction should include:

1. Familiarization with the bus and its equipment.
2. Procedures for performing pre-trip and post-trip vehicle inspections.

3. Techniques for safe driving, including mirror use and adjustment, smooth starts and stops, shifting, turning, and backing.
4. Defensive driving skills.
5. Techniques for reference point driving.
6. Procedures for loading and unloading pupils at bus stops, including moving the bus only after all children are safely out of the danger zones and are at least 10 feet from the bus.
7. Procedures for railroad crossings as recommended in Appendix E and other specialized driving requirements for school bus operations.
8. Techniques to identify and avoid practices that result in driver-related vehicle abuse.
9. Procedures for en-route emergencies, including driving emergencies, emergency evacuations, and use of emergency equipment, as described in Appendix E.
10. Guidelines for safely running a route, including entrance to and departure from the bus garage and yard, following a route sheet and map, entrance to and departure from school zones, proper radio usage, mechanical difficulties and breakdown.
11. Procedures for fueling buses and handling/preventing fuel spills.

E. Physical/Mental Preparedness

All school bus drivers should be adequately prepared, both physically and mentally each day to perform the following duties:

1. Operating the vehicle in a safe and efficient manner.
2. Conducting thorough pre-trip and post-trip inspections of the vehicle and special equipment.
3. Ensuring the safety, welfare and orderly conduct of passengers while on the bus.
4. Handling emergency situations in accordance with generally accepted operating procedures.
5. Communicating effectively with school staff, students, parents, law enforcement officials and the motoring public.
6. Completing required reports.
7. Completing required training programs successfully.
8. Providing maximum safety for passengers during loading and unloading.
9. Wearing driver's seat belt whenever the bus is in motion.
10. Checking to ensure that all students have disembarked from the bus at the end of the route and at the bus storage location.

F. Evaluation

School bus drivers should be evaluated at regular intervals. These evaluations may include the following items:

1. Written test
2. Road performance checks
3. Evaluation interviews

BUS ATTENDANT

A. Selection Procedures

Procedures for selection of bus attendants should include the following items:

1. An appropriate application form. (See Appendix E.)
2. A check, through both state and national criminal identification agencies, to determine if the applicant has a record of criminal convictions. Establish criteria for rejecting those with unacceptable records.
3. One or more personal interviews. (A properly conducted interview can be one of the most important of the selection procedures.)
4. A determination of educational attainment. A bus attendant applicant should demonstrate the ability to follow detailed, written instructions and be able to record and report data accurately.

B. Bus attendants should receive instruction in the following areas:

1. The bus and its equipment;
2. Use of emergency exits;
3. Safe loading and unloading of pupils at their stops;
4. Pupil management training and policy training, including state and federal regulations related to the transportation of students with disabilities, consistent with those required for school bus drivers;
5. The safety, welfare and orderly conduct of passengers while on the bus;
6. Handling emergency situations in accordance with generally accepted operating procedures;
7. Effective communications with school staff, students, bus drivers, parents, law enforcement officials and the motoring public;
8. Completion of required written reports;

9. Checking to ensure that all students have disembarked from the bus at the end of the route and at the bus storage location.
- C. Bus attendant, Special Education (See Special Education Operation, driver/attendant)

MAINTENANCE AND SERVICE PERSONNEL

A. Staffing

Adequate staff should be employed to perform maintenance functions on a timely basis consistent with safe transportation practices.

B. In-service Instructional program for maintenance and service personnel:

1. The transportation system should make available to their maintenance and service personnel the necessary maintenance and service publications for the equipment serviced.
2. The transportation system should arrange at regular intervals for pre-service and in-service training for maintenance and service personnel. Maintenance personnel should be required or encouraged to attend state-sponsored or approved workshops or training institutes.
3. Training should include instruction in the following areas:
 - a. Preventive maintenance procedures;
 - b. Repair and/or installation procedures for each type of fleet vehicle and its varied equipment;
 - c. Procedures for specialized equipment;
 - d. Inspection of the vehicle and its equipment;
 - e. Recovery procedures for vehicles involved in a crash or breakdown;
 - f. Preparation of maintenance records;
 - g. Maintaining planned parts and equipment inventory;
 - h. Establishment of parts inventory control procedures;
 - i. Repair and installation of adaptive equipment;
 - j. Environmental compliance.

OPERATIONAL PROCEDURES

A. Policies and Guidelines:

The responsible state agency and the local school district should have clear and concise policies and guidelines for the operation of their pupil transportation programs. These are important for two reasons: (1) they have the effect of law when laws or regulations do not specifically address

a situation; (2) they serve as the rule book for persons charged with the administration of transportation services within the district.

Once established, these policies and guidelines become the basis for development of operating procedures. This allows decisions about operational details to be made at the administrative level rather than by the school board. These policies and guidelines should be precise and in writing and should cover the following topics:

1. A statement of philosophy;
2. A definition of the agency's goals and objectives;
3. Procedures for determining eligibility for transportation;
4. A description of all types of transportation provided;
5. The days on which service will be available;
6. School starting and closing times;
7. Administrative responsibilities related to program service;
8. Essential routing constraints, such as walking distances and age/grade of pupils for whom the district will provide transportation;
9. The extent of special transportation service;
10. A compilation of pupil rules and regulations;
11. Provisions for the use of contract transportation and/or charter buses;
12. Acceptable purchasing procedures;
13. Desired limits of insurance coverage;
14. The essentials of a crash prevention program, including the uniform school bus crash reporting criteria;
15. A system to communicate procedures between administrators and parents, and between administrators and the bus company or drivers, including student discipline procedure and compliance;
16. Emergency procedures and/or contingency plans to be followed in the event of a crash, unexpected school closing or unforeseen route change;
17. Use of special lighting and signaling equipment as indicated below:
 - a. If the bus is so equipped, use of alternately flashing amber lights to warn motorists that the bus is preparing to stop to take on or discharge passengers;
 - b. Use of alternately flashing red lights to inform motorists that the bus is stopped on the roadway to take on or discharge passengers;

- c. Operating the stop arms in conjunction with the flashing red signal lamps;
- d. Use of a white flashing strobe light (if equipped) to increase the visibility of the school bus on the roadway during adverse visibility conditions;
- e. Use of crossing control arms, where directed, to encourage children to cross properly in front of school buses;
- f. Use of outside public address systems for instructing children in crossing roadways and for informing them of potentially life-threatening situations.

18. Personnel

- a. An organization chart, identifying the flow of responsibility from the board of education to the school bus driver, should be provided.
- b. Employees should be provided with job specifications and descriptions at the time of employment.

19. Pre-service and in-service training requirements:

- a. All new school bus drivers should be provided with a minimum of 40 hours pre-service training before transporting students or should be trained to a defined and demonstrated level of performance as certified through state specified competency testing.
- b. All school bus drivers should be provided with a minimum of eight hours of in-service training annually.

20. Harassment

- a. School districts should develop written policies and procedures dealing with all forms of harassment on the school bus. Harassment is the use or tolerance of verbal or physical behavior which serves to threaten, demean, annoy or torment another person. Harassment would include unwanted activities or comments based on race, religion, gender, sexual preference, personal attributes, and others as determined in local policy.
- b. School districts should develop training programs to assist drivers in recognizing harassment and identifying appropriate interventions and reporting strategies.
- c. School districts should develop and implement guidelines for administering appropriate disciplinary actions resulting from acts of harassment.

B. Seating

- I. School buses provide the safest form of pupil transportation. An integral part of providing "safe" transportation in a school bus is that the passengers must be properly seated. From a safety perspective, a person who is either standing or improperly seated in a school bus is not afforded the benefits of the safety protection designed into the vehicle and is in increased jeopardy of injury in the event of a crash or extreme sudden driving maneuver.

Additionally, there must be sufficient space on the school bus seat for each passenger's body to be completely within the seat compartment. In the event of a crash or sudden driving maneuver, students that are not properly seated within the seat compartment may not benefit from the passenger crash protection systems built into the school bus under federal and state regulations.

In practice, school buses transport students of various sizes, typically from pre-schoolers to 12th graders. While a 39-inch seat may safely accommodate three pre-schoolers and/or primary school-aged children, it may not safely accommodate the same number of older children. Since the size of growing children varies, the number of pupils that can safely occupy a school bus seat also changes. Consequently, the "in use" capacity of a school bus varies depending on the size of the pupils transported. The use of a child safety seat for an infant or toddler, or of special equipment needed for a child with disabilities may further impact the "in-use" capacity of a school bus.

It is important to consider the size of the passengers on each school bus route when determining the "in-use" capacity of a school bus. It is recognized that at certain times--for example at the beginning of a school year--it may not be possible to know exactly how many students will arrive at school bus stops on a route. For that reason, there may be instances where overcrowding exists temporarily on some school buses. In such situations, efforts should be made to provide safe seating to all school bus passengers in a timely and efficient manner, so that during regular operations all passengers are safely seated.

Highway Safety Guideline #17, "A Pupil Transportation Safety", as issued by the National Highway Traffic Safety Administration, states:

- a. "Standing while school buses and school-charter buses are in motion should not be permitted. Routing and seating plans should be coordinated so as to eliminate passengers standing when a school bus or school-charter bus is in motion.
 - b. Due to variations in sizes of children of different ages, states and school districts should exercise judgment in deciding how many students are actually transported in a school bus or school-charter bus.
 - c. There should be no auxiliary seating accommodations, such as temporary or folding jump seats in school buses."
2. All children riding in school buses, or other buses used to transport pupils to and from school or school-related activities, should be properly and safely seated facing forward unless otherwise required by a child safety restraint system (CSRS). There should be adequate space on the seat for the child to be seated completely within the seating compartment.

C. Pupil Management

An effective pupil management program is a collaborative effort involving many groups of people in the school community. Parents, students, school bus drivers, school administrators, contract managers in districts where contract transportation is provided, law enforcement, and social service agencies must be part of the on-going process to motivate students to good behavior. It is the responsibility of the school district to ensure that a comprehensive student management program is developed so that all persons involved in the process are familiar with their responsibilities.

1. School, School District and/or Carrier Responsibilities

No public or private school, school district, county board of education, county superintendent of schools or any officer or employee of the school or board shall be responsible or in any way liable for the conduct or safety of any pupil of the school at any time when the pupil is not on school property, unless the school, board, or person has undertaken to provide transportation for the pupil to and from the school premises, has undertaken a school-sponsored activity off the premises of the school, has otherwise specifically assumed the responsibility or liability or has failed to exercise reasonable care under the circumstances.

In the event of the specific undertaking, the school, school district, board or person shall be liable or responsible for the conduct or safety of any pupil only while the pupil is or should be under the immediate and direct supervision of an employee of the school, school district or board.

In addition, no entity that provides transportation services for pupils, pursuant to a contract with a school, school district, city or county board of education, or county superintendent of schools, shall be responsible or in any way liable for the conduct or safety of any pupil of the public or private school at any time when the pupil is not under the immediate and direct supervision of an employee of the entity.

Specific responsibilities include the following:

- a. Establish the policies and procedures by which the program functions. These should include, but not be limited to, the examples in Appendix E.
- b. Establish regulations governing the behavior and safety of pupils at the bus stop and while boarding, riding and disembarking from the school bus. The rules students are expected to follow should be limited in number and should be posted in the bus and/or otherwise made available to all riders. (See Appendix E.)
- c. Institute and administer an instructional program that teaches pupils proper conduct and transportation safety procedures. (See Appendix E.)
- d. Conduct a training program for school bus drivers to ensure that all policies, procedures, regulations and their enforcement are understood.
- e. Ensure that parents receive written copies of the bus rules and regulations. Ensure that parents are informed about their responsibilities for the supervision and safety of students going to and from bus stops and while at the bus stops. Clearly establish parents' roles and obligations with respect to pupil promptness, attitude and behavior.
- f. Initiate procedures to ensure open lines of communication and cooperation among school administrators, bus company officials, state agencies and bus drivers.
- g. Train drivers in specific skills that will enable them to maintain order, safety and respect for the rights of others. These skills should include at least the following:

- (1) Specific verbal intervention techniques used to maintain order and safety;
 - (2) Communication skills that promote rapport and mutual respect, and that encourage pupil compliance.
 - h. Ensure that administrators support and enforce disciplinary procedures, policies and reasonable actions by the driver.
2. Driver Responsibilities
- a. Drivers should be familiar with and abide by all rules, policies and procedures affecting pupil transportation.
 - b. Drivers should recognize the importance of establishing rapport with parents, their supervisors, and school administrators when working to ensure proper pupil conduct.
 - c. Drivers should establish proper rapport with pupils.
 - d. Drivers should instruct pupils in proper behavior, consequences of improper behavior, general procedures and evacuation drills. (See Appendix E.)
 - e. Drivers should maintain order and safety and protect the rights of others on the school bus. They should exercise good judgment and prudence in this pursuit, using appropriate verbal intervention. This includes, but is not limited to, the following:
 - (1) Minimizing interior noise;
 - (2) Controlling passenger movement;
 - (3) Requiring an orderly entrance and exit;
 - (4) Eliminating movement or potential movement of objects;
 - (5) Requiring silence at railroad crossings;
 - (6) Prohibiting transportation of unauthorized materials;
 - f. Drivers should handle minor infractions with on-board consequences and discussions approved by the school district.
 - g. Drivers, in instances of serious or recurring misconduct, should follow school district policy pertaining to the misconduct and should submit written reports on appropriate forms to administrators or other persons designated to deal with discipline problems. (See Appendix E.)
 - h. Drivers should be aware that they represent the school system and/or the bus company and should present a positive image in dress, language and manner while on duty.
 - i. Drivers, including substitute or spare drivers, should be familiar with and be

provided with written route instructions of the assigned route that would include any existing railroad crossings and any fixed route hazard(s).

3. Pupil Responsibilities

Proper pupil behavior is important. The distraction of the driver can contribute to crashes. Pupils and parents should be made aware of and should abide by reasonable regulations to enhance safety. The consequences of unacceptable behavior should be clearly understood. The following actions will help to protect the pupil's rights and to maintain order on the bus:

- a. Pupils should be aware that they are responsible for their actions and behavior.
- b. Pupils should receive a copy of the rules and procedures and should be required to abide by them.
- c. Pupils should display respect for the rights and comfort of others.
- d. Pupils should be taught to realize that school bus transportation can be denied if they do not conduct themselves properly.
- e. Pupils should be made aware that any driver distraction is potentially hazardous to their safety.
- f. Pupils should be made aware of the dangers involved in and around the loading and unloading zone, including the dangers of loose clothing, drawstrings, clothing accessories, back-packs and other loose personal items.

4. Parent/Guardian Responsibilities

Parents, guardians and persons acting *in loco parentis* should:

- a. Understand and support district rules and policies, regulations and principles of school bus safety;
- b. Assist children in understanding safety rules and encourage them to abide by them;
- c. Recognize their own responsibilities for the actions of their children. Understanding this, parents or guardians shall be responsible and accountable for the conduct and safety of their children at all times prior to the arrival and after the departure of the school bus at a school bus stop;
- d. Support safe riding practices and reasonable discipline efforts;
- e. Teach children proper procedures for safely crossing the roadway before boarding and after leaving the bus as described in Appendix E;
- f. Support procedures for emergency evacuation as prescribed by states and school districts;
- g. Respect the rights and privileges of others;

- h. Communicate safety concerns to school administrators;
- i. Monitor bus stops, if possible;
- j. Support all efforts to improve school bus safety;
- k. Be aware of the dangers involved in and around the loading and unloading zone, including the dangers of loose clothing, drawstrings, clothing accessories, back-packs and other loose personal items.

D. School site selection and plant planning

When school sites are being selected, consideration should be given to the safety of the pupils riding school buses. School buses will be required to utilize the roads in and around the school site, plus public roadways leading into and away from the school area. High-density traffic flow near school exits and entrances should be avoided. Proper site selection and plant planning for improved school transportation is extremely important, as well as school bus driveways in the vicinity of the school. (See Appendix E.) More specifically, school officials should provide:

- 1. Separate and adequate space for school bus loading zones;
- 2. Clearly marked and controlled walkways through school bus zones;
- 3. Traffic flow and parking patterns for the public and non-bused students separate from the school bus loading zone.
- 4. A designated loading area for disabled passengers with special needs, if required;
- 5. An organized schedule of loading areas with stops clearly marked;
- 6. A loading and unloading site to eliminate the backing of transportation equipment;
- 7. Procedure for evaluating each school site plan annually;

E. Routing and Scheduling

It is necessary to procure a map of the area served by a particular school or school system in order to establish bus routes that will adequately meet the needs of pupils in a particular area. Information on the road conditions, railroad crossings and other factors that might affect the particular operation should be recorded along with the location of homes and the number of school-age children in each. ("Identification and Evaluation of School Bus Route and Hazard Marking Systems" appears in Appendix E.) Satisfactory school bus stops must be identified along streets and highways where buses can travel with the least amount of risk. The number of pupils to be transported and the distance to be traveled are primary factors in allocating equipment for a particular area. Pupils should be assigned to specific stops according to walking distances, grade level and the school attended. Consideration should be given to the distances between stops to comply with the minimum distance required to activate the red and amber lighting systems.

1. Routing Techniques

There are an infinite number of routing techniques that can be used. The following are examples:

- a. A circular route circumscribes an area by using different roads on out-going

and in-coming trips. It has the advantage of equalizing time in transit for transported pupils, since the first child on in the morning is the first child off in the evening.

- b. A shoestring route extends from the school to some terminal point in the district. If the bus is stored at the school, the same road or roads are used on the out-going and in-coming trips; consequently, children are always traveling more or less directly toward the school.
- c. A feeder route extends from a point farther out in the district to a transfer point on the main route. This method may be advisable for one or more of the following reasons:
 - (1) To limit the use of large buses to improved roads;
 - (2) To reduce travel time on the main route;
 - (3) To provide some form of transportation on roads which at times may be impassable by larger, more desirable motor vehicles;
- d. A shuttle route extends between two or more school buildings. Such routes are often required for the transfer of pupils in districts operating two or more schools.
- e. Retracing routes can eliminate the need for pupils to cross the roadway.
- f. Emergency routes should be established and utilized in all school systems when weather or road conditions dictate that it is not safe to travel on other than hard-surfaced roads. Announcements can be made by radio or other means when such routings are to be used.
- g. Computer-assisted routing and scheduling, requiring the use of a computerized database of students, streets and bus routes, is a key part of the routing operation. Student records are computerized, and downloading student names, addresses, school names and grades is a routine task. Some student information systems even incorporate bus routing information. The key is for transportation staff to have quick access to the location of students to be used in establishing bus stops.

Many routing systems, through a geographic information system (GIS) component, have optimization features that allow the system to create bus routes based on the locations of students. It is important to make sure that any computer-generated routes are analyzed by transportation staff before implementation because they will almost certainly need some level of adjustment. Computer-assisted routing can help to generate a more efficient routing system than a completely manual process. A computer system can also be of use in providing information needed to stagger bell times in order to share buses among schools.

The same information that is needed for bus routing can be very useful in school district planning. The grades and locations of students displayed in a

graphic format is invaluable to school administrators as school district lines are redrawn or new schools are opened. Accessing this information from a routing system also may provide a side benefit of involving the transportation staff in the planning process.

2. Methods of serving bus routes

- a. The "single-trip plan" involves a morning and an afternoon trip by one bus on each route. This form of service is well adapted to sparsely populated areas. It also meets the needs of schools where the instructional program requires both elementary and secondary pupils to arrive at the same time.
- b. The "double-trip plan" calls for each bus to cover two different routes in the morning and afternoon. This plan is suited to districts of relatively dense population where distances are not great. As children of all grades are carried on each trip, program adjustments in the instructional schedule are necessary to avoid idle waiting time at the school. If these adjustments can be made without sacrificing the interests of the children, the double trip may be economical by requiring fewer buses.
- c. The "multiple" or "dual-trip plan" calls for more than two trips each morning and afternoon over the same route by each bus. This arrangement is feasible only where route distances are relatively short or time differences between locations are great. High school pupils, for example, may be brought to school on the first morning trip, with elementary children arriving on the second trip. In the afternoon, the elementary children should be brought home first if it is desired that the elementary day be shorter than the high school day. Districts whose program requires a day of equal lengths for both groups may transport the high school pupils on the first trip in the morning and return them on the first trip in the afternoon.

3. Survey and stops

A survey should be conducted by the pupil transportation director for the purpose of identifying factors that might indicate the need for a route change. After the survey is completed, a time study should be made by driving over the route in the same equipment that will be used in the actual operation. The driver(s) who will operate the bus(es) over the route(s) should regard the trip as a dry run. All scheduled stops and times between stops should be indicated. This data, if accurately obtained, will permit the development of a schedule which probably will need little revision once it is placed into effect.

After the route has been established, a schedule showing individual stops should be available in the bus for the information of substitute drivers. Requests for new or additional service should be investigated thoroughly before a change is made. Stops should be established only after thorough investigation has revealed the location to be the most desirable in the area. It is considered poor practice to negotiate a U-turn on main arteries of traffic even though provisions for such turns may have been made. The projection of the rear end of the bus into inside traffic lanes from medians that are too narrow to accommodate bus length often creates traffic interference that places the lives of transported pupils in jeopardy. Stops should always be located at a distance from the crest of a hill or curve to allow motorists traveling at the posted speed to stop within the sight distance.

Additional precautions should include, but may not be limited to, the following:

- a. Determine the location and destination of all pupils to be transported.
- b. Provide the driver, attendance officer and the transportation office with the following information:
 - (1) A list of pupils on the bus(es);
 - (2) Approximate times for pick up and return of pupils;
 - (3) A map indicating routing of the bus and pupil locations;
 - (4) Identification of pupils with dormant medical problems that may require specific actions from the driver in the event the problem becomes active.
4. Provide parents or guardians of all pupils with the driver's name, bus number, pick up and return times, school closing information, school calendar, procedures to challenge routing decisions, etc.
5. Determine the advisability of utilizing computer-assisted route scheduling.
6. Plan routes that will permit optimum pupil safety, program efficiency and operational economy.

F. Driver's Daily Inspection of Equipment

The school bus driver is the key to an effective daily inspection program. It is the driver's responsibility to make a planned and systematic inspection of the bus before each route and/or trip, or to assure that the inspection has been completed properly. A recommended procedure requires both stationary and operating inspections. The following outline is not suggested as a model for use but is included as a guide for transportation personnel to use in developing a systematic inspection procedure.

Although this section identifies most items to be inspected, state CDL requirements may include additional items. All items should be inspected in the method prescribed by CDL requirements and any other applicable regulations.

- I. Stationary inspection:
 - a. Observe the bus for evidence of oil, fuel, coolant, grease or water leaks, vandalism, or damage to the vehicle.
 - b. Observe areas around the vehicle for hazards detrimental to vehicle movement.
 - c. Be familiar with the under-hood inspection and conduct the under-hood inspection if required to do so.

2. Walk-around inspection:

Before starting the inspection, place the transmission in neutral and set the parking brake, fully depress the clutch pedal in manual transmission-equipped vehicles and start the engine and inspect the bus from top to bottom and end to end. Check:

- a. Tires (under inflated, flat, excessively worn or damaged, valve stems, and caps);
- b. Wheels (loose or missing nuts, excessive corrosion, cracks or other damage, and any sign of misalignment);
- c. Fluid leaks (evidence of wetness on inner wheels and tires);
- d. Windows (for dirt, stickers or other obstructions to vision and clean, if necessary);
- e. Mirrors (clean, properly aimed and tightly adjusted);
- f. Warning systems (clean, properly working running lights, back-up lights, signals and signs, reflectors, turn signals, stop lights and warning flashers);
- g. Exhaust system (sagging exhaust pipes, short and leaky tailpipes and defective mufflers);
- h. Emergency exit seals to prevent possible entrance of dangerous carbon monoxide fumes, hinges and warning buzzer.
- i. Fuel systems, including fittings and attachments that must be inspected at quarterly intervals for leaks, wear, damage, securements or undue stress; container valves, appurtenances and connections looking for damage from accidental contact with stones, ice or other loose objects; fuel lines, looking for damaged or missing rubber grommets and bulkhead fittings; all bolts in mounting brackets, checking for proper torque on a systematic basis; all conducted in accordance with Federal Motor Carrier Safety Administration requirements and other applicable regulations;
- j. Body for sharp edges, missing or damaged panels, loose rub rails and bumper securement.

3. Inside safety check

- a. Passenger compartment, seats, frames, emergency exits and windows must be carefully checked.
- b. Inspect instruments and controls. With the engine operating, check the following:
 - (1) Vacuum or air pressure gauge or hydraulic indicator lights, which should indicate adequate capacity to operate brakes. Loss of air or hydraulic pressure or vacuum indicates a braking deficiency that must be corrected immediately. For buses equipped with electric hydraulic brakes, the driver will depress the brake pedal with the engine off to check the operation of the backup system.

- (2) The oil pressure gauge, indicating adequate pressure. The engine should be turned off in the event of inadequate pressure and reported immediately.
- (3) Warning lights:
 - (a) Oil pressure warning light, displaying a prolonged warning light, is a signal of oil pressure problems and should be reported immediately.
 - (b) Service brake warning light displayed during brake application indicates that the brake system is not operating properly.
 - (c) Alternator/Generator warning light displaying a continuous light "on" after the engine is running indicates a malfunction in the charging system.
 - (d) Ammeter and/or voltmeter indicating any continuous discharge should be reported immediately.
 - (e) Water temperature gauge or warning light indicator should always read "cool" or "warm." If it indicates "hot," the engine should be stopped immediately. The same action should be taken if the temperature warning light goes on.
 - (f) Anti-lock brake system warning light "on," indicates the brakes are still functional but the anti-lock system is not.

4. Check each of the following for proper operation, adjustments or condition:

- a. Lights and signals: turn signals, stop lights, special warning lights, emergency flashers, clearance (marker) lights, headlights, interior lights, and stop arm lights;
- b. Stop arm control;
- c. Windshield fan, defrosters and heaters;
- d. Horns;
- e. Service door and control;
- f. Mirrors: rear view, side view, convex and elliptical;
- g. Three emergency triangles;
- h. Driver's seat and restraint system;
- i. Fire extinguisher;
- j. First aid kit;
- k. Wipers/washers;

- l. Sanders, when equipped;
- m. Power lift, when equipped;
- n. Spare electrical fuses;
- o. Body fluid clean-up kit;
- p. Adaptive equipment devices;
- q. Belt cutter;
- r. Cross arm, if equipped;

G. Maintenance of equipment

1. Teamwork and written policies are essential to a well organized maintenance program.
 - a. Strong and reasonable school bus maintenance policies, including appropriate training, should be adopted and provide efficient guidelines for the transportation supervisor, maintenance personnel, and operators of the vehicles.
 - b. Such policies should include the maintenance responsibilities of each person involved and should provide for a planned preventive maintenance program.
2. Preventive maintenance is a carefully organized system of inspections at regular mileage or time intervals combined with the immediate attention to all reported defects.
 - a. Manufacturer's service manuals and warranty protection guidelines, as well as state inspection guidelines, contain valuable information for successful preventive maintenance programs. These instructions and procedures should be followed carefully for maximum efficiency and safety in fleet operation. Vehicle and component manufacturers (transmission, electrical, etc.) offer training for fleet mechanics. Those interested in efficient operation will take advantage of these training programs.
 - b. Objectives of a planned maintenance program:
 - (1) Keeping the vehicles in safe and efficient operating condition;
 - (2) Preventing road failures;
 - (3) Conserving fuel;
 - (4) Lowering the maintenance cost by reducing the need for major repairs or overhaul;
 - (5) Extending the useful life of the vehicle and its components;
 - (6) Enhancing vehicle appearance.
3. School districts or private contractors should develop a system whereby written communication would allow interchange and feedback relative to maintenance work needed

and maintenance work completed. An efficient system should include:

- a. Driver's report form to initiate needed maintenance;
- b. Mechanic certification of completed work;
- c. A method for permanently recording repairs and the maintenance history of each vehicle;
- d. Inspection by the appropriate state agency or its designee;

H. Records

1. Crash records function as the data base for statistical analysis which, in turn, provides material for crash prevention programs. In addition to the uniform school bus crash reporting criteria, additional crash records may include the following information:
 - a. A list of all pupils injured, their home addresses phone numbers, the extent of their injuries and appropriate explanations;
 - b. A list of bus occupants and witnesses including addresses, phone numbers and statements;
 - c. Extent of damage and an estimate of repair costs;
 - d. Post-crash data (i.e., disposition of litigation and/or summonses, driver deposition, net effect of personal injuries, remediation if any, assigned in-service, etc.);
 - e. A signed statement from the bus driver concerning the particulars of the crash;
 - f. Complaints, challenges and disposition of hearings, etc.
2. Federal personnel records should contain the information as required and allowed under federal and state laws, but as a minimum include the following:
 - a. W-4 for federal withholding of taxes;
 - b. Signed authorization for any other payroll deductions;
 - c. Signed forms relating to benefits;
 - d. Letters of commendation, recommendation and/or discipline;
 - e. Performance reviews;
 - f. Any information pertaining to an individual's payroll history;
 - g. Medical information. (Note: Based upon federal and state laws, it may be necessary to establish a separate medical file for each employee.)
3. US Department of Justice, Employment Eligibility Verification and I-9 forms should be maintained in a separate file or binder.

4. Driver qualification records should contain as a minimum the following items:
 - a. An application for employment;
 - b. Confirmed work history;
 - c. Driving records;
 - d. Criminal record;
 - e. Physical Examination, as required for the type of license and/or special school bus certificate held;
 - f. Copy of drug and alcohol testing information in compliance with current federal, state and/or company testing requirements;
 - g. All other items as required by federal and state laws and rules.

5. Training records should contain at a minimum the accurate information certifying attendance and satisfactory completion of all state and company required training. Details about each training activity should be documented and included. The following is a list of minimum topics:
 - a. Classroom Training
 - (1) Pre-service;
 - (2) In-service;
 - (3) Post-crash or evaluation.
 - b. Behind-the-Wheel Training
 - (1) Written documentation of each activity;
 - (2) A written assessment tool showing satisfactory completion, with rating;
 - (3) Documentation of the type of equipment used, both vehicle and safety;
 - (4) A log of the number of hours of instruction and practice driving.

6. Route records should contain:
 - a. Types of routes (urban, suburban, rural);
 - b. Route descriptions, including accurate route maps;
 - c. Route miles;
 - d. Information about the needs of special education pupils;
 - e. Information pertaining to road conditions and hazards utilizing "Identification and Evaluation of School Bus Route and Hazard Marking Systems" developed by NHTSA and NASDPTS.

7. Maintenance records should contain the following items:
 - a. Line setting tickets;
 - b. Work orders;
 - c. Preventive maintenance records;
 - d. Vehicle depreciation;
 - e. Equipment specifications;
 - f. Inspection reports.

8. Cost records should contain data in the following categories:
 - a. Vehicles;
 - b. Labor cost;
 - c. Parts cost;
 - d. Inventory cost;
 - e. Administrative costs.

I. Emergency & Rescue Procedures:

A Guideline Manual For School Bus Involvement has been developed and disseminated to each State Director of Transportation for reproduction in each state. The manual dissemination includes all police, fire, ambulance, emergency medical technician and any other entity designated to respond to a school bus crash, emergency or disaster.

This manual is a reference for each school system in developing its own specific emergency plan. Copies of the school system's plan should be carried in each bus. This plan should be developed in cooperation with the personnel in those agencies that will render service during emergencies. The school transportation director, school administrators, teachers, drivers, maintenance and service personnel, pupils and others should be instructed in the procedures to be followed in the event of the following situations:

1. A crash
 - a. How to evacuate and control pupils;
 - b. How to evaluate the need for medical assistance;
 - c. How to get help from the police, the fire department and the garage;
 - d. How to collect and record data essential to the preparation of the required crash reports and an operational plan to provide two-way communication with parents and/or guardians which is imperative;
 - e. How to prevent further crashes.

2. The sudden disability of the driver

Procedures for handling situations resulting in the fatal injury or disability of the bus driver should be established and communicated to appropriate persons. A list including the bus operator, emergency telephone numbers, a list of students assigned to the bus, and the special needs of students should be on the bus.

3. A bus breakdown

The emergency plan should cover procedures for the following events:

- a. Securing the bus;
- b. Controlling the passengers;
- c. Diagnosing the cause(s) of the bus breakdowns;
- d. Notifying school officials;
- e. Recovering the disabled school bus;
- f. Providing replacement transportation of passengers.

4. Inclement weather conditions

The emergency plan should provide procedures for determining the following events:

- a. When schools are to be closed;
- b. Who is to make such decisions;
- c. How decisions are to be relayed to parents, pupils, school officials and staff (including teachers and cafeteria manager), drivers, contractors, maintenance and service personnel, the news media and others;
- d. How to react to such natural phenomena as floods, hurricanes, tornadoes, earthquakes, tsunami, etc.

5. Other types of emergency situations

The emergency plan should include communication norms, data collection, stress reduction and cover such conditions and events as the following:

- a. Defense/disaster drills;
- b. Strikes by school staff, teachers, drivers or contractors;
- c. Road or bridge washouts and landslides that might block school bus routes;
- d. Bus hijacking;
- e. Weapons on board or at bus stops;

- f. Unauthorized boarding;
- g. Student health emergencies;
- h. Student fights.

J. Communication

It is necessary to keep those in charge of the system, bus companies, parents and pupils informed of all operational procedures. The school district must ensure that the channels of communication are set up so that information can be disseminated quickly and effectively. The school district must ensure that inquiries, requests, suggestions and recommendations are given prompt and appropriate attention and are handled efficiently. Some of the ways information can be disseminated and their purposes are listed below:

- 1. Bulletins: To explain the school district's transportation policy to school administrators, teachers, bus companies, drivers, parents, pupils and others associated with the operation and to clarify new laws and safety policies so that all persons involved know what is expected of them.
- 2. Meetings: To provide an opportunity for those associated with the school transportation program to share their views and to help build broad community support for safe transportation.
- 3. Public Press: To inform parents of policy, route, stop and schedule changes; of the safety record of the operation and positive driver achievement records.
- 4. Conferences: To discuss solutions to disciplinary problems with drivers, disruptive pupils and their parents and to review policy decisions affecting drivers, contractors, pupils and school administrators.
- 5. Letters: To inform parents of all school and state regulations, new routes, etc. and to reply to more urgent inquiries regarding pupil transportation safety, policy and procedures.
- 6. Telephone Calls: To provide quick contact between bus drivers and the school or between parents and the school in the event of urgent or emergency situations.
- 7. Radio, Television: To inform the public of procedures the schools will follow in case of severe weather conditions or other natural phenomena, new policies, laws, etc.
- 8. Formal Hearings: To be used, as required, for student suspensions from transportation, route challenges, serious complaints against drivers, etc.

K. Crash Reporting

- 1. The following data should be integrated into a state's generic traffic collision report for motor vehicle crashes, if not currently documented:
 - a. Carrier's name, school district, school bus contractor, etc.;
 - b. School bus driver's name, driver's license number, birth date, gender, driving record;

- c. School bus body make, chassis make, model year, vehicle identification number;
 - d. Engine location, forward, beneath, or behind windshield (specify);
 - e. GVWR and rated seating capacity, indicating W if bus is wheelchair equipped;
 - f. Number of passengers on the bus, excluding the driver;
 - g. Date, time, and location of the crash;
 - h. Police report number (if applicable);
 - i. Citation issued (Yes _____ No _____)?
2. School bus operators should develop a crash reporting form, including the information listed above and specifics about the crash. A sample crash reporting form, can be found in Appendix E.

EVALUATION OF THE PUPIL TRANSPORTATION SYSTEM

- A. Each school district should have a plan for evaluating its pupil transportation program. Such evaluations should enable school districts to:
- 1. Verify compliance with rules, regulations and laws;
 - 2. Audit the efficiency of program service;
 - 3. Monitor operational economy;
 - 4. Ensure the safety of the program in operation;
 - 5. Improve the quality of service;
 - 6. To verify pupil knowledge of school bus rules and procedures.
- B. Major types of evaluations include the following:
- 1. Informal reviews by district personnel;
 - 2. Formal evaluations by:
 - a. A private consultant;
 - b. A state agency;
 - 3. Periodic evaluations:
 - a. Monthly
 - b. Annually
 - c. Biennially

- C. Areas subject to evaluation include:
1. Board of Education policies;
 2. Routing procedures;
 3. Types of service provided;
 4. Financial obligations;
 5. Quality of service;
 6. Training of staff;
 7. Maintenance of the buses and equipment.

TRANSPORTATION OTHER THAN TO AND FROM SCHOOL

A. School-Related Activity Operations

Each school system providing activity bus operations should have comprehensive policies and guidelines which delegate responsibility for this function to the supervisor of pupil transportation. To provide safe and efficient activity transportation, lines of responsibility and authority need to be defined and personnel involved must have an understanding of their respective responsibilities.

In the interest of providing the safest means of transportation available, students should be transported to school-sponsored activities in school buses that meet state and federal standards.

These school-related activity trips may include field trips that are extensions of the instructional program, athletic trips, vocational and/or trade training, volunteer activities and recreational outings such as dances, picnics and overnight camping trips. These trips range from a few miles to those extending over several days and covering large distances.

The following items need to be considered when developing criteria for activity trip transportation:

1. Policies and guidelines including:
 - a. purpose of trip (instructional, athletic, pupil/spectator's recreation, etc.);
 - b. funding source (district or individual school funds, individual charge, parent group, etc.); and
 - c. administrative approval: The person who has authority to approve the trip.
2. A priority guideline should be developed for trip scheduling if all requests cannot be accommodated.
 - a. Advance notification should allow adequate time for the approval process and for making driver and vehicle arrangements.

- b. Methods of travel may include district-owned or contracted bus, commercial carrier or local transit equipment, air, boat, rail or combination of the above, private or school passenger automobile, when required by special or unique needs.
 - c. A trip request form should include all necessary information from trip arrangements, payroll, reimbursement and other local needs. (See Appendix E.)
 - d. An adult chaperone should be required on all activity trips. Responsibilities include passenger control, with driver having final authority.
 - e. Discipline and emergency medical procedures should require a trip release to be signed by parents and should include procedures concerning difficult or severe behavioral and medical problems and emergency policies.
3. Communication is essential. Drivers, pupils, chaperones and parents should be made aware of applicable rules and regulations. Parents should have destination information, mode of transportation, names of chaperones, departure and return times, appropriate dress and what the pupils should bring with them. A signed note from the parent or guardian is important. A detailed itinerary for all persons involved may be advisable. Identification of special medical problems in the event of an emergency en-route is necessary.
- a. Luggage accommodations, if applicable, must be included. A procedure for transporting luggage or equipment prohibited in the passenger compartment by state law and/or local regulations is necessary. Loose luggage or equipment which could cause injury or block passageways should never be transported in the passenger compartment.
 - b. Policies should detail whether or not out-of-state trips are permitted and, if so, any applicable restrictions. Regulations for states to be visited should be reviewed prior to the trip.
 - c. Insurance policies should be reviewed or agents contacted to determine adequacy of coverage. This is an absolute necessity for trips scheduled to another state or country. If vehicles other than district-owned are used, the Board of Education should determine the minimum insurance coverage to be carried. A current copy of the contract or commercial carrier's insurance should be on file with the school district.
 - d. Road and weather checks should be made by the designated person. School transportation personnel from other districts, state patrols, highway divisions and auto clubs are generally cooperative in supplying road information. If warranted, the weather bureau should also be contacted. A planned route and any contingent route for trips should be determined prior to initiation of the trip.
 - e. Contingency plans require policies and procedures that detail who has authority to make decisions if the unexpected happens during a trip. Impassable roads, crashes or mechanical breakdowns are examples. Drivers and chaperones should have access to that authority's phone number. It is also advisable to obtain phone numbers of transportation personnel in various communities

and school districts where activity vehicles regularly travel. Provisions should include plans for staying overnight if conditions do not permit a safe trip home. It is advisable to develop a mutual aid directory for contact within athletic league boundaries which could provide assistance in the event of mechanical emergencies. Drivers should be trained in procedures and regulations relating to trip crashes.

- f. Driving hours should be regulated. School districts should have regulations based on a common sense application of the Federal Motor Carrier Safety Regulation 49 CFR 395.3: 15 hours on duty of which no more than 10 hours are driving time; 8 hours continuous off-duty prior to a long trip; no more than 60 hours driving in a week.
- g. Driver selection and assignment criteria are necessary to avoid conflict and confusion. The criteria should include a driver's knowledge, skill, experience and familiarity with activity trip vehicles. The area to be traveled should also be a consideration. Drivers should be notified at least three days in advance of the trip date. Drivers who drive only activity trips occasionally should be periodically tested for driving ability and vehicle familiarity. They should hold the same license and certification as regular school bus drivers.
- h. Passenger manifest, including a list of all students and passengers being transported, should be kept by the driver and left with proper authorities at the school or institution.
- i. Evacuation instruction, including an emergency evacuation drill, or at least verbal instructions, should be given by the driver before each trip. (See Appendix E.)

4. Vehicle and equipment:

- a. The following should be taken into consideration when selecting trip vehicles:
 - (1) Miles to be traveled;
 - (2) Terrain and climate conditions;
 - (3) Number and age group of pupils;
 - (4) Luggage and equipment requirements;
 - (5) Driver familiarity with the vehicle and route;
 - (6) Federal Motor Carrier Safety Standards, if contract operated and crossing state lines.
- b. Consideration should be given for specialized equipment, or other items needed, such as:
 - (1) Luggage storage;
 - (2) Chains or sanders (Chains should be prefitted prior to trip);

- (3) Extra heaters;
 - (4) Public address system;
 - (5) Radio (am/fm, tape deck, two-way) or cellular telephone;
 - (6) Tires including off-road tread or recaps on the rear axle (recaps on front axle are prohibited);
 - (7) Spare tire;
 - (8) A tool kit containing items such as a flashlight, pliers, screwdrivers, de-icer, extra chain tighteners, etc. and additional equipment for an extended trip, as may be recommended by transportation personal at the destination.
 - (9) Cash for telephone, fuel, bridge tolls, parking fees and personal needs.
- c. Inspection requirements should be the same as for regular route buses and a detailed check should be made prior to activity trips.

5. Training

- a. Specialized training should be provided for activity trip drivers. Training should include, but not be limited to, the following:
- (1) State laws and applicable policies and rules;
 - (2) Familiarity with the activity trip vehicle and its components;
 - (3) Familiarity with specialized equipment and how to use it;
 - (4) Familiarity with local and state trip requirements;
 - (5) Route familiarization, which might include a dry run prior to the trip date, especially if extreme conditions, terrain or road difficulties may be encountered;
 - (6) Discipline procedures on trips;
 - (7) Driving under adverse conditions (night driving, slippery roads or unfamiliar mountainous driving);
 - (8) Maps, destination locations and parking areas;
 - (9) Parking location if other than the pupil destination;
 - (10) Provisions for bus security at the destination.

B. Non-School Related Activity Operations

1. Introduction

This sub-section is intended to address the various uses of a yellow school bus for operations other than to and from school and school-related activities.

2. Use, Procedures, and Policies

a. The school bus operator, in accordance with state regulations and/or laws governing school bus use, should establish procedures whereby school buses can be scheduled for non-routine use. Such scheduling should not conflict with, or be given priority over, the regular class-related demands for school buses by the school system.

b. The school system, as part of local government or in cooperation with transportation contractors, may utilize buses during times of community emergency or crisis, when demand for other public vehicles, such as trains and transit buses, is so great as to exceed available supply.

3. Legal Requirements

a. School buses operating on public roads and crossing state and national boundaries must adhere to the rules of the road in the jurisdictions in which they are operating.

b. All permits and fees need to be procured in accordance with applicable state and local laws before the trip is undertaken.

4. Operational requirements

a. Vehicle equipment used for activities must be in good working order, well-maintained, and otherwise capable of withstanding the demands of the trip.

b. All school buses and drivers operating under this section (Section IX) should comply with all state and federal requirements including Federal Motor Carrier Safety Regulations applicable to inter- and intra-state passenger transportation.

c. Aisles and exits must be kept clear and free of blockages at all times.

**SPECIAL NEEDS
STUDENT
TRANSPORTATION**

SPECIAL NEEDS
STUDENT
TRANSPORTATION

SPECIAL NEEDS STUDENT TRANSPORTATION

The purpose of this section is to recommend standard policies, procedures and guidelines for persons entrusted with the responsibility of managing transportation for students with disabilities. The term "*special education*" means "specially designed instruction to meet the unique needs of a child with a disability." Transportation is one of the "related services" required when necessary to provide such instruction.

The guidelines, policies and procedures recommended, though general in nature, do contain adequate information to guide those persons responsible for pupil transportation in developing an action plan for the safe delivery of transportation services for students with disabilities.

This section reviews the current laws governing special transportation related to the individualized education program process, recommended staff training and policy development.

The transportation administrator and pertinent staff shall become familiar with the following laws, guidelines, policies and procedures:

LAWS AFFECTING TRANSPORTATION FOR STUDENTS WITH DISABILITIES

A. Laws

1. Section 504 of P.L. 93-112, a part of the Rehabilitation Act of 1973, states in part:

"No otherwise qualified disabled individual in the United States shall, solely by reason of his handicap, be excluded from participating in, be denied the benefits of, or be subjected to discrimination under any program or activity receiving federal financial assistance." In general terms, Section 504 of P.L. 93-112(1), a part of the Rehabilitation Act of 1973, "requires that all students with disabilities (regardless of age) are eligible for a free, appropriate public education." It also requires the facility, services and activities provided to the disabled be comparable with those provided to the non-disabled, and that students with disabilities must have an equal opportunity for participation in any nonacademic and extracurricular services and activities provided by a school district. It is possible for a school district to be required to provide specialized transportation services to a student with disabilities who is not in special education.

2. "Education of the Disabled Act," P.L. 94-142, was passed by Congress in 1975, and regulations were promulgated by implementation of Part B of the Education of the Disabled Act, effective October 1, 1977. A free and appropriate public education (FAPE) is required for all students deemed disabled who are determined capable of benefiting from special education, and who meet specific age limits. While Federal law had specified ages 5 through 21, the age range changed to 3-21 with the 1990-1991 school year. Some states and court rulings require service to extend ages from birth to beyond 21 years.
3. The reauthorization of the Education of the Disabled Act changed the name to Individuals with Disabilities Education Act (IDEA). P.L. 101-476., passed in 1990. This reauthorization increased the number of related services from 13 to 17. It did not change transportation's status as a related service. The reauthorization did not change the original definitions of transportation that were listed in the Education of the Disabled Act.

Of note for transporters, the “Non-Academic Services” section, under the Free Appropriate Public Education component of IDEA requires the public agency to “provide non-academic and extracurricular services and activities in such manner necessary to afford children with disabilities an equal opportunity for participation in those services.” Obviously, one of those non-academic services is transportation. This continues the emphasis to integrate children with disabilities as much as possible with children without disabilities.

B. Characteristics:

To be disabled under IDEA, a student must have certain characteristics which adversely affect educational performance, and need special education and related services. There are thirteen categories. The disabilities are defined in the IDEA under Part B Regulations. They appear in 34 C.F.R., Part 300, Section 300.7 to 300.18, Children with Disabilities. The terms will be listed in this section as they appear in the C.F.R. The definitions can be found in Appendix F.

1. Autism
2. Deaf-Blindness
3. Hearing Impairment/Deafness
4. Mental Retardation
5. Multiple Disabilities
6. Orthopedic Impairment
7. Other Health Impairment
8. Emotional Disturbance
9. Specific Learning Disability
10. Speech and/or Language Disability
11. Traumatic Brain Injury
12. Visual Impairment/Blindness

C. Related services

As part of the mandate of a free appropriate public education, “Related services” are required when determined necessary to assist a child with a disability to benefit from special education. Transportation is a related service under IDEA, and is defined to include:

1. Travel to and from school and between schools.
2. Travel in and around school buildings.
3. Specialized equipment (such as special or adaptive buses, lifts, and ramps) if required to provide special education for a child with a disability.

INDIVIDUALIZED EDUCATION PROGRAM (IEP) - INDIVIDUALIZED FAMILY SERVICE PLAN (IFSP) PROCESS

The IDEA Amendments of 1997 state that "The State or LEA shall ensure that all of the child's special education and related services needs that have been identified through the evaluation described in paragraph (b)(1) of this section are appropriately addressed....a) Each public agency shall ensure that a full and individual evaluation is conducted for each child being considered for special education and related services under Part B of the Act:

- (1) To determine if the child is a "child with a disability" under Sec. 300.7; and
- (2) To determine the educational needs of the child.

Upon completion of an administration of tests and other evaluation materials, the determination of whether a child is a child with a disability as defined shall be made by a team of qualified professionals and the parent of a child." An evaluation team should include a teacher, psychologist, speech therapist, physical and/or occupational therapist and transportation services personnel, as needed.

The IEP Team is the formal group that designs a student's educational plan, establishes goals and objectives and determines the related services that are necessary for a student to benefit from special education. The IEP Team report most often serves as the basis for IEP Team discussions and decisions regarding a student's program content. If it is determined that a student needs transportation as a related service, and needs care or intervention exceeding that required for a non-disabled student, or needs adaptive or assistive equipment, transportation staff shall be invited to participate as a member of the IEP team.

Legal Considerations: By law, this committee must consider several issues related to the student's educational program. When transportation is considered as a related service, consideration needs to be given to the Continuum of Transportation Services available to students with disabilities, since there are a number of questions which must be addressed. All considerations are based on determining the Least Restrictive Environment (LRE) for the student. (Refer to the Continuum of Services in Appendix F.)

The Individualized Education Program: A written statement of services a student is to receive. Because the IEP can only be changed by the IEP team, written information regarding transportation as a related service should provide the necessary specificity so the driver, school, parent and student know what services to expect.

IEP Staff: While participating on an IEP Team, a transportation staff member should be particularly vigilant so as to challenge transportation requirements that would be impossible to provide (such as a maximum riding time of 30 minutes when the student lives 45 minutes from school), appears to be unsafe, or is not understood.

Discussion of Concerns: If at some point after transportation has been implemented, transportation services personnel find the transportation plans unsafe, a student's behavior changes so dramatically as to create an unsafe environment, or the transporters need more information or assistance from the special education staff, any of the personnel listed can reconvene the IEP team to discuss the concerns.

GUIDELINES

The following guidelines are intended to assist in establishing a training program for administration and school based personnel that will enable them to respond to the concerns presented by students with disabilities, which is required by IDEA, and to provide administration and school-based personnel with the skills needed to respond to routine and emergency circumstances concerning transportation.

A. School/Education Administration

School administrators and education staff who help make program decisions for students with

disabilities, including the requirement for transportation as a related service, are frequently unfamiliar with transportation capabilities and limits. Those persons should have training in areas that include the following:

1. Situations under which transportation staff would be consulted, or included in the IEP Team process.
2. State and local transportation policies and procedures, including communications and reporting procedures.
3. Transportation regulations which could assist in determining if transportation would be appropriate as a related service.
4. Alternative transportation options.
5. Current legislative, legal, and administrative decisions.
6. The application of Least Restrictive Environment (LRE) regulations to transportation placements.
7. The extent of training and skill levels available within the transportation staff.
8. The types of vehicles used for transporting students with disabilities.
9. The types of equipment and occupant securement systems used.
10. Do Not Resuscitate (DNR) policies for local school districts as well as current legislative and administrative decisions concerning this topic.

B. Transportation Administration

With increased responsibility being imposed on transportation providers through actions taken by legislative, legal and administrative authorities, those in leadership roles must involve themselves to a greater degree.

While the duties and responsibilities of transportation leadership most likely will differ between various transportation providers, there are some common areas of knowledge that are necessary to satisfactorily perform the leadership responsibilities:

1. Knowledge of federal, state and local laws and regulations regarding the equipment required on vehicles used for special education student transportation.
2. Knowledge of federal, state and local laws and regulations regarding special education staff.
3. Knowledge of operational regulations such as student pick up/drop off, including whether curb-to-school or door-to-school.
4. A general knowledge of special education transportation regulations, such as student riding time and suspension period limitations.
5. A general knowledge of due-process rights and procedures of a student with disabilities.

6. A general knowledge of the student referral, evaluation and IEP process.
7. A general knowledge of the identity of resource persons and the location and availability of appropriate training.
8. A general knowledge of vehicle staffing requirements, including when an attendant might be needed.
9. A general knowledge of the availability of emergency medical services in the community and the identity of those who could assist if such an emergency were to occur during transportation.
10. A general knowledge of state and local laws relating to child abuse and harassment reporting procedures.
11. A general knowledge of state or local laws relating to limits of liability and policies and procedures for risk management.
12. A general knowledge of federal and state rules of confidentiality.
13. A general knowledge of legislative and administrative decisions and procedures concerning DNR.

C. Drivers and Attendants

Drivers and attendants, as the direct service providers to students with disabilities with hands-on responsibility, must operate special equipment, manage student behavior and administer health care, according to their qualifications, and be knowledgeable in positioning and securing adaptive and assistive devices and the occupants who use these devices.

1. Selection and retention of transportation staff

The responsibilities frequently differ so substantially between the role of the transportation staff for non-disabled students and students with disabilities that some staff feel comfortable transporting and associating with one category of student, they prefer not to be associated with the other category of student. Thus, it is important to explain fully to applicants for special education transportation staff positions the full implications of the duties expected. By eliminating applicants who would not feel comfortable performing some required services prior to hiring, staff retention levels for this group will be relatively high. Staff retention is critical due to the considerable costs associated with the extra training required. Staff who have a continuing personal knowledge of the specific needs of individual students is a tremendous asset to their care.

2. Training components

To perform the responsibilities assigned in a safe and effective manner requires a substantial degree of specific training. Some training components which would be beneficial to transportation's staff are:

- a. Introduction to special education, including characteristics of disabling conditions, the student referral, assessment, IEP process, and protecting confidentiality of student information.

- b. Legal issues, including federal and state law, administrative rules, and local policy.
- c. Operational policies and procedures, including:
 - (1) Loading/unloading;
 - (2) Securing the bus;
 - (3) Pick up/drop off location (curb-to-curb);
 - (4) Evacuation procedures;
 - (5) Lifting procedures;
 - (6) Student accountability and observation, including evidence of neglect or abuse;
 - (7) Post-trip vehicle interior inspections for students, medicine and other articles left prior to parking vehicle;
 - (8) Reporting procedures and report writing;
 - (9) Record-keeping;
 - (10) Lines of responsibility relative to role as educational team member;
 - (11) Lines of communication, including parents and educational staff;
 - (12) Route management, including medical emergencies, no adult at home, inclement weather, field trips, etc;
 - (13) Behavior management, including:
 - (a) Techniques for the development of appropriate behavior;
 - (b) Techniques for the response management and modification of unacceptable behavior;
 - (c) Procedures for dealing with inappropriate or unacceptable student behavior that creates emergency conditions, or poses a risk to health and safety;
 - (d) Procedures for documenting and reporting inappropriate or unacceptable student behavior;
 - (e) Techniques and procedures for the response to unacceptable behavior including the possession and transportation of weapons, drugs, gang activities, harassment and/or violent behaviors;
 - (14) Blood borne pathogens and universal precaution procedures, including the use of personal protective equipment.

- (15) Policies and procedures that ensure the confidentiality of personal identifying information.

D. Special Equipment Use and Operation:

A wide variety of equipment has been identified to accommodate students with disabilities that is required to be part of the transportation vehicle's environment. It is necessary for the transportation staff to be familiar with the design and operating procedure for this special equipment, as well as knowing how to conduct equipment inspection and make simple "field adjustments" during breakdowns. Some examples are these:

1. Power lifts or ramps;
2. Emergency escape exits, including doors, windows and roof hatches;
3. Special fire suppression systems, including emergency fireblanket;
4. Power cut-off switches;
5. Emergency communications systems;
6. Climate-control;
7. Adaptive and assistive devices used to support and secure students, including mobile seating devices, child safety restraint systems, safety vests, special belts, assistive technology devices, trays and securement hardware;
8. Electronic voice communication systems which may be provided and installed by the body manufacturer, distributor, school district, operator or other party (recommended for all school buses equipped to transport passengers with special needs);
9. Service animals which can be transported to assist the student with disabilities. (District policies and procedures, as well as training, should be established prior to transport.)

E. Selecting Securement Sites on Wheelchairs

Decision-making should be a TEAM effort, not an individual's responsibility. Always consult school staff or a qualified professional if in doubt.

1. Wheelchairs should be transported in a forward-facing orientation whenever possible.
2. The manufacturer's designated securement point, if so labeled, should be used when ever possible.
3. Both front and rear tiedown sites should be just below the seat at welded sites.
4. Each strap should be at a 45-degree angle from the floor.
5. The lap belt should be at a 45-degree angle across the occupant's pelvis. When using an integrated system (in which the occupant restraint is attached to the rear tiedowns of the wheelchair securement system), the rear wheelchair securement site must be selected with this in mind.

6. A “height adjuster” may be required to achieve appropriate belt position, if the chair is small.
7. On a tilt-in-space wheelchair, the four sites must be either on the base of the wheelchair or on the seat/frame portion of the chair. For example, it is not effective to have the front hooks on the base of the chair and the rear hooks on the seat/frame portion of the chair since it would create a “teeter-totter” effect.
8. Wheelchair securement points must **not** be located on the removable parts of the wheelchair, e.g., armrests, legrests, removable wheels, etc.
9. Wheelchair securements must **not** be on the crossbar, since this allows many wheelchairs to collapse.
10. Wheelchair axles are not a first choice, and should only be used if hardened steel bolts are present. [**Note:** Many wheelchairs are equipped with removable axles that are hollow and therefore not acceptable securement sites.]
11. Some wheelchair manufacturers make an add-on bracket which can be used as an alternative tiedown site for some wheelchairs. Homemade brackets are not acceptable. Securement and restraint systems installed to secure wheelchair/mobility aids and to restrain the occupants shall be used together, and in accordance with the manufacturer’s recommendations, both to secure the wheelchair/mobility aid and to restrain the occupant. Exception to this requirement can be made only by the IEP team for individual medical or disability-related reasons.

F. Medical/Health Issues:

As a result of new regulations, which are making educational opportunities available to more students who have severe medical/health conditions, the transportation staff is finding it necessary to provide both routine and emergency health care to students during the transportation process. Additionally, transportation staff may be exposed to infectious or communicable diseases which could be debilitating, or in extreme circumstances, fatal. Training regarding medical/health issues can be divided reasonably into two categories; precautionary handling, and care and intervention.

1. Precautionary handling

All transportation staff, including drivers, attendants, mechanics, and service personnel, such as washing and cleaning staff, should be trained in universal precautions relative to the handling and exposure to contagious and communicable disease, and informed about available immunizations. Suggested topics could include the following:

- a. Characteristics of contagious and communicable diseases;
- b. Disease management techniques;
- c. Use of protective equipment and devices.

2. Care, intervention and management

Medically fragile, technology-dependent and highly disruptive students require specific care and intervention. Knowledge of basic first aid and cardiopulmonary resuscitation

provides adequate training to care for most health concerns during transportation. For those students who need additional care, management, or intervention, or present specific health risks, a care plan shall be developed during the assessment/evaluation process by the IEP Team which specifies and provides the transportation department the following information:

- a. A brief description of the student's current medical, health, or behavioral status, as well as an emergency card with information which shall include address, emergency phone numbers, etc;
- b. A description of the medical/health care or intervention necessary during transportation, including the frequency required;
- c. A description of who should provide the care or intervention;
- d. The type and extent of additional training or skills necessary for the driver and/or attendant. This may include the inspection, operation, use and care of the student's special adaptive/assistive equipment including items such as oxygen containment systems, suctioning equipment, apnea monitors, ventilation equipment, etc;
- e. A description of emergency procedures to be implemented during a medical/health crisis, including communication with medical staff;
- f. A description of the procedures to be followed in changing the care plan when conditions indicate a change is warranted;
- g. A written emergency evacuation plan which is student specific.

CONFIDENTIALITY

IDEA requires that IEP/IFSP information needed to transport a student safely, even if confidential, shall be made available to the related-service provider. Information provided to transportation staff to assist in the orderly and safe transportation of a student, including handicapping condition, medical/health issues, or other personal characteristics or information, is protected by the provisions of the Family Educational Rights and Privacy Act (FERPA), and transportation staff shall be trained regarding confidentiality requirements.

DEVELOPMENT

In education, there are many laws, rules, and regulations which dictate the service that must be provided, but few of them offer directions or suggestions as to how the service is to be provided. To guarantee a uniform and safe delivery of transportation service, and provide consistent directions to a transportation staff made up of persons with different personalities, temperament and decision-making capabilities, written local school board adopted transportation policies and procedure directives shall be required.

- A. Subjects Which Need Policy and Procedure Directives include these:
 1. Control of student medicine transported between home and school on a vehicle;
 2. Student management and discipline;
 3. Physical intervention and management;
 4. Securing the vehicle, loading, and unloading.

5. Safety vests, belts and other positioning devices;
6. Provisions for students with disabilities during early closing of school due to inclement weather or other emergencies;
7. Authority to operate special equipment (driver, attendant, parent, students, school staff or others);
8. A plan to address occasions when no adult is home to receive a student who requires assistance and/or supervision;
9. A plan to explain when to exclude special equipment which has a different design or configuration than that last used, has tears or breaks in the fabric or metal;
10. A plan to address student referrals for transportation that provides insufficient information;
11. Student pick up/drop off location (one location specified or unlimited alternative locations allowed);
12. Control and management of confidential information;
13. A plan for community emergency medical/law enforcement personnel involvement;
14. A plan describing when to use wheelchairs and mobility aids as pupil seating on school buses if the manufacturer of said device does not endorse its use as such, recognizing that in many situations the safe, economical and prudent way to transport a child is in his/her wheelchair/mobility aid;
15. District policy for Do Not Resuscitate (DNR) requests from parents, to include all appropriate school and transportation personnel. (Classroom and school bus policies may be different).
16. Driver and attendant responsibilities regarding DNR orders.

B. Policy Approval

All policies shall be in writing, and formally approved by the appropriate education authority. Procedures shall include establishing time lines for periodic reviews or revisions.

EMERGENCY EVACUATION OF STUDENTS WITH DISABILITIES

Each bus route should have a written emergency evacuation plan specific to the route and passengers. This plan should include a student's ability to evacuate or help others. When possible, students with disabilities should practice their evacuation skills as required of their non-disabled peers. The driver/attendant should also be familiar with any extra equipment on the bus which would aid in the actual evacuation, (e.g., emergency/fire blankets, belt cutters, etc.). It is important to enlist the help of school liaisons, parents and other personnel such as physical therapists, to train and help students understand emergency procedures. Local emergency personnel should also be involved in developing the plans, especially if there are unique medical complexities of the students on board.

EXTENDED SCHOOL YEAR

- A. Extended School Year (§300.309) IDEA Definition:
 - 1. The term extended school year services means special education and related services that are provided to a child with a disability:
 - a. Beyond the normal school year of the public agency;
 - b. In accordance with the child's IEP; and
 - c. At no cost to the parents of the child and meet the standards of the State Education Agency (SEA).
 - 2. Each public agency shall ensure that extended school year services are available as necessary to provide Free Appropriate Public Education (FAPE).
- B. OH Subpart C - 6
 - 1. Extended school year services must be provided only if a child's IEP team determines, on an individual basis, in accordance with the IEP provisions, that the services are necessary for the provision of FAPE to the child.
 - 2. In implementing these requirements, a public agency may not:
 - a. Limit extended school year services to particular categories of disabilities.
 - b. Unilaterally limit the type, amount, or duration of those services.



**INFANTS
TODDLERS AND
PRE-SCHOOL**

INFANTS
TODDLERS AND
PRE-SCHOOL

INFANTS, TODDLERS, AND PRE-SCHOOL CHILDREN

INTRODUCTION

Infants, toddlers and pre-school children are the youngest, most vulnerable passengers on school buses. They depend on transportation personnel to provide a safe ride to and from early intervention programs and Head Start. Transportation is a critical component for children and their families accessing services to support a child's growth and development. Transportation should be established as the mutual responsibility of parents, transportation and service providers.

Programs supported and funded by federal, state and local governments have made great strides in developing, designing and providing services for young children and their families to develop each child's full potential. The school bus, for many children, is the primary vehicle that provides access to programs and services designed to meet individual needs of children and families.

Transportation providers need to be knowledgeable and to develop skills to provide adequately for the safety of young children while being transported in school buses. Infants, toddlers and pre-school children with special physical, cognitive or behavioral needs present new challenges and responsibilities for transportation providers. These children require a great deal of supervision during the time they are in the school bus. Some issues that must be addressed to assure safe transportation in the school bus include: physical handling, communication with young children, behavior management, child safety seats, restraint systems, safety vests, wheelchairs and occupant securement systems, special equipment management, medically fragile and complex conditions, confidentiality, length of ride, personnel training and parental responsibilities.

Young children under the age of five who reside in rural, suburban and urban areas are daily passengers in school buses. Since the exact number of children under the age of five riding in school buses is unknown, uniform transportation data on this population should be collected. This population includes children served in several programs for children from birth through age five. These programs include the Early Intervention Programs for Infants and Toddlers With Disabilities (Part C), the Pre-schools Grant Program, the Early Education Program for Children with Disabilities, Head Start, Bureau of Indian Affairs Programs and Teenage Parent programs. In addition, federal programs support a number of discretionary projects that are designed to promote services for young children with disabilities and their families.

Because of the numbers of young children under the age of five who are transported on school buses, it is essential to recommend guidelines for child safety seats, occupant restraints and securement systems. The purpose of this section is to assist transportation personnel by recommending policies, procedures and guidelines, while simultaneously recognizing the need for continued testing and studies to meet the needs of young children from birth to age five who ride school buses nationwide. (Refer to Appendix G for listings of laws, and to Appendix F for characteristics of disabilities.)

ELIGIBILITY CRITERIA

Under Part 1308 *Head Start Program Performance Standards Services for Children with Disabilities*, there are descriptions of eligibility criteria used to identify a child with disabilities. The criteria are as follows:

- A. 1308.7 Eligibility Criteria: Health Impairment.
 1. A child is classified as health impaired who has limited strength, vitality or alertness due to a chronic or acute health problem which adversely affects learning.

2. The health impairment classification may include, but is not limited to, cancer, some neurological disorders, rheumatic fever, severe asthma, uncontrolled seizure disorders, heart conditions, lead poisoning, diabetes, AIDS, blood disorders (including hemophilia and sickle cell anemia), cystic fibrosis, heart disease and attention deficit disorder.
3. This category includes medically fragile children such as ventilator-dependent children who are in need of special education and related services.
4. A child may be classified as having an attention deficit disorder under this category if the child has chronic and pervasive developmentally inappropriate inattention, hyperactivity or impulsivity. To be considered a disorder, the behavior must severely affect the child's functioning. To avoid overuse of this category, grantees are cautioned to assure that only the enrolled children who most severely manifest this behavior must be classified in this category.
 - a. The condition must severely affect the performance of a child who is trying to carry out a developmentally appropriate activity that requires orienting, focusing or maintaining attention during classroom instructions and activities, planning and completing activities, following simple directions, organizing materials for play or other activities or participating in group activities. Also, it may manifest in over-activity or impulsive acts which appear to be, or are interested in, physical aggression. The disorder must manifest itself in at least two different settings, one of which must be the Head Start program site.
 - b. Children must not be classified as having attention deficit disorders based on:
 - (1) Temporary problems in attention due to events such as a divorce, death of a family member or post-traumatic stress reactions to events such as sexual abuse or violence in the neighborhood;
 - (2) Problems in attention suddenly and acutely with psychiatric disorders such as depression, anxiety and schizophrenia;
 - (3) Behaviors which may be caused by frustration stemming from inappropriate programming beyond the child's ability level or developmentally inappropriate demands for long periods of inactive, passive activity;
 - (4) Intentional noncompliance or opposition to reasonable requests that are typical of good pre-school programs; or
 - (5) Inattention due to cultural or language differences.
 - c. An attention deficit disorder must have had its onset in early childhood and must have persisted through the course of child development when children normally mature and become able to operate in a socialized pre-school environment. Because many children younger than four have difficulty orienting, maintaining, and focussing attention and are highly active, when Head Start is responsible for the evaluation, attention deficit disorder applies to four- and five-year-old children in Head Start programs, but not to three-year-olds.

- d. Assessment procedures must include teacher reports which document the frequency and nature of indications of possible attention deficit disorders and describe the specific situations and events occurring just before the problems manifested themselves. Reports must indicate how the child's functioning was impaired and must be confirmed by independent information from a second observer.

B. 1308.8 Eligibility Criteria: Emotional/Behavioral Disorders

1. An emotional/behavioral disorder is a condition in which a child's behavioral or emotional responses are so different from those of the generally accepted, age-appropriate norms of children with the same ethnic or cultural background as to result in significant impairment in social relationships, self-care, educational progress or classroom behavior. A child is classified as having an emotional/behavioral disorder who exhibits one or more of the following characteristics with such frequency, intensity or duration as to require intervention:
 - a. Seriously delayed social development, including an inability to build or maintain satisfactory (age-appropriate) interpersonal relationships with peers or adults (e.g., avoids playing with peers);
 - b. Inappropriate behavior (e.g., dangerously aggressive towards others, self-destructive, severely withdrawn, non-communicative);
 - c. A general pervasive mood of unhappiness or depression, or evidence of excessive anxiety or fears (e.g., frequent crying episodes, constant needs for reassurance); or
 - d. Has a professional diagnosis of serious emotional disturbance.
2. The eligibility decision must be based on multiple sources of data, including assessment of the child's behavior or emotional functioning in multiple settings.
3. The evaluation process must include a review of the child's regular Head Start physical examination to eliminate the possibility of misdiagnosis due to an underlying physical condition.

C. 1308.9 Eligibility Criteria: Speech or Language Impairments

1. A speech or language impairment means a communication disorder such as stuttering, impaired articulation, a language impairment, or a voice impairment, which adversely affects a child's learning.
2. A child is classified as having a speech or language impairment whose speech is unintelligible much of the time, who has been professionally diagnosed as having speech impairments which require intervention or who is professionally diagnosed as having a delay in development in his or her primary language which requires intervention.
3. A language disorder may be receptive or expressive. A language disorder may be characterized by difficulty in understanding and producing language, including word meanings (semantics), the components or words (morphology), the components of sentences (syntax) or the conventions of conversation (pragmatics).

4. A speech disorder occurs in the production of speech sounds (articulation), the loudness, pitch or quality of voice (voicing) or the rhythm of speech (fluency).
5. A child should not be classified as having a speech or language impairment whose speech or language differences may be attributed to:
 - a. Cultural, ethnic, bilingual, or dialectical differences or being non-English speaking; or
 - b. Disorders of a temporary nature due to conditions such as a dental problem; or
 - c. Delays in developing the ability to articulate only the most difficult consonants or blends of sounds within the broad general range for the child's age.

D. 1308.10 Eligibility Criteria: Mental Retardation

1. A child is classified as mentally retarded who exhibits significantly sub-average intellectual functioning and exhibits deficits in adaptive behavior which adversely affect learning. Adaptive behavior refers to age-appropriate coping with the demands of the environment through independent skills in self-care, communication and play.
2. Measurement of adaptive behavior must reflect objective documentation through the use of an established scale and appropriate behavioral/anecdotal records. An assessment of the child's functioning must also be made in settings outside the classroom.
3. Valid and reliable instruments appropriate to the age range must be used. If they do not exist for the language and cultural group to which the child belongs, observation and professional judgement are to be used instead.
4. Determination that a child is mentally retarded is never to be made on the basis of any one test alone.

E. 1308.11 Eligibility Criteria: Hearing Impairment Including Deafness

1. A child is classified as deaf if a hearing impairment exists which is so severe that the child is impaired in processing linguistic information through hearing, with or without amplification, and learning is affected. A child is classified as hard of hearing who has a permanent or fluctuating hearing impairment which adversely affects learning; or
2. The child meets the legal criteria for being hard of hearing as established by the state of residence; or
3. The child experiences recurrent temporary or fluctuating loss caused by otitis media, allergies, or eardrum perforations and other outer or middle ear anomalies over a period of three months or more. Problems associated with temporary or fluctuating hearing loss can include impaired listening skills, delayed language development, and articulation problems. Children meeting these criteria must be referred for medical care, have their hearing checked frequently, and receive speech, language or hearing services as indicated by the IEPs. As soon as special services are no longer needed, these children must no longer be classified as having a disability.

F. 1308.12 Eligibility Criteria: Orthopedic impairment

1. A child is classified as having an orthopedic impairment if the condition is severe enough to adversely affect a child's learning. An orthopedic impairment involves muscles, bones or joints and is characterized by impaired ability to maneuver in educational or non-educational settings, to perform fine or gross motor activities or to perform self-help skills and by adversely affected educational performance.
2. An orthopedic impairment includes, but is not limited to, spina bifida, cerebral palsy, loss of or deformed limbs, contracture caused by burns, arthritis or muscular dystrophy.

G. 1308.13 Eligibility Criteria: Visual Impairment Including Blindness

1. A child is classified as visually impaired when visual impairment, with correction, adversely affects a child's learning. The term includes both blind and partially seeing children. A child is visually impaired if:
 - (a) The vision loss meets the definition of legal blindness as established in the state of residence; or
 - (b) Central acuity does not exceed 20/200 in the better eye with corrective lenses, or visual acuity is greater than 20/200, but is accompanied by a limitation in the field of vision such that the widest diameter of the visual field subtends an angle no greater than 20 degrees.
2. A child is classified as having a visual impairment if the central acuity with corrective lenses is between 20/70 and 20/200 in either eye, or if visual acuity is undetermined, but there is demonstrated loss of visual function that adversely affects the learning process, including faulty muscular action, limited field of vision, cataracts, etc.

H. 1308.14 Eligibility Criteria: Learning Disabilities

1. A child is classified as having a learning disability who has a disorder in one or more of the basic psychological processes involved in understanding or in using language, spoken or written, which may manifest itself in imperfect ability to listen, think, speak or, for pre-school age children, acquire the precursor skills for reading, writing, spelling or doing mathematical calculations. The term includes such conditions as perceptual disabilities, brain injury and aphasia.
2. An evaluation team may recommend that a child be classified as having a learning disability if:
 - a. The child does not achieve commensurate with his or her age and ability levels in one or more of the areas listed in (1) above when provided with appropriate learning experiences for the age and ability; or
 - b. The child has a severe discrepancy between the achievement of developmental milestones and intellectual ability in one or more of these areas: oral expression, listening comprehension, pre-reading, pre-writing and pre-mathematics; or

c. The child shows deficits in such abilities as memory, perceptual and perceptual-motor skills, thinking, language and non-verbal activities which are not due to visual, motor, hearing or emotional disabilities, mental retardation, cultural or language factors, or lack of experiences which would help develop these skills.

3. This definition for learning disabilities applies to four- and five-year-old children in Head Start. It may be used at a program's discretion for children younger than four or when a three-year-old is referred with a professional diagnosis of learning disability. However, because of the difficulty of diagnosing learning disabilities for three-year-olds, when Head Start is responsible for the evaluation, it is not a requirement to use this category for three-year-olds.

I. 1308.15 Eligibility criteria: Autism

A child is classified as having autism when the child has a developmental disability that significantly affects verbal and non-verbal communication and social interaction, that is generally evident before age three and that adversely affects educational performance.

J. 1308.16 Eligibility Criteria: Traumatic Brain Injury

A child is classified as having traumatic brain injury whose brain injury is caused by an external physical force, or by an internal occurrence such as stroke or aneurysm, with resulting impairments that adversely affect educational performance. The term includes children with open or closed head injuries, but does not include children with brain injuries that are congenital or degenerative or caused by birth trauma.

K. 1308.17 Eligibility Criteria: Other Impairments

1. The purposes of these classification are:

- a. To further coordination with local education agencies (LEAs) and reduce problems of record keeping;
- b. To assist parents in making the transition from Head Start to other placements; and
- c. To assure that no child enrolled in Head Start is denied services which would be available to other pre-school children who are considered to have disabilities in their state.

2. If the state education agency (SEA) eligibility criteria for pre-school children include an additional category which is appropriate for a Head Start child, children meeting the criteria for that category must receive services as do children with disabilities in Head Start programs. Examples are "pre-school disabled," "in need of special education," "educationally handicapped" and "non-categorically handicapped."

3. Children ages three to five, inclusive, who are experiencing developmental delays as defined by their state and measured by appropriate diagnostic instruments and procedures in one or more of the following areas = physical development, cognitive development, communication development, social or emotional development or adaptive development, and who, by reason thereof need special education and related services, may receive services as children with disabilities in Head Start programs.

4. Children who are classified as deaf-blind whose concomitant hearing and visual impairments cause such severe communication and other developmental problems that they cannot be accommodated in special education programs solely for deaf or blind children, are eligible for services under this category.
5. Children classified as having multiple disabilities whose concomitant impairments (such as mental retardation and blindness) in combination cause such severe educational programs that they cannot be accommodated in special education programs solely for one of the impairments are eligible for services under this category. The term does not include deaf-blind children, for record-keeping purposes.

L. 1308.18 Disabilities/Health Services Coordination

1. The grantee must ensure that the disabilities coordinator and the health coordinator work closely together in the assessment process and follow up to assure that the special needs of each child with disabilities are met.
2. The grantee must ensure coordination between the disabilities coordinator and the staff person responsible for the mental health component to help teachers identify children who show signs of problems, such as possible serious depression, withdrawal, anxiety or abuse.
3. Each Head Start director or designee must supervise the administration of all medications, including prescription and over-the-counter drugs, to children with disabilities in accordance with state requirements.
4. The health coordinator, under the supervision of the Head Start director or designee, must:
 - a. Obtain the doctor's instructions and parental consent before any medication is administered;
 - b. Maintain an individual record of all medications dispensed and review the record regularly with the child's parents;
 - c. Record changes in a child's behavior which have implications for drug dosage or type and share this information with the staff, parents and the physician; and
 - d. Assure that all medications, including those required by staff and volunteers, are adequately labeled, stored under lock and key, and out of reach of children, and refrigerated, if necessary.

TRANSPORTATION SERVICES FOR INFANTS AND TODDLERS WITH DISABILITIES

The Individualized Family Service Plan (IFSP) under Part C of IDEA is the mechanism for addressing the unique needs of infants and toddlers with disabilities and their families. The IFSP process has two main parts: (1) the IFSP meeting, where parents and interagency personnel jointly make decisions about an eligible child's early intervention services; and (2) the IFSP document itself, which is a written plan for the provision of early intervention services for the child and family. The decision to provide the early intervention service transportation is made on a case-by-case basis and is directly related to the need for this service. Given the significance of the IFSP

process, there are numerous requirements concerning the IFSP document. The decision for a transportation representative to attend the IFSP meeting should be made on a case-by-case basis when a school bus is considered as the vehicle to transport an infant or toddler to and from a program location. This decision should be based on the individual needs of the child and family, as well as the service provider. The transportation representative should be a member of the IFSP team whenever the unique needs of an individual child require specialized service beyond the scope of what is traditionally provided. The involvement of transportation personnel should occur as soon as it is known that a child with a specialized need requires transportation on a school bus.

TRANSPORTATION SERVICES FOR PRE-SCHOOL CHILDREN WITH DISABILITIES

Pre-school children who ride school buses include children with and without disabilities. All pre-school children require careful planning when a school bus is selected as the mode of transportation to and from a special education or Head Start program. These two programs have significantly different requirements governing transportation. If a child is eligible for special education and the related service transportation under Part B of IDEA, the mechanism for addressing transportation services is the Individualized Education Plan (IEP).

The IEP process has two main parts: (1) the IEP meeting(s), when parents and school personnel jointly make decisions about a child's special educational program; and (2) the IEP itself, which is a written record of the decisions agreed upon at the IEP meeting. The IEP document is a written commitment and management tool for the school district.

The IEP defines resources and services to be provided to the student at no cost, and it states when and for how long these services will be provided. As such, the IEP becomes the tool to monitor compliance. The "1997 IDEA Amendments" require that a public agency provide transportation to a pre-school age child as a related service to the site at which the public agency provides special education and related services to the child, if that site is different from the site at which the child receives other pre-school or day care services.

One of the major differences between the IFSP services and IEP is that the early intervention program under Part C for infants and toddlers is a year-round program, whereas special education services under Part B represent a school-year program, unless otherwise specified by the IEP committee. The decision for transportation personnel to attend IFSP and IEP meetings should be made on a case-by-case basis.

This decision should be based on the individual needs of the child and family and the need of transportation personnel to provide this service safely. Young children require careful planning prior to initiating transportation services on school buses. The ages of these children require that the type of service required, frequency and duration of transportation be determined on a case-by-case basis. Prior to initiation of service, the following questions and concerns should be addressed:

- A. Is the child medically stable to be transported? (This decision should be made by a physician or nurse whenever the question arises.)
- B. What is the length of the ride? Does the length of ride place the child at risk based upon the child's age, development and functional level and environmental factors such as weather and temperature on the bus? (This decision should be made by the full IFSP or IEP committee.)
- C. Which physical, cognitive, communication, social-emotional and behavioral concerns should be addressed prior to initiating transportation services? (Each of these areas should be addressed by qualified personnel.)
- D. Which assistive or adaptive devices are necessary to accommodate the special needs of a child during the provision of transportation services? (This should be addressed by qualified personnel.)

- E. What type of supervision is necessary to assure safe transportation? What parent responsibilities are to be addressed on the IFSP or IEP documents? (These decisions should be made by the full IFSP or IEP Committee.)
- F. When a child is medically fragile and requires special handling, who is responsible for emergency procedures? Who is responsible for monitoring universal precautions on the school bus if it is known that a child has an infectious disease which requires special precautions? (This decision should be made by the full IFSP or IEP Committee.)
- G. If a child is provided with a private-duty non-IEP nurse, how are the services addressed on an IEP?

It is recommended that authorized transportation and special education and early intervention personnel converse prior to the IFSP or IEP team committing to special services. The mechanism for decision-making for all special services is the IFSP or IEP process for children receiving services under IDEA.

HEAD START

Head Start programs are required to provide special services for three through five year-old children with disabilities. Head Start programs are required to have a "Disabilities Coordinator" who is responsible for developing a disabilities service plan that provides for the special needs of children with disabilities and their parents. This plan must specify those services to be provided directly by Head Start and those that are provided by other agencies. Transportation is one of the related services addressed under '1308.4(o)(5).

Transportation is a related service to be provided to children with disabilities. When transportation to the program site and to special services can be accessed from other agencies, it should be used. When it is not available, program funds are to be used. Use of taxis is an allowable expense if there are no alternatives available and transportation is necessary to enable a child to be served.

GUIDELINES FOR INFANTS, TODDLERS, AND PRE-SCHOOL CHILDREN

The following guidelines are designed specifically to assist with transportation decision-making for infants, toddlers, and pre-school children.

A. Administrator's Role

The transportation supervisor (or designee) should be responsible for the supervision of transportation services for infants, toddlers, and pre-school children. It is essential that this individual be knowledgeable about the unique needs of this age group. Transportation personnel responsible for the daily transportation of young children should receive appropriate training from professionals qualified to make decisions regarding child safety, seating, communication, physical handling, health and medical needs and other special circumstances. Based on a curriculum developed by NHTSA, AAA certifies child passenger safety technicians. The child passenger safety technician training is sponsored by a variety of organizations, including law enforcement, hospitals, public health, insurance companies, etc. Each school district should have policies and procedures in place regarding the transportation of children from birth to age five. The policies and procedures should specify when it is required that the transportation supervisor or a designee attend IFSP, IEP or Head Start meetings. Transportation of children with special needs should be addressed on the IFSP or IEP when this service is provided. The transportation supervisor should be responsible for the following:

- 1. Selecting vehicles used for infants, toddlers and pre-school children;

2. Training drivers and attendants who transport infants, toddlers and pre-school children;
3. Selecting equipment and occupant securement specific to the transportation of infants, toddlers, and pre-school children;
4. Disseminating information about “parents’ responsibilities”;
5. Providing information about appropriate practices when transporting young children with special needs, including confidentiality of information;
6. Establishing emergency policies and procedures;
7. Establishing staffing requirements; and
8. Assuring that transportation decisions for a child are made on a case-by-case basis and are appropriate to meet individual needs of a child in accordance with what is recorded on a child’s IFSP or IEP.

B. Drivers

The driver must be knowledgeable about his responsibility for each child on the school bus. This includes safely operating the school bus and supervising the safety of all young passengers. These recommendations should be followed with or without the presence of a bus attendant. In addition to their regular duties, the drivers should be responsible for the following:

1. General knowledge about the development of young children, including specific disability conditions;
2. Age-appropriate physical handling, communication and behavior management of young children;
3. Appropriate use of all the equipment (e.g., power lifts, child restraint systems, safety vests, wheelchairs, securement devices/occupant restraints and safety belts);
4. Loading and unloading of children who are ambulatory or non-ambulatory;
5. Evacuation and evacuation drills;
6. Knowledge about transportation requirements on a child’s IFSP or IEP, including confidentiality;
7. Knowledge about special needs on the vehicle (e.g., apnea, asthma or other respiratory conditions, life-threatening allergies to irritants, assistive devices, communicable diseases, g-tubes, oxygen, technological dependence, tracheostomy tubes, medical devices, medically complex and fragile conditions, uncontrollable seizure disorders and “Do Not Resuscitate” orders);
8. Knowledge about child protection laws (e.g., abuse and neglect);
9. Exhibiting effective communication skills with school staff, students, parents, law enforcement officials and the motoring public.

C. Bus Attendants

The bus attendant should assume primary responsibility for the supervision and safety of passengers on the school bus during its operation. Bus attendants should be knowledgeable and well informed about infant, toddler, and pre-school child development for both children with and without special needs. Attendants should be knowledgeable about the following:

1. The cognitive, communication, physical, social-emotional, behavioral development and functional level of young children, including the unique needs of specific children in relationship to their disabilities;
2. Using age-appropriate physical handling, communication, and behavior management of young children;
3. Appropriate use of equipment on the school bus (e.g., power lifts, child safety restraint systems such as child safety seats and safety vests, related securement systems, including vest mounting and safety belts, wheelchairs and wheelchair tiedowns and occupant restraint systems);
4. Loading and unloading of children who are ambulatory or non-ambulatory;
5. Evacuation and evacuation drills;
6. Transportation requirements on the IFSP or IEP, including confidentiality;
7. Special needs on the vehicle (e.g., apnea, asthma or other respiratory conditions, life threatening allergies to irritants, assistive devices, communicable diseases, g-tubes, shunts, oxygen, technological dependence, tracheostomy tubes, medical devices, medically complex and fragile conditions, uncontrollable seizure disorders and "Do Not Resuscitate" orders);
8. Child protection laws (e.g., abuse and neglect); and
9. Communicating effectively with school staff, students, parents, law enforcement officials and the motoring public.

D. Training

It is essential that all transportation personnel responsible for infants, toddlers and pre-school children receive training, which should include the following recommendations:

1. Training should be conducted by staff knowledgeable about the needs of young children who must be transported. Staff may include child passenger safety technicians, child development specialists, representatives of manufacturers of specialized equipment, nurses, occupational therapists, physical therapists, psychologists, respiratory therapists, special educators, transportation supervisors and other personnel, depending on the unique needs of the individuals being transported.
2. Training should take place both in a classroom and on the school bus.
3. There should be a checklist for the purpose of recording specific skills that have been mastered.

4. It is essential that all first-aid training be specifically designed for the infants, toddlers, and pre-school children.
5. All personnel transporting young children should be required to have a first-aid course. On-going training should be conducted by certified personnel in their respective areas of expertise. The type of training provided should be directly related to the specific special

needs that the driver and assistant are required to provide. At a minimum, drivers and assistants should be able to operate any special equipment for which they are respon-

sible, know how to manage infants, toddlers and pre-school children, be capable of administering an IFSP- or IEP- approved health care service in accordance with state law and be trained about seating and securing adaptive and assistive devices. Comprehensive training for transportation personnel providing daily services should include the following topics to support safety and appropriate transportation services for this young population and their families:

- a. Assistive-device management;
- b. Child Safety Restraint Systems (CSRS);
- c. Communicable disease management practices;
- d. Communication (supervisors, school personnel, parents);
- e. Confidentiality;
- f. Emergencies;
- g. Emergency evacuation drills;
- h. Emergency information management requirements;
- i. Equipment;
- j. Evacuation;
- k. Federal and state regulations;
- l. First aid training;
- m. Individual Family Service Plans;
- n. Individualized Education Programs;
- o. The development of infants, toddlers, and pre-school children with developmental delays and disabilities;
- p. Loading and unloading;
- q. Medically fragile children;
- r. Medicine transport;

- s. Pickup and drop-off, including provision for when an adult is not at the scheduled drop-off;
- t. Required record-keeping;
- u. Reports;
- v. Special medical conditions;
- w. Specialized communication;
- x. Technology-dependent conditions;
- y. Universal Precautions; and
- z. Vehicle selection.

E. Equipment

Great strides have been made in the type of equipment used to assist infants, toddlers and pre-school children with special needs. These children present multiple challenges to providers of transportation. The school bus vehicle is significant because it is the mechanism for transporting young children who have special needs to and from support and development programs. To assure child passenger safety on the school bus, transportation personnel will need training to work with infants, toddlers and pre-school children who use a variety of equipment. Challenges relating to proper use and installation of CSRSs and car seats arise. Many of these challenges are addressed in NHTSA's "Guideline for the Safe Transportation of Pre-school Age Children in School Buses." (February 1999)

Infants, toddlers and pre-school children with special needs present a challenge for transportation personnel as conventional school bus seats do not accommodate body sizes of these children. This population includes children who sit upright, but require a safety belt or vest to provide upper body support and to keep the child from moving off the bus seat. Each school bus pre-school age passenger should use an occupant protection system appropriate for age, weight and height.

Note: The following standards are applicable to this section.

FMVSS No. 208	FMVSS No. 209	FMVSS No. 210
FMVSS No. 213	FMVSS No. 222	FMVSS No. 225

All CSRSs used on the school bus must:

1. Meet requirements of FMVSS No. 213;
2. Be used and installed according to the manufacturer's instructions;
3. Not be under a recall which recommends non-use of the seat;
4. Have all parts intact and in working order;
5. Be secured to a vehicle seat with a safety belt that meets FMVSS No. 209 or anchorages to meet FMVSS No. 225; and

6. Use safety belts, if required that are installed only on bus seats that meet FMVSS No. 210.

F. Child Safety Restraint Systems (CSRS)

CSRSs used on school buses must be appropriate for the individual child and must be used correctly. All of the restraint systems used for transportation must be secured to the bus seat in the manner prescribed and approved by both the school bus manufacturer and CSRS directions.

1. Elements of Correct Installation of CSRSs

It is recognized that compartmentalization, the passive safety system required on school buses under FMVSS No. 222, provides a higher level of safety to children over 40 pounds without diagnosed medical complexities or fragility than to children who might require special securement or positioning. Therefore, booster seats are not recommended for most children over 40 pounds in school buses.

- a. Direction

Position (rear-or forward-facing) and adjust recline angle accordingly.

- b. Belt Paths

Use the correct belt path on the CSRS as directed by the manufacturer's instructions.

- c. Installation

To achieve tight installation, place adult's full weight into the seat of the CSRS to compress the vehicle seat cushion. Pull the safety belt tight, buckle and lock the safety belt. The CSRS should not move more than 1 inch forward or side to side.

2. Types of Restraints

- a. Rear-facing CSRS (infant-only)

These seats are designed for infants from birth to twenty pounds (manufacturer's instructions) and one year of age, usually less than 26 inches in length.

The rear-facing position at a 45 degree recline supports the infant's head, neck and back. Harness straps must be at or below the infant's shoulders.

Harness straps must be snug (allow only one finger of space under the harness at the collar bone) and must lie flat (not twisted).

The harness retainer clip, which is designed to hold the harness straps in place, should always be placed at armpit level. Avoid any extra padding or blankets behind or beneath the infant.

- b. Convertible CSRS (Rear-Facing)

Rear-facing infant position is designed for babies from birth to twenty pounds, and one year of age (manufacturer's instructions) and usually less than 26 inches in length.

The rear-facing position at a 45 degree recline supports the infant's head, neck and back.

The harness straps must be at or below the infant's shoulders.

Harness straps must be snug (allow one finger of space under the harness at the collar bone) and lie flat (not twisted).

The harness retainer clip, which is designed to hold the harness straps in place, is always at armpit level.

Avoid any extra padding or blankets behind the infant.

Avoid the use of a T-shield or tray shield with infants.

Note: There are several CSRSs that ride rear-facing to thirty pounds to accommodate the larger infant and to comply with NHTSA's "Guide line for the Safe Transportation of Pre-school Age Children in School Buses."

c. Convertible CSRS (Forward-Facing)

Forward-facing CSRS with five-point harness, T-Shield or tray-shield are designed for children above twenty pounds to sixty pounds.

The seat should be adjusted to the upright position.

Harness straps must be in the upper slot (at or above the child's shoulders).

The seat may be used until the child's ears are above the back of the shell.

Harness straps must be snug (allow one finger of space under the harness at the collar bone) and lie flat (not twisted).

Note: There are some CSRSs that cannot be installed properly in a twenty-inch bus seat (i.e. tray-shield).

d. Car Beds

Note: A car bed for infants up to 20 pounds allows the infant to lie flat. The use of a car bed should be predicated on the advise of a physician or an appropriate medical support professional (i.e. physical/occupational therapist) and approved by qualified personnel at an IFSP team meeting.

(1) Lateral support can be added at both sides of the infant. Avoid placing padding around the infant's head to prevent airway blockage.

- (2) Beds must be secured to the bus seat, with the seat belt passing through both slide loops.
- (3) Adjust the harness system to a snug fit as specified by the manufacturer. Harness straps should lie flat (not twisted).
- (4) Caution should be given to gastrostomy-tubes tracheostomies and shunts.

e. Specialized Positioning Seats

- (1) These seats are used only when a child does not fit in a standard CSRS or has a particular condition warranting more support.
- (2) The seat may require an additional tether strap to secure the seat to a bus seat.
- (3) The safety belt must be routed through the appropriate belt path specified by the manufacturer's instructions to secure the CSRS.
- (4) If a retainer clip is used, it must be positioned at armpit level.
- (5) Caution should be given to gastrostomy-tubes tracheostomies and shunts.

f. Booster Safety Seats (Belt Positioning Boosters Only)

A booster seat should be used only if children are between 40 and 80 pounds and must be used in conjunction with a lap-shoulder belt.

g. Safety Vests

- (1) Vest selection should be appropriate for the height, weight, and waist of the child. Proper fit must account for seasonal changes in clothing.
- (2) The decision to use a vest should be made by an IFSP or IEP team that includes qualified personnel and the parent.
- (3) The use of safety vests should be noted on the IFSP or IEP.
- (4) Vests should be anchored as specified by the manufacturer.
- (5) The decision to use vests for wheelchair usage must be made by an IFSP or IEP team that includes qualified personnel and the parent and should be noted on the IFSP or IEP.
- (6) Caution should be given to gastrostomy-tubes, tracheostomies and shunts.
- (7) Children may have a tendency to slide under the vest/safety belt or submarine and should be securely fitted with a crotch strap supplied by the manufacturer.
- (8) If unrestrained students share the seat with a student in a child safety restraint, the student using the restraint should be placed in a window-seating position.

- (9) The seat behind the child in a vest should be kept empty or occupied by a child who is also in a child safety restraint system.
- (10) Portable seat mounting straps should be checked for proper fit by transportation personnel during pre-trip inspections.

h. Wheelchairs

- (1) All decisions regarding the use of wheelchairs on the school bus must be made by an IFSP or IEP team that includes qualified personnel and the parent and should be noted on the IFSP or IEP.
- (2) Appropriate positioning of a child in a wheelchair should be made by qualified personnel including IFSP or IEP committee members and should be noted on the IFSP or IEP.
- (3) The IFSP or IEP committee including qualified personnel should determine when it is appropriate to transfer a child from a wheelchair and placed on the original manufacturer's seat using age appropriate child safety seats or vest.

G. Bus Seat Designated for a Child Safety Restraint System

The transportation provider should ensure installation and use in accordance with the following NHTSA guidelines:

1. School bus seats designated for CSRSs are located starting at the front of the vehicle to provide drivers with quick access to and a clear view of the CSRS occupants.
2. CSRS anchorages on school bus seats should meet all applicable FMVSSs.
3. When ordering new school buses, the maximum spacing specified under FMVSS No. 222, School Bus Passenger Seating and Crash Protection, (within 24 inches from the seating reference point) is recommended for seats designated for CSRSs to provide adequate space for the CSRSs.
4. The combined width of CSRS and/or other passengers on a single seat does not exceed the width of the seat.
5. If other students share seats with the CSRSs, the CSRSs are placed in window-seating position.

H. Medical Equipment

All decisions regarding medical equipment in the school bus should be made in accordance with state laws and regulations. Decisions regarding medical equipment should be the joint decision of trained personnel knowledgeable about the type of medical assistance and support an infant, toddler, or pre-school child may need while on a school bus. Decisions should be made by qualified team members in attendance at IFSP or IEP meetings, including the parent. The IFSP or IEP document should include all the appropriate information. Safe transportation specifications should be documented on the IFSP or IEP. Some special considerations and recommendations are as follows:

1. All medical support equipment should be secured appropriately.
2. Latched compartments are the preferred methods of transport.
3. All medical equipment should be secured below the window.

4. Liquid oxygen should be approved by the manufacturer for transport and securely mounted and fastened to prevent damage and exposure to intense heat levels.

I. Special Considerations

Because of the dependency of young children and the need to make decisions on a case-by-case basis, the following section on special considerations is provided for guidance on a variety of issues related to the transportation of infants, toddlers and pre-school children.

1. Confidentiality

Confidentiality of information should be assured in accordance with the requirements of the Individuals with Disabilities Education Act Amendment of 1997, Part B and Part C, Head Start Regulations, and the Family Education Rights and Privacy Act Amendments of 1996.

All transportation personnel should receive annual training regarding confidentiality requirements.

2. Emergency information

All parents, guardians or persons *in loco parentis* should be requested to fill out emergency transportation cards prior to initiating services. At minimum, each emergency information card should request the following information: child's name, date of birth, program attending, height, weight, parents' names, address, (two) emergency contacts, child's doctor, hospital preferences, allergies, current medications, medical, communication and behavioral concerns, bus equipment required and special conditions. This information should be updated annually or semiannually because of the growth of infants and toddlers. The bus driver and attendant should have access to this information on the school bus to properly transport students in child safety restraint systems.

3. Equipment Maintenance

Procedures should be established for scheduled maintenance, cleaning and inspection of all equipment, including child safety restraint systems.

4. Evacuation

All school buses transporting infants, toddlers and pre-school children should have a written evacuation plan. Evacuation drills should be practiced on a scheduled basis, but no less than for school-age children. All buses should be equipped with seat belt cutters to assist in the emergency evacuation of children in child safety restraint systems and wheelchairs.

5. Accessory Adaptive Equipment

All lap boards or trays, augmentative communication devices and ambulation equipment that attach to wheelchairs should be removed and secured during the time the child is transported on the school bus. The child should board and leave the school bus with the lap board or tray off the wheelchair.

6. Medically Complex and Fragile Children

Decisions regarding the safe transportation of medically complex and fragile children should be made by qualified personnel and addressed on the child's IFSP or IEP prior to

initiating transportation services. All school buses transporting medically complex and fragile children should have personnel knowledgeable about an individual child's specific medical needs and be trained to administer first aid for young children.

7. Transporting Medications

There should be a policy and procedure for transporting medication between home and the school. In no instance should a child be allowed to transport medicine to and from the school on his person.

8. Radios/Two Way Communication

All school buses transporting infants, toddlers and pre-school children should have two-way communications and designated contact persons during the time the children are transported on the school bus.

9. Supervision

All infants, toddlers and pre-school children should be supervised on the school bus using the appropriate child staff ratios based upon individually determined needs. Additional supervisory personnel required to transport individual students should be determined on a case-by-case basis by qualified personnel. This information should be recorded on the IFSP or IEP document.

10. Seating and Safety Belt Buckles

All school buses transporting infants, toddlers and pre-school children should have a seating chart that is kept on the school bus. This is necessary in the event there is an emergency and there is a substitute driver or attendant. Decisions regarding seating should be done on an individual child basis using information known about the child's special needs. Safety belt buckles should not be mounted at the exterior wall for easier installation of a CSRS.

Note: The placement and use of CSRSs should be according to the NHTSA guidelines.

11. Technology-Dependent Children

Decisions regarding the safe transportation of technology-dependent children should be made by qualified personnel and addressed on the child's IFSP or IEP. On all school buses transporting children who are technology-dependent, there should be qualified personnel knowledgeable about an individual child's specific medical needs trained to administer first aid or to carry out procedures specified on the child's IFSP or IEP. All medical service provisions should be in accordance with federal and state laws.

12. Universal Precautions

All transportation personnel involved in direct service delivery for infants, toddlers, and pre-school children should be directly trained in universal precautions related to the physical day-to-day handling of young children and potential exposure to contagious and communicable diseases.



SCHOOL BUS INSPECTION

SCHOOL BUS
INSPECTION

SCHOOL BUS INSPECTION

HISTORY

School bus safety vehicle inspection programs vary greatly from state to state. Some states have no regulatory inspection program. In others, third-party inspections performed by regulatory agencies range from a biennial, detailed, and complete inspection by a single inspector or team to annual spot inspections of a limited number of components.

The personnel who conduct inspections have varying degrees of qualifications and experience, which range from former mechanics or police officers to administrative safety officials.

STATE INSPECTION PROGRAMS

Each responsible party is urged to establish a neutral third-party inspection program. Some states have a system of self-inspection by individual school districts or contractors. While such programs can be effective with no governmental oversight, the effectiveness of the program will likely be scrutinized more thoroughly than programs where governmental oversight exists. Personnel conducting school bus safety inspections should be knowledgeable in the mechanical components of a school bus and should be aware of all the applicable construction standards, laws, rules and all other requirements of their jurisdiction. States should also develop specific inspection regulations, rules, procedures and out-of-service criteria for all vehicles utilized for pupil transportation.

INSPECTION PROCEDURE

School bus safety inspections should consist of a standardized inspection where vehicles are placed out-of-service based on standardized criteria. Such criteria should not, under any circumstances, exceed the manufacturers' recommendation for component condition, wear level or other tolerance for a particular vehicle. The procedure for individual bus inspections will vary depending on the number of components to be checked in accordance with local rules and regulations, number of buses to be inspected, number of inspection personnel available and the type of inspection facility (whether equipped with a pit or lift or if inspections are performed on a "creeper") available.

THE CRITERIA

The purpose of these criteria is to identify critical school bus components and provide criteria that an inspector(s) can utilize to determine if a school bus is safe for pupil transportation. While it is recognized that each state may have its own list of components to be checked and tolerances for each, these criteria are intended to establish a nationwide minimum criteria for inspecting and placing school buses out of service.

All items relating to the safe operation of a school bus should be inspected, and these criteria are not intended to be used as a complete list of components to be inspected. The inspection criteria used in this document are recommended for inspections other than pre-trip, preventive maintenance or enroute. **ADDITIONALLY THESE CRITERIA ARE NOT INTENDED TO REPLACE, MODIFY OR ALTER THE VEHICLE MANUFACTURER'S RECOMMENDED PREVENTIVE MAINTENANCE (PM) SCHEDULE OR DRIVER PRE-TRIP INSPECTION.**

The inspection items are numerically coded so that, if desired, a database of the findings can easily be developed. The checklist includes the inspection item and a brief but concise description of the component or condition. If any listed component meets the defect criteria specified for that component, the school bus should not be placed in service until the component is repaired.

It is intended that these criteria will provide a working document for both the inspector and the operator's maintenance program.

School Bus Recommended Out-of-Service Criteria
SCHOOL BUS BODY/CHASSIS

ITEM NO.	INSPECTION ITEM	DEFECT	ACTION
10.00	BRAKE SYSTEM		
10.01	ADJUSTMENT	Any one brake beyond the adjustment LIMIT (see table #1)	
10.02	AIR SYSTEM	Fails to maintain pressure when: a) the leakage rate (brakes released) exceeds 2psi/min. b) the leakage rate (brakes applied) exceeds 3psi/min. c) fails to recover air pressure as recommended	
10.10	BRAKE SYSTEM (hydraulic)		
10.11	MASTER CYLINDER	a) reservoir is below minimum level b) any leak of fluid in the master cylinder unit system	
10.12	PEDAL RESERVE	Fails to maintain manufacturer designed height and travel requirements (OEM)	
10.13	POWER ASSIST UNIT	Fails to function as designed (OEM)	
10.20	BRAKE COMPONENTS		
10.21	(AIR and HYDRAULIC)		
10.22	BRAKE HOSES/TUBING	a) brake hose with any damage extending through the outer reinforcement ply b) any bulge or swelling when brakes are applied c) any restriction due to cracked, broken or crimped line/hose d) any line, tubing, hose, or connection that is not constructed to meet all applicable manufacturing codes and standards (OEM)	
10.23	BRAKE LINING	a) any lining/pad worn to the recommended replacement measurement or wear mark b) lining pad is broken, not firmly attached to shoe or plate, or is contaminated with oil or grease c) fails to make contact with drum (frozen, binding, uneven)	
10.30	PARKING BRAKE	Not present and working as designed	

ITEM NO.	INSPECTION ITEM	DEFECT	ACTION
10.40	STEERING SYSTEM	a) any modification or other condition that interferes with the free movement of any steering component b) any absence or looseness of U - bolt(s) or positioning part(s) c) worn or faulty, or obviously repair-welded universal joint(s) d) steering wheel not properly secured	
10.41	STEERING COLUMN		
10.42	FRONT AXLE BEAM	Any crack(s) or obvious welded repair	
10.43	STEERING GEAR BOX	a) any mounting bolt(s) loose or missing b) any crack(s) in gear box or mounting brackets c) any obvious welded repair	
10.44	PITMAN ARM	a) any looseness of the Pitman Arm on the steering gear output shaft b) any obvious welded repair	
10.45	POWER STEERING	a) auxiliary power assist cylinder loose b) power steering pump inoperable	
10.46	BALL and SOCKET JOINTS	a) any movement under steering load of a nut stud b) any motion, other than rotational, between any linkage member and its attachment point of more than 1/8 inch measured with hand pressure only c) any obvious welded repair	
10.47	TIE RODS and DRAG LINKS	a) loose clamp(s) or clamp bolt(s) on tie rod or drag links b) any looseness in any threaded joint	
10.48	NUTS	Loose or missing fasteners on tie rod, Pitman Arm, drag link, steering arm or tie rod arm	
10.49	HOSES AND FLUIDS	Any faulty fluid control device, leak, or empty reservoir	

ITEM NO.	INSPECTION ITEM	DEFECT	ACTION
10.50	SUSPENSION COMPONENTS		
10.51	AXLE PARTS/MEMBERS	<ul style="list-style-type: none"> a) any U-bolt or other spring to axle clamp bolt(s) cracked, broken, loose, or missing b) any spring hanger(s), or other axle positioning parts cracked, broken, loose, or missing that results in shifting of an axle from its normal position c) any worn (beyond manufacturer's specifications) or improperly assembled U bolt, shock, king pin, ball joint, strut, air bag and positioning component (OEM) d) any spring hanger, assembly part or leaf, broken or missing e) coil spring broken 	
10.60	CHASSIS/FRAME/ UNIBODY		
10.61	FRAME	<ul style="list-style-type: none"> a) any cracked, loose, sagging or broken frame siderail b) any obvious bend or damage resulting from a collision c) any worn or loose mounting hole 	
10.62	CROSS MEMBERS	Any cross member, outrigger or other structural support cracked, missing or deformed	
10.63	OUTRIGGERS/ BODY SUPPORT	Any missing, broken, shifted or corroded part that would affect the safe operation of the vehicle	
10.64	BUMPERS	Any bumper missing or not secured	
10.70	EXHAUST SYSTEM		
10.71	LEAKS	Any part of the exhaust system that has a measurable leak (audible or felt) or discharges under the passenger or engine compartment	
10.80	FUEL SYSTEM		
10.81	FUEL CONTAINER / CONNECTION	<ul style="list-style-type: none"> a) any fuel tank not securely attached to the vehicle b) any part of the fuel system not properly secured or fastened c) any liquid fuel leak at any point 	
10.90	DRIVE SHAFT		
10.91	DRIVE SHAFT GUARD	Loose or Missing	

ITEM NO.	INSPECTION ITEM	DEFECT	ACTION
11.00	DIFFERENTIAL	Cracked housing	
11.10	ENGINE		
11.11	COMPONENTS	Any critical component that fails to function as designed	
11.12	LEAKS	Any fluid leaks that would affect the safe operation of the engine	
11.20	TIRES/WHEELS/ HUBS		
11.21	TIRE TREAD DEPTH	Any tire worn less than 2/32 inch, (4/32 inch on steering axle)	
11.22	TIRE SIDEWALL	a) any sidewall that is cut, worn, or damaged to the extent that the plycord is exposed b) any observable bump, bulge, or knot related to sidewall or tread separation	
11.23	TIRE INFLATION	Tire is flat or has noticeable leak	
11.24	TIRE TYPE	Not of proper type (load range, size, mismatched, etc.)	
11.25	WHEELS/RIM/ SPIDERS	a) any nuts, bolts, studs, lugs, missing, damaged or loose b) any wheel/rim is cracked, improperly seated, damaged, or welded	
11.26	HUB	Excessive wheel bearing play that exceeds OEM specifications	
11.30	AISLE		
11.31	CLEARANCE	Aisle does not have the required clearance	
11.32	OBSTRUCTION	There are objects blocking aisles or exits	
11.40	ELECTRICAL		
11.41	WIRING	Any required wire or electrical component charred or showing evidence of being burnt or exposed	
11.50	BATTERY		
11.51	CONDITION	Battery will not activate the starter	
11.52	WIRES	Wiring is exposed or loose	
11.53	BATTERY SECUREMENT	Battery not secured	
11.60	WINDSHIELD WIPERS		

ITEM NO.	INSPECTION ITEM	DEFECT	ACTION
11.70	BODY INTERIOR		
11.71	PANELS	Any panel (ceiling, side, wheel well, etc.) protruding, having sharp edges, or not secured, that may cause injuries	
11.72	FLOORS	Floor pan or inner panels having excessive perforated areas or openings sufficient to cause a hazard to an occupant	
11.73	STEP WELL	Any part of the step well or support structure is damaged	
11.74	STEP TREADS	Any condition that would present a tripping hazard	
11.75	HANDRAIL	a) missing	
		b) fails the nut/drawstring test or has not complied with recall. (See chart # 3)	
11.76	SEATS/BARRIERS	a) any seat/barrier that is not secured properly	
		b) any seat/barrier material so defective that it compromises the integrity of occupant protection and compartmentalization	
		c) seat spacing fails to comply with FMVSS No. 222	
11.77	SEAT(Driver)	a) fails to adjust or hold proper adjustment.	
		b) any part of the driver's safety restraint assembly is missing, not properly installed or so defective as to prevent proper securement	
11.78	DOORS (Service)	a) the service door does not open or close properly b) the door control handle does not lock in the closed position c) door is equipped with a padlock or similar non-OEM locking device. (Excludes vehicles equipped with an interlock system)	
11:79	DOORS (Emergency Exits)	a) any emergency door that does not open freely or completely, as designed b) any door(s) warning device that is defective c) door or roof hatch is equipped with a padlock or similar non-OEM locking device (Excludes vehicles equipped with an interlock system)	

ITEM NO.	INSPECTION ITEM	DEFECT	ACTION
11.80	WINDOWS	a) any glass or glazing that is broken through or missing b) not of approved type c) every school vehicle windshield shall be free of discoloration or other damage in that portion thereof extending upward from the height of the topmost portion of the steering wheel, but not including a one inch border at the top and a one-inch border at each side of the windshield or each panel thereof, except that discoloration and damage as follows are allowed: (1) coloring or tinting applied during manufacture, for reduction of glare; (2) any crack not over ___-inch wide, if not intersected by any other crack; (3) any damaged area which can be covered by a disc 3/4 inch in diameter, if not closer than 3 inches to any other such damaged area d) driver's side area window(s) have chips, clouding or cracks that obscure the driver's vision	
11.81	WINDOWS (Emergency Exits)	a) any Emergency window that fails to open properly b) lacks the required number of emergency windows/roof hatches. (Fails to comply with FMVSS No. 217) c) required audible warning device(s) not working properly	
11.82	DEFROSTERS	Fails to operate	
11.90	BODY EXTERIOR		
11.91	PANELS, RUB RAILS, TRIM	Any school bus body part that is loose, torn, dislocated or protruding from the surface of the bus, creating a hazard	
11.92	COMPARTMENT DOORS	Any engine, battery or other doors that are not secured properly	
11.93	MIRRORS	Any required mirror missing, broken, discolored or will not hold a set adjustment	
12.00	LAMPS AND SIGNALS		

ITEM NO.	INSPECTION ITEM	DEFECT	ACTION
12.01	HORN	Fails to function as designed	
12.02	GAUGES/BRAKE WARNING	Any critical brake, telltale light, buzzer or gauge that fails to function as designed	
12.03	STOP ARM / OPTIONAL CROSSING DEVICE	Required stop arm(s), or if equipped any crossing control device fails to function properly	
12.10	EMERGENCY EQUIPMENT		
12.11	FIRE EXTINGUISHER	Any required fire extinguisher(s) which is missing, not of proper type / size, not fully charged, has no pressure gauge, is not secured or is not accessible to the driver	
12.20	WHEELCHAIR EQUIPPED VEHICLES	a) wheelchair lift does not function as designed or is inoperable	
		b) any hydraulic line leaking during lift operation c) wheelchair securement missing or improperly installed loose or damaged d) any required wheelchair occupant restraint system not in compliance with FMVSS No. 222	

TABLE 1 BRAKE ADJUSTMENT

Brake Adjustment: Shall be less than those specifications contained herein relating to "Brake Adjustment Limit".
(Dimensions are in inches.)

<u>CLAMP TYPE BRAKE CHAMBER DATA</u>		
<u>TYPE</u>	<u>OUTSIDE DIAMETER</u>	<u>BRAKE ADJUSTMENT LIMIT</u>
6	4 _	1 1/4
9	5 1/4	1 3/8
12	5 11/16	1 3/8
16	6 3/8	1 3/4
20	6 25/32	1 3/4
24	7 7/32	1 3/4
30	8 3/32	2
36	9	2 1/4

<u>'LONG STROKE' CLAMP TYPE BRAKE CHAMBER DATA</u>		
<u>TYPE</u>	<u>OUTSIDE DIAMETER</u>	<u>BRAKE ADJUSTMENT LIMIT</u>
16	6 3/8	2.0
20	6 25/32	2.0
24	7 7/32	2.0
24+	7 7/32	2.5
30	8 3/32	2.5
* For 3" maximum stroke type 24 chambers		

<u>TIE ROD STYLE PISTON BRAKE CHAMBER DATA</u>		
<u>SIZE</u>	<u>OUTSIDE DIAMETER</u>	<u>BRAKE ADJUSTMENT LIMIT</u>
30	6 _ (165mm)	2.5 (64mm)

TABLE I BRAKE ADJUSTMENT (continued)

BOLT TYPE BRAKE CHAMBER DATA		
<u>TYPE</u>	<u>OUTSIDE DIAMETER</u>	<u>BRAKE ADJUSTMENT LIMIT</u>
A	6 15/16	1 3/8
B	9 3/16	1 3/4
C	8 1/16	1 3/4
D	5 1/4	1 1/4
E	6 3/16	1 3/8
F	11	2 1/4
G	9 7/8	2

ROTO CHAMBER DATA		
<u>TYPE</u>	<u>OUTSIDE DIAMETER</u>	<u>BRAKE ADJUSTMENT LIMIT</u>
9	4 9/32	1 _
12	4 13/16	1 _
16	5 13/32	2
20	5 15/16	2
24	6 13/32	2
30	1 1/6	2 1/4
36	7 5/8	2 3/4
50	8 7/8	3

DD-3 BRAKE CHAMBER DATA		
<u>TYPE</u>	<u>OUTSIDE DIAMETER</u>	<u>BRAKE ADJUSTMENT LIMIT</u>
30	8 1/8	2 1/4

NOTE: This chamber has three air lines and is found on motor coaches.

WEDGE BRAKE DATA		
The combined movement of both brake shoe lining scribe marks shall not exceed 1/8 inch (3.18mm).		

TABLE 2-STEERING WHEEL FREE PLAY

Steering Wheel Free Play: Steering wheel free play shall not exceed the requirements listed in the following chart:

Steering Wheel Diameter	Manual System Movement 30N	Power System Movement 45N
16" (41cm)	2"(5.1cm)	4 _" (11.5cm)
18" (46cm)	2 1/4" (5.4cm)	4 3/4" (12cm)
20" (51cm)	2 _" (6.4cm)	5 1/4" (13.5cm)
22" (56cm)	2 3/4" (7cm)	5 3/4" (14.5cm)

TABLE 3 - HANDRAIL INSPECTION TOOL & PROCEDURE

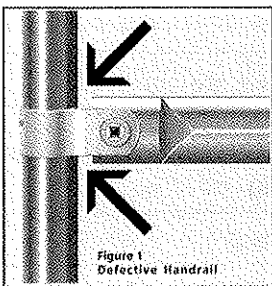

Across the United States, children are being injured or killed when their clothing or accessories are caught in their school bus's handrail or door as they exit the school bus. As a result, they may fall and be violently dragged by the bus and run over by its rear wheels. The most common piece of clothing that can be snagged on the handrail is a jacket with a drawstring at the waist. These drawstrings commonly have a large bobble or knot at the ends that can become lodged in the handrail. However, other articles such as scarves, long straps on backpacks or dangling key chains can also be snagged on the handrail. School bus handrails have had the same basic design for more than 30 years. However, with the current change in fashion toward oversized and baggy clothing, handrail designs have contributed to tragic and avoidable injuries and deaths. Typical handrail designs that have the potential for snagging are illustrated in Figures 1 and 2.

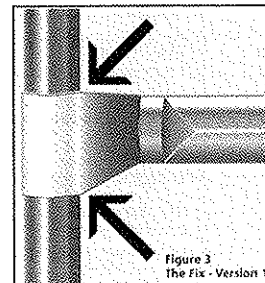

School bus manufacturers have taken extraordinary and costly steps to remove snagging hazards from school bus entrances. More than 400,000 school buses have been recalled and manufacturers have absorbed the cost of the repairs. In most cases, a simple spacer can be added to the existing handrail eliminating the potential for snagging. In other cases, manufacturers have redesigned the handrail. Figures 3 and 4 illustrate handrails that have been modified.

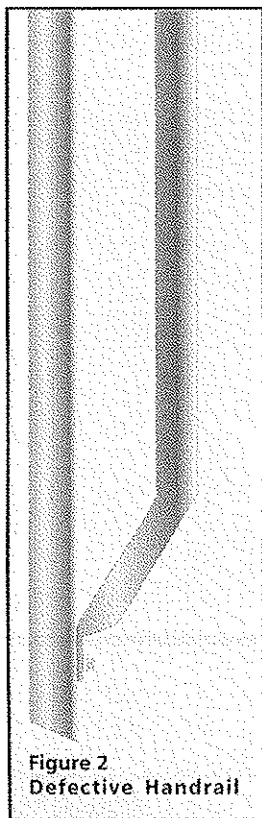

The school bus driver is a trained professional concerned with getting children to school and returning them home safely. Driving a school bus is a demanding task. There is a lot of activity in and around the bus. The bus driver must be aware of ever-changing traffic conditions, the children on the bus, and the children who enter and exit at each school bus stop. Compounding this already complex situation is the need for the driver to maintain the school bus schedule.

The major reason for injury and death due to handrail snagging incidents is the driver's failure to notice that the child's drawstring has become snagged. The driver should observe all children, especially those with long drawstrings, oversized or baggy clothing, or other items that may become snagged in handrails, as they exit. Additionally, to ensure safety at each stop, the driver should be certain that each child has completely exited the bus and cleared the danger zones before closing the door and moving the vehicle. The driver should secure the bus and check around and underneath the bus if there is a question of whether a child has moved safely away from the bus. Finally, the driver must be alert for warnings as the bus pulls away. In many of the snagging incidents that have occurred to date, someone inside or outside the bus attempted to warn the driver that a child was being dragged by the bus.

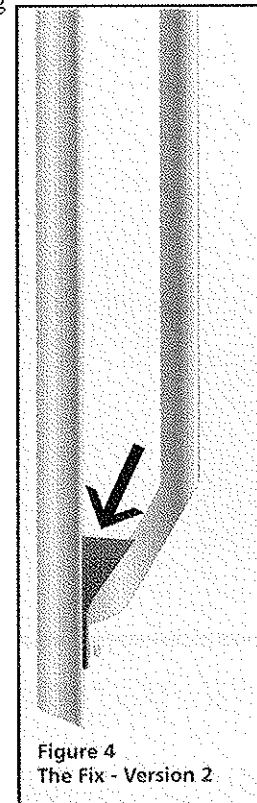

Childrens' and Parents' Responsibilities

Children and parents must also accept some responsibility for ensuring that a snagging incident does not occur. While oversized and baggy clothing may represent the latest fashion trend, try to avoid choosing any article that may become caught in a school bus handrail or door. The Consumer Product Safety Commission recommends that drawstrings be no more than three inches in length at the waist. Parents should caution children about attaching key rings and other items to their backpacks as these too may become caught on the handrail or door.

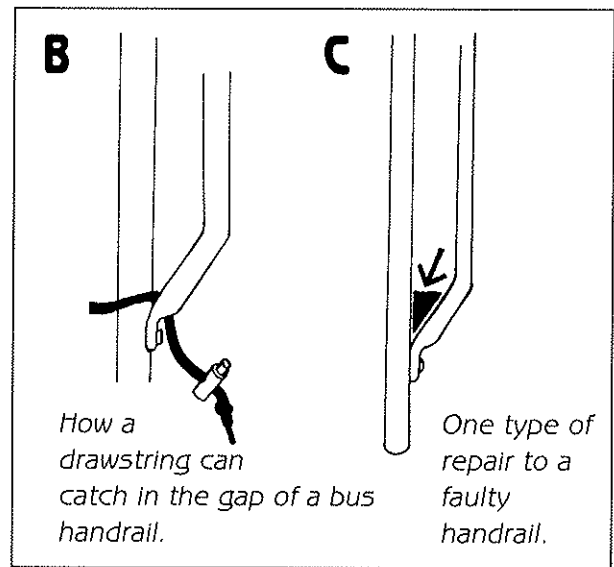

INSPECTION ITEMS AND CRITERIA UTILIZED THAT ARE UNIQUE TO SCHOOL BUSES WERE REFERENCED FROM THE FOLLOWING SOURCES:

FEDERAL GUIDELINE # 17

FEDERAL MOTOR VEHICLE SAFETY STANDARDS

FEDERAL MOTOR CARRIER (PART 393)

MOTOR VEHICLE MANUFACTURERS ASSOCIATION (MVMA) INSPECTION HANDBOOK

COMMERCIAL VEHICLE SAFETY ALLIANCE UNIFORM OUT-OF-SERVICE CRITERIA (CVSA)

LAWS, REGULATIONS AND STATUTES FROM THE FOLLOWING STATES:

California, Connecticut, Michigan, Maryland, Ohio, Missouri, New York, New Jersey, North Carolina, Indiana, Oregon, and Washington

MANUFACTURERS MAINTENANCE MANUALS FROM

American Transportation, Blue Bird Body Company, Carpenter Industries, Inc., Thomas Built Buses, International, GMC, Chrysler, and Ford

SCHOOL BUS INSPECTORS

SCHOOL BUS MANUFACTURERS

POLICE AGENCIES

STATE DIRECTORS

TRANSPORTATION CONSULTANTS

APPENDICES

A – H

APPENDICES

A-H

APPENDIX A
Terms and
Definitions



APPENDIX A

Glossary of Terms and Definitions

INTRODUCTION

This glossary was developed with three purposes in mind:

1. To provide easy access to the definition of terms used or referenced within the document;
2. To consolidate, in one resource, the acronyms, abbreviations and standard terms commonly used in the industry; and
3. To promote consistency throughout the industry by providing standard definitions or preferred usages for terms that may be used differently in different parts of the country.

The glossary is not intended to be definitive. There are and will be terms that are excluded and definitions that differ from regional usages. It is an attempt to reflect the language of pupil transportation which, like all language, is ever-changing.

Access panel: A body panel which must be moved or removed to provide access to one or more serviceable components.

Accessibility: Ability of vehicles and facilities to accommodate people with disabilities.

Activity trip: The transportation of students to any event sanctioned for pupil attendance or authorized by an officer, employee or agent of a public or private school, other than to-and-from school transportation. (See also *field trip*.)

ADA: The Americans with Disabilities Act, PL 101-336, 42 USC 12101, *et seq.*

Adaptive device: Any item or piece of equipment used to increase, maintain or improve functional capabilities of children with disabilities. Also known as *assistive technology device*.

Aide: (See *attendant*.)

Alcohol: The intoxicating agent in beverage alcohol, ethyl alcohol, or other low molecular weight alcohols including methyl and isopropyl alcohol.

Alternately flashing signal lamps: A system of red or red and amber signal lamps mounted horizontally both front and rear, intended to identify a vehicle as a school bus and to inform other users of the highway that the bus is about to stop or is stopped to load or unload children; also known as *stop signal lamps*, *SOS lights* or *school bus traffic warning lights*.

Alternative-fuel vehicle: A vehicle designed to operate on an energy source other than gasoline or regular grades of diesel. Such fuels include, but are not limited to, CNG, LNG, LPG, advanced diesel fuel formulations and electricity.

Bi-fuel: A vehicle designed to operate on two different fuels, but not simultaneously.

Dual fuel: A vehicle designed to operate on a mixture of two different fuels.

Hybrid power: The use of two or more power sources to provide the motive force for the vehicle (e.g. electricity to drive the wheels with internal combustion to supplement the battery).

Anchorage point: The point of attachment of a securement system or occupant restraint to the vehicle structure.

ANPR: Advanced Notice of Proposed Rulemaking. Notice published in the *Federal Register* by a federal agency, such as NHTSA, requesting information and inviting comment on a proposed change of regulation.

ANSI: American National Standards Institute, the organization which administers and coordinates the development of voluntary industry standards.

Antilock brakes: Brake systems with sensors that automatically control the degree of wheel slip during braking and that relieve brake pressure on wheels that are about to lock up.

Aspect ratio: Percentage used to express the ratio of a tire's height to its width; also known as *tire profile*.

Assessment team: A group of persons, including the parent or guardian of a student with disabilities, who develop a profile of the student in terms of his or her mental and physical functioning in order to determine the student's eligibility for special education. (See also *MDC*.)

Assistive device: (See *adaptive device*.)

Attendant: A person assigned to assist one or more individual student(s) with disabilities on a school bus or school vehicle; also known as *aide* or *paraprofessional*. (See also *monitor*.)

BAC: Blood or breath alcohol concentration; the measure used to determine alcohol impairment.

BAT: Breath Alcohol Technician; an individual who instructs and assists persons in the alcohol testing process and operates an EBT.

Behavior management: Methods of influencing student conduct on the school bus.

Biodiesel: Vehicle fuel made from plant matter and commonly mixed with diesel fuel in engines.

Bloodborne Pathogens: Common name for standards adopted by OSHA in 29 CFR 1910, to protect workers against the health hazards of exposure to blood and other potentially infectious body fluids or materials; also refers to the pathogenic microorganisms present in human blood.

Boarding: The process of loading passengers into a school bus.

Body fluids cleanup kit: Package of materials including, but not limited to, latex gloves, disposal bag and absorbent material, used to clean up spills of potentially infected bodily fluids, under OSHA's Bloodborne Pathogens regulations and Universal Precautions practices; also known as *hygiene kit*.

Brake: A device or mechanism used to retard and stop the speed of a moving vehicle or to prevent the movement of a stopped vehicle.

Emergency brake: A mechanism designed to stop a motor vehicle after a failure of the service brake system.

Retarder: An auxiliary braking device used to reduce brake wear.

Service brake: The primary mechanism designed to retard and stop a moving vehicle.

Parking brake: A mechanism designed to prevent the movement of a stationary motor vehicle.

Brake fade: A condition that occurs as brakes become less effective.

Bus: A motor vehicle with motive power, except a trailer, designed for carrying more than ten (10) persons.

Activity bus: A bus owned, leased or contracted by a school district and regularly used to transport students on field trips, athletic trips or other curricular or extracurricular activities, but not used for to-and-from school transportation; must meet all FMVSSs for school buses.

Charter bus: A bus that is operated under a short-term contract with a school district or other sponsor who has acquired the exclusive use of the vehicle at a fixed charge to transport students to a school-related event.

DOT bus: A school bus that meets the FMCSR standards for interstate transportation set forth in 49 CFR 390.

Intercity bus: A large bus with front doors only, high-back seats and under-floor luggage storage for high-speed, long distance trips; also known as *motor coach* and *over-the-road coach*.

Nonconforming bus: Any vehicle designed to carry more than ten (10) passengers that is used to transport children to or from school or school-related activities which does not meet the federal standards specific to school buses.

School bus: A bus owned, leased, contracted to or operated by a school or school district and regularly used to transport students to and from school or school-related activities, but not including a charter bus or transit bus; must meet all applicable FMVSSs, and is readily identified by alternately flashing lights, National School Bus Yellow paint, and the legend "School Bus."

Type A: A Type "A" school bus is a conversion or bus constructed utilizing a cutaway front-section vehicle with a left side driver's door. This definition includes two classifications: Type A-1, with a Gross Vehicle Weight Rating (GVWR) of 10,000 pounds or less; and Type A-2, with a GVWR greater than 10,000 pounds.

Type B: A Type "B" school bus is constructed utilizing a stripped chassis. The entrance door is behind the front wheels. This definition includes two classifications: Type B-1, with a GVWR of 10,000 pounds or less; and Type B-2, with a GVWR greater than 10,000 pounds.

Type C: A Type "C" school bus is constructed utilizing a chassis with a hood and front fender assembly. The entrance door is behind the front wheels; also known as a *conventional school bus*.

Type D: A Type "D" school bus is constructed utilizing a stripped chassis. The entrance door is ahead of the front wheels; also known as *transit-style school bus* or *forward-control vehicle*.

Specially equipped: A school bus designed, equipped, or modified to accommodate students with special needs.

Transit bus: A bus designed for frequent stops, with front and back-center doors and low-back seating, operated on a fixed schedule and route to provide public transportation by indiscriminately taking on passengers at designated bus stops.

Bus body: The portion of a bus that encloses the occupant space exclusive of the bumpers, the chassis frame, and any structure forward of the forward-most point of the windshield mounting.

Bus pass: Authorization to ride a school bus other than the student's assigned bus; or prepayment for transit bus rides.

Bus yard: An area for storage and maintenance of buses.

CAA: Clean Air Act; also known as *CAAA*, the Clean Air Act Amendments of 1990.

Capacity: (See *seating capacity*.)

Capital costs: Long-term costs associated with the purchase of vehicles, buildings and property.

Captive: Refers to a non-removable attachment, part or fitting on a securement system.

Carrier: Any public school district, any public or private educational institution providing preschool, elementary or secondary education, or any person, firm or corporation under contract to such a district or institution, engaged in transporting students.

Casualty insurance: (See *liability insurance*.)

CDIP: Commercial Drivers Instructional Permit. The learner's permit that a CDL applicant receives when he/she passes the knowledge tests; it allows the applicant to drive a CMV when accompanied by a driver with a CDL.

CDL: Commercial Drivers License.

CFR: Code of Federal Regulations.

Chassis: Vehicle frame with all operating parts, including engine frame, transmission, wheels and brakes.

Chassis starting interlock circuit: A device which prevents the engine of a bus from starting if any of the emergency exits are locked.

CMV: Commercial motor vehicle. A motor vehicle defined in 49 CFR 390.5.

CMVSA: Commercial Motor Vehicle Safety Act of 1986; among other things, authorization for CDL.

CNG: Compressed natural gas.

Common carrier: A public bus, train or airplane that travels on a prescribed route and schedule, and accepts passengers indiscriminately.

Communicable disease: Any illness that can be transmitted from one person to another, including most common childhood diseases, the common cold and serious illnesses such as hepatitis and AIDS.

Community transportation: Services that address all transit needs of a community, including general and special populations, such as the elderly and disabled.

Companion animal: An animal trained to provide assistance for persons with disabilities; can be a guide animal, assistive animal or service animal.

Completed vehicle: A vehicle that requires no further manufacturing operation to perform its intended function other than the addition of readily attachable components, such as mirrors or tire and rim assemblies, or minor finishing operations such as painting.

Conduct report: A form authorized by school officials for use by drivers to report instances of unacceptable behavior by school bus passengers; also known as *discipline report*.

Continuum of services: The range of possible options, from least restrictive to most restrictive, available to students with disabilities for transportation services.

Conspicuity: The ability of an object to be noticed and recognized without any confusion or ambiguity (SAE J1967).

Crash, school bus: (1) A motor vehicle crash involving a school bus with or without a pupil on board, resulting in any personal injury or death or any disabling damage to one or more motor vehicles requiring the vehicle(s) to be transported away from the scene by a tow truck or other vehicle; or (2) A collision involving any vehicle or any pupil or school bus at any time during the loading or unloading process.

Preventable: A crash that could have been prevented by reasonable action on the part of the school bus driver.

Reportable: A crash required to be reported under FMCSR (i.e. a crash involving a CMV on a public road in which there is a fatality or an injury treated away from the scene, or that requires a vehicle to be towed from the scene).

Crash test: (See *impact test*.)

Criminal record check: The investigation of a person's criminal history through submission of fingerprints to state and/or federal authorities; also known as *background check*.

Crossing arm: A device attached to the front bumper of a school bus, activated during loading and unloading and designed to force the students to walk far enough away from the front of the bus to be seen by the driver; also known as *crossing control arm*.

CSRS: Child Safety Restraint System; a device meeting the requirements of FMVSS No. 213, designed for use in a motor vehicle to restrain, seat or position a child who weighs less than 50 pounds; also known as *child safety seat* and *car seat*.

Curb cut: Area where the street curb has been cut and sloped to allow the sidewalk to lead smoothly to the roadway.

Curb weight: The weight of a motor vehicle with standard equipment, maximum capacity of engine fuel, oil, and coolant and, if applicable, air conditioning and additional weight of optional engine, but without passengers.

Danger zone: A ten-foot area immediately surrounding the stopped school bus.

Deadhead: Movement of a bus without passengers (e.g., from school to bus yard).

Deadtime: The period between arriving at an activity trip destination and leaving the destination for the trip home; also known as *waiting time* and *stand-by time*.

Dealer: Any person who is engaged in the sale and distribution of new motor vehicles or motor vehicle equipment. Primarily to purchasers who, in good faith, purchase any such vehicle or equipment for purposes other than resale.

Distributor: Any person primarily engaged in the sale and distribution of motor vehicles or motor vehicle equipment for resale.

Dispatch: To relay service instructions to drivers.

DNR: Do Not Resuscitate; an order from a parent, legal guardian or court that prohibits the use of emergency measures to prolong the life of an individual.

DOT: United States Department of Transportation.

DOT driver: A driver who meets the FMCSR standards, set forth in 49 CFR 391.

Double run: One bus making two trips over the same route each morning and afternoon (e.g. first picking up high school students and then returning for elementary students.)

Downtime: The period when a vehicle is inoperative (e.g. due to mechanical failure.)

Driver applicant: A person who applies for a position as a school bus driver.

Driver training: Instructional program designed to impart knowledge and improve the skills necessary for school bus drivers, including but not limited to knowledge of the vehicle, safe driving practices, emergency procedures and passenger control.

In-service: Training provided annually or more often to school bus-certified drivers.

Pre-service: Training provided to driver applicants prior to school bus certification and/or transporting students.

Driver qualifications: Restrictions of state and federal law which determine a person's eligibility to become a school bus driver (e.g. age limits, physical condition, criminal record, driving history, etc.)

DRL: Daytime running lamps; Head lamps that operate automatically at a reduced voltage during the day to increase the vehicle's visibility; also known as *daytime running lamps*.

Drug: Any substance other than alcohol considered to be a controlled substance listed on schedules I through V in 21 CFR 1308.

Dry run: A trip on a route without student passengers for driver training or familiarization of the route.

Dual brake system: (See *split brake system*.)

Dual fuel system: (See *alternative fuel*.)

DVIR: Driver vehicle inspection report. Federal, state or local approved form for reporting results of pre-trip and post-trip inspections; also known as *daily vehicle inspection report* and *pre-trip inspection form*.

Dynamic testing: The process of subjecting vehicle, mobility aid, or mobility aid/securement system components to a simulated crash condition.

EAP: Employee Assistance Program; a program of education and counseling required by 49 CFR 391 as part of a carrier's drug and alcohol testing program; may also include optional rehabilitation services.

EBT: Evidential Breath Testing device; a device approved by NHTSA for testing drivers for alcohol use.

EDR: Event Data Recorder; a device which records vehicle functions (e.g. speed change during a crash.)

EHA: The Education for all Handicapped Children Act, passed in 1975 as P.L.94-142. (*See IDEA*).

EPA: The United States Environmental Protection Agency.

Early bus: A bus scheduled to run prior to the regular morning run (e.g. to take children to day care programs located in schools.)

Early intervention service: Education and related services provided to infants and toddlers from birth through two years of age.

Effective date: The date at which a regulation or standard takes effect, on or after which compliance is legally required.

Electronic voice communication system: A means by which the driver of a vehicle can communicate with a dispatcher or other person at a remote location (e.g., two-way radio, cellular phone.)

Emergency roof exit: An opening in the roof of the bus meeting the requirements of FMVSS No. 217 which provides emergency egress and sometimes ventilation; also known as *roof hatch*.

Emergency response plan: A detailed approach to identifying and responding to potential accidents involving hazardous substances; required for every community by the Emergency Planning and Right-to-Know Act of 1986.

Ergonomics: The study of the design of equipment to reduce human fatigue and discomfort.

Ethanol: Grain alcohol, distilled from fermented organic matter and used as a vehicle fuel.

Evacuation drill: Performance of a mock school bus evacuation in order to teach students proper emergency procedures and to provide practice in the use of emergency exits; also known as *bus safety drills*.

Extended-year service: Transportation provided for students subsequent to the end of the traditional school year.

Extraboard driver: (*See substitute driver.*)

FAPE: Free Appropriate Public Education; guaranteed by the EHA for all handicapped children; it includes special education and related services, including transportation.

FBI background check: The national criminal record check.

FERPA: The Family Educational Rights and Privacy Act of 1974, 20 USC 1232, which requires confidentiality of student records in public schools, but allows access to necessary information regarding student disabilities and/or health needs to those who have a need to know, including school bus drivers.

FHWA: Federal Highway Administration, an agency of the U.S. Department of Transportation.

- Field trip:** The transportation of students to an event or destination which is an extension of classroom activity (i.e., a part of the curriculum). A field trip is one type of *activity trip*.
- Final Rule:** Notice published in the *Federal Register* by a federal agency announcing a new or changed regulation.
- Final stage manufacturer:** A person who performs such manufacturing operations on an incomplete vehicle that it becomes a completed vehicle.
- First aid:** Emergency treatment given to an ill or injured person before regular medical help is available.
- Fixed route:** Transportation service that runs on regular, prescheduled routes, usually with bus schedules and designated bus stops.
- FMCSA:** Federal Motor Carrier Safety Administration; an agency of the U.S. Department of Transportation; formerly the Office of Motor Carrier Highway Safety within the Federal Highway Administration.
- FMCSR:** Federal Motor Carrier Safety Regulations, 49 CFR 383, 390-397, and 399; motor vehicle safety and construction standards under FMCSA that apply to commercial motor vehicles and drivers transporting passengers in interstate commerce.
- FMLA:** Family and Medical Leave Act; requires employers to grant time off to employees for medical reasons or to care for family members.
- FMVSS:** Federal Motor Vehicle Safety Standards, 49 CFR 571; construction standards developed and enforced by NHTSA that apply to all new motor vehicles and items of motor vehicle safety equipment.
Final Rule: Notice published in the *Federal Register* by a federal agency announcing a new or changed regulation.
- Forward control bus:** a school bus in which more than half of the engine length is rearward of the foremost point of the windshield base and the steering wheel hub is in the forward quarter of the vehicle length; also known as *transit-style*.
- Forward-facing:** Installation of the securement system in such a way that the mobile seating device and its occupant face the front of the vehicle when secured.
- Four-point tiedown:** A securement system in which four strap assemblies attach to the wheelchair frame at four separate points and anchor to the vehicle floor at four separate points.
- FSS:** Fire suppressant system; a fire extinguisher system installed in the engine compartment of a vehicle and activated automatically in response to a fire sensor or manually in response to an alarm.
- FTA:** Federal Transit Administration, part of U.S. Department of Transportation; formerly Urban Mass Transit Administration (UMTA).
- Fuel injection:** System that uses no carburetor but sprays fuel directly into cylinders or into the intake manifold.
- Glazing:** The glass or glass-like portion of a window.
- Laminated glass:** Any glazing material that consists of one or more sheets of glass and an inboard-facing surface sheet of plastic, the components being held together by intervening plies of plastic interlayer or by the self-bonding characteristic of the inboard plastic layer.

- Safety glass:** Glazing material constructed, treated or combined with other materials so as to reduce, in comparison with ordinary glass, the likelihood of injury to persons as a result of contact with the glass, either broken or unbroken.
- Storm window:** Two or more sheets of safety glazing material separated by an airspace to provide insulating properties and fixed in a common frame or mounting.
- Tempered glass:** Glazing which consists of glass that has been tempered to meet the properties of safety glass.
- GAWR:** Gross axle weight rating; the value specified by the manufacturer as the load-carrying capacity of a single axle system, as measured at the tire-ground interfaces.
- Guideline 17:** A highway safety program guide for pupil transportation safety issued by NHTSA in 23 CFR 1204.; formerly Standard 17.
- GVWR:** Gross vehicle weight rating; the value specified by the manufacturer as the loaded weight, with passengers, of a single vehicle.
- Handrail inspection tool:** A device formed by tying a half-inch hex nut to a 36" cord, used to inspect school bus handrails and other areas for possible snagging hazards.
- Hazard lamps:** Lamps that flash simultaneously to the front and rear on the right and left sides of a vehicle, used to indicate caution; also known as *four way flashers*.
- Head protection zone:** The empty space above and in front of each school bus passenger seat which is not occupied by side wall, window or door structure, the dimensions of which are detailed in FMVSS No. 222.
- Head Start:** A program initiated in 1965 to provide comprehensive child development services to pre-school children of predominantly low-income families.
- Headsign:** A sign above the windshield of the bus which can be changed from *School Bus* to other wording, such as *Charter*.
- Health care plan:** A plan of action used to outline the care for a medically fragile individual.
- Highway:** Any public highway, road, street, alley, parkway or other place open to public motor vehicle travel.
- Horsepower:** The measurement of an engine's ability to do work. One horsepower is the ability to lift 33,000 lbs. one foot in one minute.
- Hours of service:** The consecutive or cumulative period of time that a commercial driver may be on duty; for details see reference in the section "Transportation Other Than To and From School" of Operational Procedures.
- HOV:** High Occupancy Vehicle; a vehicle that can carry two or more passengers.
- ICC:** The former Interstate Commerce Commission, the economic regulation agency within the Department of Transportation. The agency was disbanded in 1997 as a result of economic deregulation, and most functions were transferred to the Federal Highway Administration.
- IDEA:** The Individuals with Disabilities Education Act, passed in 1990 as P.L. 101-476 (Part B) as approved in March of 1999, to replace the EHA.

IEP: Individualized Education Program; a plan including information for each child with disabilities required under P. L. 101-476 (Part B).

IFSP: Individualized Family Service Plan; a written plan similar to the IEP for the family of a child receiving early intervention services required under P.L. 102-119.

Impact test: A simulated crash condition which evaluates the ability of a vehicle or any component or device to withstand crash forces; also known as *sled test* and *crash test*.

Inclusion: Integration of a student with disabilities into a regular classroom and onto a regular school bus; also known as *mainstreaming*.

Incomplete vehicle: An assemblage consisting, as a minimum, of frame and chassis structure, power train, steering system, suspension system and braking system (to the extent that those systems are to be part of the completed vehicle) and requiring further manufacturing operations other than the addition of readily attachable components, such as mirrors and tire and rim assemblies, or minor finishing operations such as painting, to become a completed vehicle.

Injury incident, school bus: Any non-crash injury sustained by a person while in the bus, or while boarding/leaving the bus.

Inspection: A close examination of a motor vehicle performed in accordance with local, state and/or federal requirements by an authorized agent of the local, state or federal government.

Integrated restraint system: A system in which the occupant restraint of an individual in a wheelchair/mobility aid connects directly to, and is dependent upon, the mobility aid's securement system's rear strap assemblies.

Intermediate manufacturer: A person, other than the incomplete vehicle manufacturer or the final-stage manufacturer, who performs manufacturing operations on an incomplete vehicle.

International symbol of accessibility: A white emblem on blue background used to indicate that a vehicle can accommodate individuals with disabilities.

Kneeling bus: A bus on which the front or rear end is lowered to allow easier access for passengers with disabilities.

Lap belt: A Type 1 belt assembly meeting the requirements of FMVSS No. 209, intended to limit movement of the pelvis.

Lap/shoulder belt: A Type 2 belt assembly meeting the requirements of FMVSS No. 210, intended to limit the movement of the pelvis and upper torso.

Lap tray: An accessory for a wheelchair or other mobile seating device, to offer support and convenience for the occupant.

Late bus: A bus scheduled to leave school at a time subsequent to the end of the school day, usually to provide transportation for students involved in after-school activities.

Layover time: Time built into a trip schedule between arrival and departure.

LEA: Local Education Agency.

Left: Left position is determined from the normal driving position as seated in the driver's seat looking in the direction of forward travel.

Liability insurance: Protection against the claims of others for injury or property damage; also known as *casualty insurance*.

Life cycle procurement: A procurement contract based on both the initial capital cost and the cost of operation over the life of a vehicle.

Lift: (See *power lift*.)

Live time: The time when students are on the bus, beginning when the first passenger boards and ending when the last passenger leaves.

LNG: Liquid Natural Gas.

Load: To pick up students at a designated bus stop or at school.

Load factor: The ratio of passengers actually carried to the vehicle's passenger capacity.

Loading zone: Any area where students are boarding or leaving a school bus.

Low-bid procurement: Competitive procedure in which the lowest bidder is awarded the contract.

Low-floor vehicle: A bus in which the floor and entrance are closer to the ground, for easier access by students with disabilities or pre-schoolers.

Longitudinal: Parallel to the longitudinal centerline of the vehicle, front to rear.

LPG: Liquid Petroleum Gas; also known as *propane*.

LRE: Least Restrictive Environment; a concept embodied in IDEA which requires that children with disabilities be integrated as fully as possible into situations and settings with their nondisabled peers.

Mainstreaming: (See *inclusion*.)

Manufacturer: Any person engaged in the manufacturing or assembling of motor vehicles or item of motor vehicle equipment, including any person importing motor vehicle equipment for resale.

MDC: Multi-Disciplinary Conference; an assessment meeting for a student with disabilities which leads to an IEP. (See also *assessment team*.)

Mediation: Efforts by a third party to bring about agreement between dissenting parties (e.g. labor and management or parents and school administration); usually less formal than arbitration.

Medical support equipment: Portable equipment used by students to maintain life functions, such as oxygen bottles, intravenous or fluid drainage apparatus.

Medically fragile: Refers to students who require specialized technological health care procedures for life support and/or health support.

Minibus: A small school bus, usually a Type A-1 or A-2 or Type B-1 or B-2.

Minivan: A multi-purpose vehicle (MPV) designed to carry seven to ten passengers.

Mirrors: The system of mirrors required to be installed on school buses in accordance with FMVSS No. 111 and applicable state laws.

Crossview: Convex mirrors mounted on the front of the school bus and designed for student detection during loading and unloading, including *elliptical, quadri spherical, banana, or standard convex*; also known as *System B mirrors*.

Driving: Flat and convex mirrors mounted on each side of the bus designed for viewing the road along the sides to the rear while driving; also known as *rearview, double nickel, west coast, or System A mirrors*.

MIS: Management Information System; a means of data collection for analysis by management.

Mobility aid: A wheelchair or other device, either battery-powered or manual, that is used to support and convey a person with a physical disability; also known as *mobile seating device*.

Modesty panel: A panel located in front of a seat or row of seats, usually supported by a stanchion and cross bar, which does not meet the performance standards of a barrier as defined in FMVSS No. 222; or a short panel which extends from the bottom of a barrier to or near to the floor for the purpose of reducing the draft from the entrance door; also known as *kick panel*.

Monitor: A person assigned to assist the driver on a school bus or school vehicle.

Discipline: A monitor whose primary responsibility is to control behavior of students on the bus.

Safety: A monitor whose primary responsibility is to ensure the safety of students getting on and off the bus and to check the loading zone before the driver pulls out.

MPV: Multipurpose Passenger Vehicle; any vehicle with a seating capacity of ten or fewer, including the driver, which is built on a truck chassis, or with special features for occasional off-road use.

MRO: Medical Review Officer; a licensed physician with knowledge of substance abuse disorders required by 49 CFR 40 to receive and evaluate laboratory results generated by a carrier's drug testing program.

MVR: Motor Vehicle Record of the driver; also known as *driving history*.

NAPT: National Association for Pupil Transportation, a membership organization comprising individuals and organizations representing all facets of school transportation.

NASDPTS: National Association of State Directors of Pupil Transportation Services, a membership organization comprising primarily state officials responsible for pupil transportation.

National school bus yellow: The color defined in the publication "National School Bus Color Standard" SBMTC-008.

NDR: National Driver Registry.

Neutral safety switch: A device which prevents the bus from starting unless the transmission is in neutral gear or the clutch is depressed.

NGV: Natural Gas Vehicle.

NHTSA: National Highway Traffic Safety Administration, an agency of the U.S. Department of Transportation.

NIST: National Institute of Standards and Technology.

Nominal dimension: A dimension which exists in name only (e.g. 5/8" plywood which is actually 19/32" thick, but is 5/8" nominal thickness.) The variation between the actual dimension and the nominal dimension is the result of manufacturing practices and tolerances.

Non-conforming van: A vehicle smaller than a bus, designed to carry seven to ten passengers and used to transport students, that does not meet FMVSS for school buses.

NPRM: Notice of Proposed Rulemaking; a notice published in the *Federal Register* by a federal agency of a proposed change in regulation.

NSC: National Safety Council.

NSTA: National School Transportation Association, a membership organization comprising primarily school transportation contractor companies.

NTSB: National Transportation Safety Board, an independent federal agency authorized by Congress to investigate accidents and to issue safety recommendations.

OCR: Office of Civil Rights, an agency of the U.S. Department of Education.

OEM: Original Equipment Manufacturer.

On-board monitoring system: Computerized tracking of driver and vehicle performance, including speed, fuel consumption, etc.

Operating costs: All costs associated with running the transportation system, which are distinct from capital costs.

Operator: The carrier who is responsible for running the transportation system, regardless of ownership of the vehicle.

OSEP: Office of Special Education Programs, an agency of the U.S. Department of Education.

OSERS: Office of Special Education and Rehabilitative Services, an agency of the U.S. Department of Education.

OSHA: Occupational Safety and Health Administration, an agency of the U.S. Department of Labor.

OTETA: The Omnibus Transportation Employees Testing Act of 1991, requiring drivers holding CDLs to participate in a drug and alcohol testing program.

Out of Service: The removal of a school bus from passenger service due to a defective condition.

Overall vehicle width: The nominal design dimension of the widest part of the vehicle, exclusive of signal lamps, marker lamps, outside rearview mirrors, flexible fender extensions and mud flaps, determined with the doors and windows closed and the wheels in the straight-ahead position.

Overhang: The distance from the center of the rear axle to the rearmost end of the body or from the center of the front axle to the forward edge of the front bumper.

- P. A. system:** A public address system which allows the driver of a bus to communicate with persons inside and/or outside the bus through a speaker installed on the inside and/or outside of the bus; also known as *external loudspeaker*.
- Parallel restraint system:** A system in which the occupant restraint lap belt anchors directly to the floor track or plates, and is independent of the wheelchair/mobility aid securement system.
- Paratransit:** Public transit service which is more flexible than a fixed-route system, commonly providing special service for elderly and disabled passengers.
- Part B:** Refers to the section of the EHA applicable to special education and related services for children with disabilities and to the implementing regulations at 34 CFR 300.
- Part H:** Refers to the section of the IDEA related to early intervention services for infants and toddlers and to the implementing regulations at 34 CFR 303.
- Particulate trap:** A device on diesel buses to clean the exhaust of particulate matter.
- Passenger miles:** The total number of miles traveled by the aggregate number of passengers on a vehicle (e.g. ten students traveling ten miles on one bus equals 100 passenger miles.)
- P.L.94-142:** (See *EHA*.)
- Postural support:** A seat, belt or other component used to support a child with disabilities in a desired position but not designed or intended to provide occupant restraint in a crash; also known as *positioning device*.
- Power base:** A powered, wheeled platform used to mount a seating device for carrying an individual with a disability; usually characterized by smaller diameter tires.
- Power cut-off switch:** A device that cancels all power from the vehicle batteries.
- Power lift:** A mechanized platform designed to provide access to a vehicle for an occupied mobility aid/wheel chair; also known as a *wheelchair lift*.
- Positive-locking:** A design feature of the mobility aid securement and occupant restraint system where the attachment and anchoring hardware cannot be inadvertently released or disengaged once properly installed.
- Post-trip interior inspection:** A check of the interior of the bus by the driver at the end of the run to ensure that no children or student belongings have been left behind.
- Powertrain:** The group of components used to transmit engine power to the wheels; includes transmission, universal joints, driveshaft, drive axles and gears; also known as *drivetrain*.
- Pre school:** Refers to a child between the ages of three and five years who is not yet in kindergarten or to a program serving children in that age range.
- Pre-trip inspection:** A systematic inspection of the bus by the driver before every trip or shift to ensure that the bus is in safe operating condition. The same procedure performed after the trip/shift is the *post-trip inspection*.
- Privatization:** The process of transferring the operation of public services from the public agencies to private companies or nonprofit organizations; also known as *contracting* or *outsourcing*.

Pusher: A school bus in which the engine is mounted in the rear of the vehicle; also known as *rear-engine bus*.

Pushout window: A bus window that is hinged at the top or front to enable the window to be swung upward or outward relative to the side of the bus and to provide a means of emergency egress from the bus; also known as *emergency window*.

Railroad crossing: The intersection of a highway, street or roadway and railroad tracks; also known as *grade crossing*.

Ramp: An inclined plane for use between the ground and the floor of the vehicle to permit access by persons in wheelchairs/mobility aids.

Reflective: Refers to the property of materials that cause them, when they are illuminated, to reflect the light to some extent.

Related services: Transportation and other supportive services that are required to assist a child with a disability to benefit from special education.

Remanufactured: Refers to a vehicle component that has been structurally restored.

RESNA: Rehabilitation Engineering Society of North America, an organization engaged in research and development of assistive technology for persons with disabilities.

Restraining barrier: An assembly similar to a seat back located immediately in front of a single school bus passenger seat or row of seats to provide crash protection in accordance with FMVSS No. 222; also known as *barrier*, *crash barrier*, and *seat barrier*.

Restraint system: A generic term for one or more devices intended to secure and protect a passenger with or without a mobility aid in a vehicle, including lap belts, lap/shoulder belts, child safety seats, safety vests, etc.

Restraint/securement system: (See *securement and restraint system*.)

Retractor, automatic-locking: A retractor incorporating adjustment by means of a positive self-locking mechanism which is capable of withstanding restraint forces.

Retractor, emergency-locking: A retractor that incorporates adjustment by means of a locking mechanism that is activated by vehicle acceleration, webbing movement relative to the vehicle, or automatic action during an emergency, and that is capable of withstanding restraint forces.

Retroreflective: Refers to material that is designed to return illumination of the material directly or generally back to the source of illumination.

RFP: Request For Proposals; an invitation to submit a contract proposal, less restrictive than an invitation to bid on a contract.

Ridership: The number of passengers using a transportation system during a given time period.

Right: Right position is determined from the normal driving position as seated in the driver's seat looking in the forward direction of travel.

Rim: The part of the wheel on which the tire is mounted and supported.

Risk management: Practices and procedures designed to protect against losses from accidents, passenger and worker injuries, vehicle damage and other losses, and to reduce insurance costs.

Rolling stock: The vehicles in a transportation system.

Roof hatch: (See *emergency roof exit*.)

Route: A designated course regularly traveled by a school bus to pick up students and take them to school, or to deliver students from school to their homes or designated bus stops.

Route miles: The total number of miles in one or more routes in the system.

Route sheet: A list of all the designated stops on a route.

Run: A complete trip on a route. (To illustrate the difference between a run and a route: it is possible to have six daily runs on the same route, i.e., one high school, one middle school, and one elementary run both morning and afternoon.)

Running gear: The wheels, axles, springs, frames and other carrying parts of the vehicle.

SAE: Society of Automotive Engineers, the leading standards-writing organization for the automotive industry.

SAP: Substance Abuse Professional; a licensed physician, psychologist, social worker or alcohol and drug counselor who is required to evaluate any employee who violates a carrier's drug and alcohol testing program.

Safety vest/harness: An upper torso restraint that supports and secures a child by attachment to the vehicle seat.

Safety patrol: Students whose duties may include acting as crossing guards and safety assistants.

Safety training: Educational programs provided for students to teach proper behavior while waiting for, riding in, boarding or leaving school buses; also known as *ridership programs*.

SBMTC: School Bus Manufacturers Technical Council; formerly the School Bus Manufacturers Institute (SBMI); a membership organization within NASDPTS which serves as a technical advisor regarding school buses.

School: An educational institution for children at the pre-primary, primary, elementary, or secondary level, including nursery schools and Head Start programs, but not including day care programs.

School bus equipment: Equipment designed primarily as a system, part or component of a school bus, or any similar part or component manufactured or sold for replacement or as an accessory or addition to a school bus.

School bus stop: An area on the street or highway designated by school officials for picking up and discharging students.

School trip: (See *activity trip*.)

School vehicle: Any vehicle owned, leased, contracted to or operated by a school or school district and regularly used to transport students to and from school or school-related activities. Includes school buses, activity buses, vans and passenger cars, but does not include transit or charter buses.

Scooter: A motorized mobility aid with three wheels, handle bar or tiller and a swiveling seat.

SEA: State Education Agency.

Seat: A device designed and installed to provide seating accommodations.

Activity seat: A seat designed for passenger comfort with contoured seats and backs with the result that passengers' positions are distinctly separate; characterized by fixed seat backs; may have arm rests and head rests; can be manufactured to meet FMVSS No. 222.

Bench seat: A seat designed to accommodate more than one passenger with no apparent partitioning between positions, which is characterized by fixed legs and a fixed back (e.g., the standard school bus seat which meets FMVSS No. 222.)

Davenport seat: A bench seat that extends from side wall to side wall at the rearmost seating position in the bus; not permitted in school buses.

Flip seat: A school bus bench seat designed so that the cushion flips up when the seat is not occupied, similar to a theater seat; used to provide aisle clearance when a passenger seat is located adjacent to a side emergency door, as required by FMVSS No. 217.

Integrated child safety seat: A child safety seat meeting the requirements of FMVSS No. 213 which is built into and thus an integral part of a bench seat.

Jump seat: A seat designed to fold down to provide supplemental seating in a bus (e.g. in the aisle, in front of the door or along the side wall); not permitted in school buses.

Reclining seat: An activity seat with a reclining seat back; not permitted in school buses.

Seat belt: (See *seat restraints*.)

Seating capacity: The number of designated seating positions provided in a vehicle, including the driver's position. In determining seating capacity, each wheelchair securement location shall be counted as four (4) designated seating positions.

Designed seating capacity: The theoretical passenger capacity that a vehicle would have if it were constructed with the maximum number of seating positions according to standard seating plans; also known as *manufacturer's seating capacity*.

Reduced capacity: The capacity that is achieved when one or more seats are removed from the standard design during or after manufacture of the vehicle.

Seating position: The space on a school bus bench seat designated for one student. The number of such positions per seat is determined by dividing the width of the seat by 15" and rounding to the nearest whole number, as described in FMVSS No. 222.

Seating reference point: The manufacturer's design point, with coordinates relative to the vehicle structure, which establishes the rearmost normal driving or riding position of each designated seating position and simulates the position of the pivot center of the human torso and thigh.

Seat restraints: A passenger restraint system incorporating lap belts or lap/shoulder belts and meeting the requirements of FMVSS Nos. 209 and 210.

Section 402: Section of 23 CFR that authorizes grant funds for highway safety projects.

Section 504: Section of the Rehabilitation Act of 1973, PL 93-112, which prohibits discrimination against individuals with disabilities by any recipient of federal funding.

Securement points: Locations on the base or seat frame of the wheelchair/mobility aid where the securement system should be attached.

Securement system: The means of securing a mobile seating device to a vehicle in accordance with FMVSS No. 222, including all necessary buckles, anchors, webbing/straps and other fasteners.

Securement and restraint system: The total system which secures and restrains both a wheelchair/mobility aid and its occupant; also known as *WTORS*.

Self-insured: Refers to a company or school district which provides reserved funds against claims or losses.

Sensor: An electronic device installed on a school bus for the purpose of detecting animate objects in the loading zone; also known as *object detection system*.

Seizure: A reaction to an electrical discharge in the brain, resulting in symptoms which can range from a blank stare of a few seconds to full convulsions.

Shuttle: A trip run back and forth over a short route (e.g. between two schools.)

Skid plate: Stout metal plate attached to the underside of a vehicle to protect the oil pan, transmission, step well or fuel tank from scraping on rocks, curbs and road surface.

Slack adjuster: Adjustable device connected to the brake chamber pushrod used to make up for brake shoe wear.

SOS lights: Stop on Signal lights. (*See alternately flashing signal lights.*)

SOWAT: The Subcommittee on Wheelchairs and Transportation, a group acting under the auspices of RESNA to develop transportable wheelchair crashworthiness standards.

Special education: Specially designed instruction to meet the unique needs of a child with disabilities.

Specially equipped school bus: Any school bus designed, equipped or modified to accommodate students with special needs.

Split-brake system: A service brake system with two separate hydraulic circuits which, upon failure of either, retains full or partial braking ability.

Stanchion: An upright post or bar, usually installed from floor to ceiling in a bus, that provides support for other structural members and/or provides a hand-hold for passengers.

State: As used in this document, "state" shall refer to any of the 50 states and commonwealths and any United States territory, possession, or federal agency (e.g., the General Services Administration or the Department of Defense) that may consider, follow or adopt part or all of the specifications and procedures contained herein for school buses and operations.

State director: The chief government administrator in charge of a state's pupil transportation program and responsible for oversight of regulatory functions.

Stop arm: A device in the form of a red octagon extending outward from the side of a school bus to signal that the bus has stopped to load or unload passengers and meeting FMVSS No. 131; also known as *stop semaphore* and *stop signal arm*.

Stopping distance: Braking distance plus reaction distance.

Braking distance: The distance a vehicle travels between the time the brakes are applied and the time forward motion ceases.

Reaction distance: Distance a vehicle travels during the time it takes for a driver to recognize the need to stop and to apply the brakes.

Strobe light: A bright short duration light that flashes as a result of an electronic discharge of electricity through a gas.

Stroller: A light weight folding mobility aid.

Student: Any child who attends a school, as previously defined.

Student rides: The number of students transported in a given system multiplied by the number of one-way trips in a school bus. (For example, a school district that transports 1000 students provides 2000 student rides daily or 360,000 student rides to and from school annually, assuming 180 school days. To determine the total number of student rides annually, the district would add the actual or estimated number of students transported on activity trips [times 2] to the figure above.)

Substitute driver: A driver who is not assigned to a regular route but is employed to provide immediate coverage when necessary due to driver absences or emergencies; also known as *spare driver* and *extraboard driver*.

Surrogate wheelchair: A wheelchair device which is subjected to impact tests to test securement and restraint systems.

Suspension system: The components of the vehicle that transmit the load of the vehicle's weight from the chassis framework to the ground, including the springs, axles, wheels, tires and related connecting components.

TDD: Telecommunication devices for the deaf.

Temperature control system: The means of heating or cooling the interior of the vehicle.

Tether: An upper anchor strap used in addition to a seat belt to hold certain types of restraint devices in place.

Tie-down system: (See *securement system*.)

Tire: The continuous solid or pneumatic rubber elastomeric cushion encircling a wheel intended for contact with the road.

Bias ply: A pneumatic tire in which the ply cords extending to the beads are laid at alternate angles substantially less than 90 degrees to the centerline of the tire.

Low profile: A tire that has a section height that is less than 85 percent of its nominal section width (e.g., a tire with an aspect ratio of less than 0.85.)

Radial: A pneumatic tire in which the ply cords which extend to the beads are laid substantially at 90 degrees to the centerline of the tread.

Retread: A worn tire casing to which tread rubber has been affixed to extend the usable life of the tire; also known as *re-capped* or *retreaded tire*.

Siped: A tire which has been scored or cut perpendicular to the direction of rotation (across the tread) to improve traction.

Snow: A tire with an obvious aggressive or lug type tread across the entire width which is designed to be self-cleaning.

Studded: A tire to which metal protrusions have been added to improve traction.

Tire cords: The strands forming the reinforcement structure in a tire.

To-and-from school: Transportation from home to school and from school to home; also transportation from school to school or from school to job training site.

Tour: Transportation of a group on a longer trip, usually by *charter bus* (e.g. senior class trip to Washington.)

Tow hooks: Attachments on the chassis frame for use in towing the vehicle backwards or forwards; also known as *tow eyes*.

Track seating: A seating system in which seating units, including mobility aids, are secured to the vehicle structure by attaching them to tracks on the vehicle floor.

Traffic lights: Traffic signals which control the flow of traffic at intersections.

Transverse: Perpendicular to the longitudinal centerline of the vehicle (i.e. from side to side.)

Trip: The transportation of students from school to any destination, followed by a return trip back to school. The two together make a *round trip*.

Tripper service: Regularly scheduled mass transit service which is open to the public, and which is designed or modified to accommodate the needs of school students and personnel, using various fare collections or subsidy systems. Must be part of the regular route service as indicated in published route schedules.

Turbocharger: a device which uses the pressure of exhaust gases to drive a turbine that, in turn, pressurizes air normally drawn into the engine's chambers.

Turnkey: Partial privatization in which a school district hires a company to supply drivers, maintenance management and/or vehicles; also known as *management contract*.

Two-way radio: Electronic communication system which uses a designated airway for transmission between a bus and a base station.

UCRA: Universal child restraint anchorage, a standardized means of installing child restraint systems in vehicles that is independent of the seat belt system. UCRA's will be required in all new motor vehicles under 10,000 pounds, including school buses, as of September 2002.

UMTA: Urban Mass Transit Administration, predecessor to FTA.

Unload: To discharge passengers from a school bus.

Unloaded vehicle weight: the weight of vehicle with maximum capacity of all fluids necessary for operation, but without cargo or occupants or accessories that are ordinarily removed from the vehicle when they are not in use.

Universal precautions: Method of infection control designed to protect the individual from exposure to disease, which requires that all bodily fluids and secretions are treated as though they were infectious.

UST: Underground storage tank.

Vaporlock: Boiling or vaporization of fuel in the lines from excessive heat, which interferes with liquid fuel movement and in some cases stops the flow.

Vehicle miles: The aggregate number of miles a vehicle travels in a given period.

Video system: A means of monitoring student behavior in a school bus. The system includes one or more video cameras to tape activity. Camera housing units mounted in each bus appear to hold a camera, whether or not one is actually in place; also known as *surveillance*.

VIN: Vehicle Identification Number; a series of Arabic numbers and Roman letters which is assigned to a motor vehicle for identification purposes.

Viscosity: A measure of internal resistance to flow or motion offered by a fluid lubricant.

Walking distance: The maximum distance a student can be required to walk to school before transportation must be provided.

Weather emergencies: Weather conditions that require a deviation from normal transportation procedures (e.g., flooding, snowstorm.)

Weight distribution: The distribution proportion of the vehicle load divided between the front and rear axles.

Wheel: A rotating load-carrying member between the tire and the hub, usually consisting of two major parts, the rim and the wheel disc, which may be integral, permanently attached or detachable.

Ball seat nut mounting: A wheel mounting system wherein the wheel centering is provided by the wheel mounting studs and the ball seat nuts which, when properly tightened, assure the centering alignment of the wheel.

Disc: The part of the wheel which is the supporting member between the hub and the rim.

Disc wheel: A permanent combination of a rim and wheel disc.

Hub: The rotating outer member of the axles assembly which provides for wheel disc mounting.

Locking ring: A removable, split rim ring that holds the rim flange in place on a multi-piece rim.

Piloted hub mounting: A wheel mounting system wherein the wheel centering is provided by a close fit between the wheel disc and the hub.

Rim: The part of the wheel on which the tire is mounted and supported.

Spoke wheel: A rotating member which provides for mounting and support of one or two demountable rims; also known as *wheel for demountable rim*.

Wheelbase: The distance between the front and rear axles.

Wheelchair: A seating system comprising at least a frame, seat and wheels for the support and mobility of a person with physical disabilities; also known as *mobile seating device*.

Wheelchair lift: (See power lift.)

ZEB: Zero-emissions bus.

ZEV: Zero-emissions vehicle.

APPENDIX B
School Bus
Chassis and
Body

APPENDIX B

School Bus Chassis And Body

National School Bus Yellow

The color known as National School Bus Yellow is specified and described in the School Bus Manufacturers Technical Council publication "National School Bus Yellow Color Standard" (SBMTC-008).

Bus Body Heating System Test

1. Scope

This procedure, limited to liquid coolant systems, establishes uniform cold weather bus vehicle heating system test procedures for all vehicles designed to transport ten (10) or more passengers. Required test equipment, facilities and definitions are included. Defrosting and defogging procedures and requirements are established by SAE J381 and SAE J382, which are hereby included by reference.

1.1 Purpose

This procedure is designed to provide bus manufacturers with a cost effective, standardized test method to provide relative approximations of cold weather interior temperatures.

2. Definitions

- 2.1 Heat Exchanger System** - Means will exist for providing heating and windshield defrosting, and defogging, capability in a bus. The system shall consist of an integral assembly, or assemblies, having a core assembly or assemblies, blower(s), fan(s), and necessary duct systems and controls to provide heating, defrosting and defogging functions. If the bus body structure makes up some portion of the duct system this structure or a simulation of this structure must be included as part of the system.
- 2.2 Heat Exchanger Core Assembly** - The core shall consist of a liquid to air heat transfer surface(s), liquid inlet and discharge tubes or pipes.
- 2.3 Heat Exchanger-Defroster Blower** - An air moving device(s) compatible with energies available on the bus body.
- 2.4 Coolant** - A 50-50 solution of commercially available glycol antifreeze and commercial purity water. Commercial purity water is defined as that obtained from a municipal water supply system.
- 2.5 Heat Exchanger-Defroster Duct System** - Passages that conduct inlet and discharge air throughout the heater system. The discharge outlet louvers shall be included as part of the system.
- 2.6 Heater Test Vehicle** - The completed bus as designed by the manufacturer with, or without, a chassis, engine and driver train, including the defined heat exchanger system. If the vehicle is without a chassis, it shall be placed on the test site in such a way that the finished floor of the body is at a height, from the test site floor, equal to its installed height when on a chassis, and all holes and other openings normally filled when installed on a chassis will be plugged.

2.7 Heat Transfer - The transfer of heat from liquid to air is directly proportional to the difference between the temperatures of the liquid and air entering the transfer system, for a given rate of liquid and air flow measured in pounds per minute, and that heat removed from liquid is equal to heat given to air.

3. Equipment

3.1 Test Site - A suitable location capable of maintaining an average ambient temperature not to exceed 25°F (-3.9°C) for the duration of the test period. The maximum air velocity across the vehicle shall be 5 mph (8kph).

3.2 Coolant Supply - A closed loop system, independent of any engine/drivetrain system, capable of delivering a 50-50 (by volume) solution of antifreeze-water, as defined in 2.4, at 150°±5° (65.5°±1.7°C) above the test site ambient temperature, and 50 lbs (22.7 kg) per minute flow. The coolant supply device shall be equipped with an outlet diverter valve to circulate coolant within the device during its warm-up period. The valve will then permit switching the coolant supply to the bus heat exchanger system at the start of the test.

3.3 Power Equipment Supply - A source capable of providing the required test voltage and current for the heater system.

3.4 Heat Exchange Units - The heat exchangers used shall be labeled as specified by the School Bus Manufacturer's Technical Council No. 001 (Revised 4/94). The test rating of each unit, and quantity used, shall be recorded.

4. Instrumentation

4.1 Air Temperature

4.1.1 Interior - Recommended air temperature measuring instrumentation are thermocouples or RTD's. Thermometers are not recommended because of their slow response to rapid temperature changes. Measuring instrumentation shall be placed on alternate seat rows beginning 39 in ± 5 in (99 cm ± 13 cm) from the rear of the body, at 36 inches ± 2 inches (91 cm ± 5 cm) from the finished floor of the body, and on the longitudinal centerline of the body.

4.1.2 Ambient - A set of four (4) of electrically averaged temperature measuring devices shall be placed 18 inches ± 5 inches (46 cm ± 13 cm) from the nearest body surface, 96 ± 5 in (243 cm ± 13 cm) above the floor of test site. One measuring device shall be placed at each of the following locations:

- 1) Midline of body forward of windshield;
- 2) Midline of body aft of the rear surface; and
- 3) Midway between the axles on the right and left sides of the body.

4.1.3 Driver - Measuring devices shall be placed at appropriate locations to measure ankle, knee, and breath level temperatures with the driver's seat in rearmost, lowest and body center-most position.

- (1) **Ankle Level** - Place a minimum of four (4) electrically averaged temperature measuring devices at the corners of a 10 X 10 in (25 X 25 cm) square area, the rearmost edge of which begins 8 inches (20 cm) forward of the front edge of, and centered on, the seat cushion. The devices shall be located 3 inches ± 0.5 in (7.5 cm ± 1.3 cm) above floor surface.
- (2) **Knee Level** - Place a minimum of one measuring device at the height of the front top edge of the seat cushion and on the centerline of the seat. This measurement shall be 4 in ± 1 in (10 cm ± 2.5 cm) forward of the extreme front edge of the seat cushion and parallel to the floor.
- (3) **Breath Level** - Place a minimum of one measuring device 42 in ± 2 in (107 cm ± 5 cm) above the floor and 10 in ± 2 in (25 cm ± 5 cm) forward of the seat back. The forward dimension shall be measured from the upper edge of the seat back and parallel to the floor.

4.1.4 (Optional) Heat Exchanger Inlet and Outlet Temperature - A minimum of four (4) electrically averaged temperature measuring devices shall be used to measure the inlet air temperature of each heat exchange unit. Additionally, a minimum of four (4) electronically averaged temperature measuring devices shall be used to measure the outlet air temperature of each heat exchange unit. These sensors shall be placed no closer than 2.0 inches (5.1 cm) from the face of any heater core, to prevent any incidence of radiant heat transfer. Outlet sensors shall be distributed throughout the outlet air stream(s) 1.0 inches +/- .25 inches (2.5 cm +/- .6 cm) from the outlet aperture(s) of the unit heater.

4.1.5 (Optional) Defrost Air Temperature - The temperature of the defrost air shall be measured at a point in the defroster outlet(s) that is in the main air flow and which is at least one (1) inch (2.54 cm) below (upstream of) the plane of the defroster outlet opening. At least one temperature measurement shall be made in each outlet unit. The interior surface temperature(s) of the windshield shall be measured at a point located on the vertical and horizontal centerline(s) of the windshield.

4.1.6 (Optional) Entrance Area Temperature - The temperature of the vehicle entrance area shall be measured by two (2) sets of three (3) each electrically averaged temperature measuring devices. One set of three devices shall be placed one (1) inches (2.54 cm) above the lowest tread of the entrance step, equally spaced on the longitudinal centerline of the tread. The second set of devices shall be placed on the next horizontal surface above the lowest entrance step, 4 inches (10.2 cm) from the outboard edge of that surface, spaced identically to the first set of sensors, and placed parallel with the outboard edge of the surface being measured.

4.2 Coolant Temperature - The temperature entering and leaving the heat exchanger/defroster system shall be measured as close to the entrance and exit points of the bus body as possible with an immersion thermocouple or RTD device which can be read within +/- 0.5°F (+/- 0.3°C).

4.3 Coolant Flow - The quantity of coolant flowing shall be measured by means of a calibrated flow meter or weighing tank to an accuracy of at least 2 percent of setpoint.

4.4 Coolant Pressure - The coolant differential pressure shall be measured by suitable connection as close as possible to the inlet and outlet of the heat exchanger/defrosting system. Pressure may be read as inlet and outlet pressure and the differential calculated, or read directly as PSID. Pressure readings shall be made with the use of gauges, manometers or transducers capable of reading within +/- 0.1 psi (689.5 Pa), accurate to +/- 0.5% of full scale.

4.5 Additional Instrumentation - Additional instrumentation required for vehicle heat exchanger system testing is a voltmeter and a shunt type ammeter to read the voltage and current of the complete system. The ammeter and voltmeter shall be capable of an accuracy of +/- 1 percent of the reading.

5. Test Procedures - Install the heater test vehicle on the test site. Testing shall be conducted in such a way as to prevent the effects of solar heating. At an outdoor test site, testing shall commence and data shall be recorded during the hours following sunset and prior to sunrise, regardless of cloud cover or facility roof. Instrumentation is required to obtain the following readings:

- (a) Vehicle interior (4.1.1).
- (b) Inlet coolant temperature, at entrance to the bus body (4.2).
- (c) Discharge coolant temperature, at exit from the bus body (4.2).
- (d) Voltage and current at main bus bar connection of driver's control panel.
- (e) Ambient temperature (4.1.2).
- (f) Rate of coolant flow (4.3).
- (g) Coolant flow pressure (4.4).
- (h) Elapsed time (stop watch).
- (i) Driver's station temperatures (4.1.3).

- (j) (Optional) Heat Exchanger Inlet and Outlet Temperatures (4.1.4).
- (k) (Optional) Defrost Air Temperature (4.1.5)
- (l) (Optional) Entrance Area Temperature (4.1.6)

Soak the test vehicle, with doors open, for the length of time necessary to stabilize the interior temperature for a 30 minute period as recorded by the vehicle interior temperature measuring devices, and the coolant temperature as measured by the inlet and outlet coolant temperature measuring devices, at the test site temperature, +/- 5°F (+/- 2.5°C), not to exceed 25°F (-3.9°C). Warm up the coolant device to the test temperature immediately prior to the start of the test. Use the coolant supply outlet diverter valve to prevent heated coolant from entering the bus heating system prior to the start of the test. At this time, set the heater controls and all fan controls at maximum, close all doors. A maximum of two windows may be left open a total of one (1) inch (2.5 cm) each. A maximum of two occupants may be in the body during the test period. Record all instrumentation readings at five minute intervals for a period of 1 hour. Recording time shall begin with the initial introduction of heated coolant from the independent coolant supply. The electrical system shall be operated at a maximum of 115% of nominal system voltage +/- 0.2 volts, for example: 13.8 VDC +/- 0.2 volts for a 12 VDC system, and the heat exchanger system shall be wired with the normal vehicle wiring.

Optional - Additional flow rates and/or coolant temperatures may also be used to generate supplementary data. Test procedure five (5) shall be repeated for each additional flow rate and/or coolant temperature.

6. Computations

6.1 Chart and Computations - Customary Units-Data shall be recorded on Chart 6.1 or equivalent. Temperature data shall be recorded at the actual temperatures occurring at the time of testing. Air temperature data shall then be adjusted to a 0°F base prior to the construction of graphs. This data reduction shall be directly proportional to the difference between the actual ambient temperature, at the time of test, and 0°F i.e., actual ambient of 18°F shall result in a reduction of all air temperatures by 18°F, actual ambient temperature of -8°F shall result in an increase of all air temperatures by 8°F. Temperature data shall be presented in graph form as well as tabular form. One graph shall be constructed for the body interior air temperatures (4.1.1) wherein the recording intervals shall be the X-axis and the °F the Y-axis. A separate graph shall be constructed for the driver's temperatures (4.1.3) using the same units for the axes. Optional temperature data (4.1.4, 4.1.5, 4.1.6) may be similarly graphed separate from the interior data.

6.1.1 Optional Computations BTU/Hr. Coolant

1. Flow of Coolant (Ww)-lb/min-measured to +/- 2 percent.
2. Temperature of Coolant into System (T-in)- °F -measured.
3. Temperature of Coolant out of System (T-out)- °F -measured.
4. Heat Removed From Coolant (Qw)-Btu/h-calculated:

$$Qw = CpWw(T-in - T-out) X 60$$

$$Cp = \text{Specific Heat of Coolant - Given as } 0.85 \times 1.0018$$

$$\text{BTU/lb/°F} = .8515$$

$$Ww = \text{No. 1}$$

$$T-in = \text{No. 2}$$

$$T-out = \text{No. 3}$$

6.2 Chart and Computations - Metric Units - Data shall be recorded on Chart 6.2 or equivalent. Temperature data shall be recorded at the actual temperatures occurring at the time of testing. Air temperature data shall then be adjusted to a -18°C base prior to the construction of graphs. This data reduction shall be directly proportional to the difference between the actual ambient temperature, at the time of test, and -18°C i.e., actual ambient of -7.8°C shall result in a reduction of all air temperatures by 10.2°C, actual ambient temperature of -22.2°C shall result in an increase of all air temperatures by 4.2°C. Temperature data shall be presented

in graph form as well as tabular form. One graph shall be constructed for the body interior air temperatures (4.1.1) wherein the recording intervals shall be the X-axis and °C the Y-axis. A separate graph shall be constructed for the driver's temperatures (4.1.3) using the same units for the axes. Optional temperature data (4.1.4, 4.1.5, 4.1.6) may be similarly graphed separate from the interior data.

6.2.1 Optional Computations BTU/Hr - Coolant

1. Flow of Coolant (Ww) - kg/min - measured to +/-2%.
2. Temperature of Coolant into System (T-in) - °C - measured.
3. Temperature of Coolant out of System (T-out) - °C -measured.
4. Heat Removed From Coolant Flow (Qw) - J/h - calculated:
 $Qw = CpWw (T-in - T-out) X (60)$
 Cp =Specific Heat of Coolant - Given as (0.85 x 4187j)/(kg/c)
 Ww =No. 1
 T-in =No. 2
 T-out =No. 3.

Chart 6.1-Optional Measurements

Readings/Calculations	0	5	10	15	20	25	30	35	40	45	50	55	60
T11-Windshield CL Left- °F													
T12-Windshield CL Right- °F													
T13-Defrost Outlet Left- °F													
T14-Defrost Outlet Right °F													
T15-Heater-Inlet °F													
T15-Heater-Outlet °F													
T16-Heater-Inlet °F													
T16-Heater-Outlet °F													
T17-Heater-Inlet °F													
T17-Heater-Outlet °F													
T18-Heater-Inlet °F													
T18-Heater-Outlet °F													
T19-1st Entrance Step													
T20-2nd Entrance Step													
Heat Transfer-BTU/Hr-coolant													

Chart 6.2-Optional Measurements

Readings/Calculations	0	5	10	15	20	25	30	35	40	45	50	55	60
T11-Windshield CL Left- °C													
T12-Windshield CL Right- °C													
T13-Defrost Outlet Left- °C													
T14-Defrost Outlet Right °C													
T15-Heater-Inlet °C													
T15-Heater-Outlet °C													
T16-Heater-Inlet °C													
T16-Heater-Outlet °C													
T17-Heater-Inlet °C													
T17-Heater-Outlet °C													
T18-Heater-Inlet °C													
T18-Heater-Outlet °C													
T19-1st Entrance Step													
T20-2nd Entrance Step													
Heat Transfer-1/Hr-coolant													

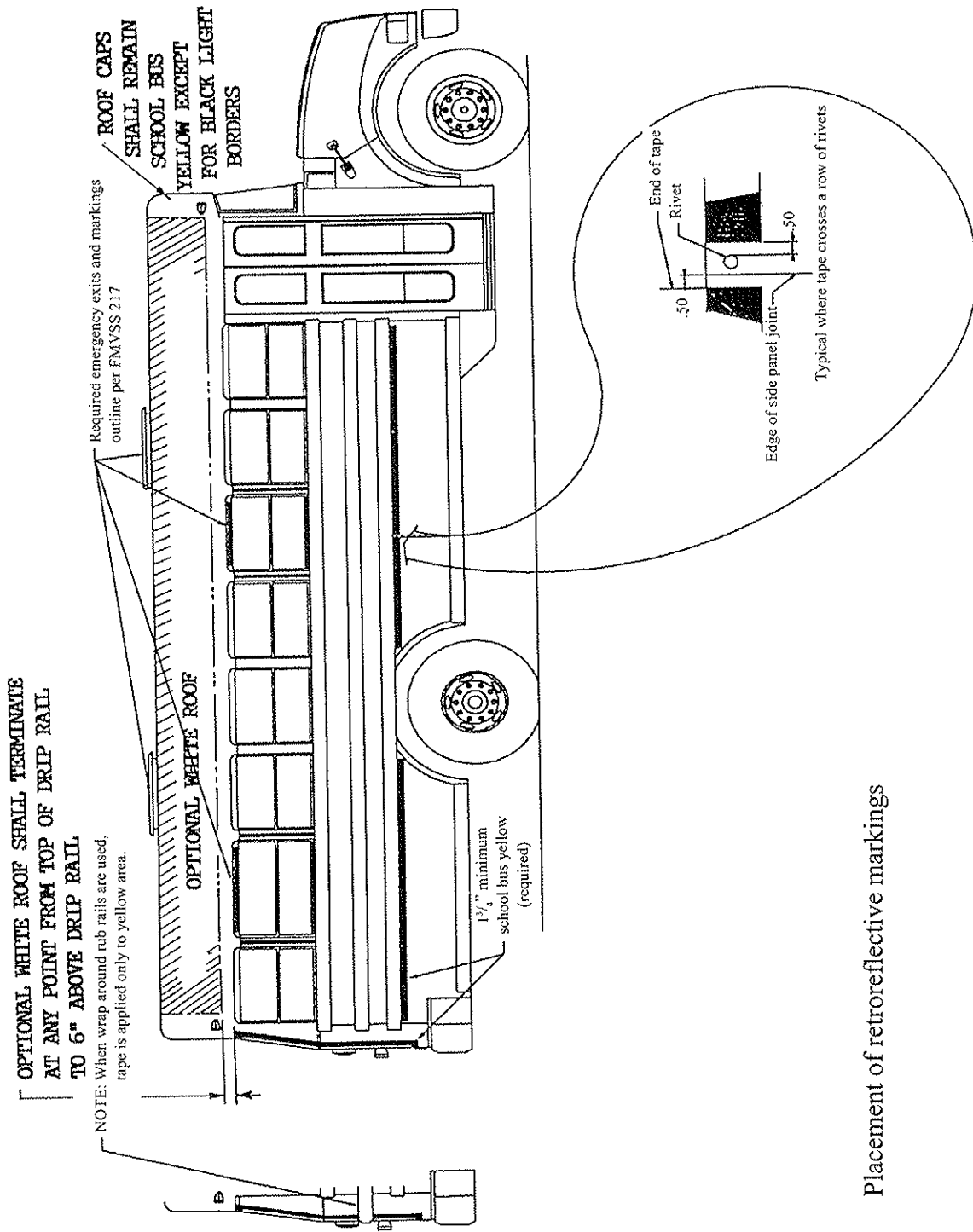

Placement of retroreflective markings

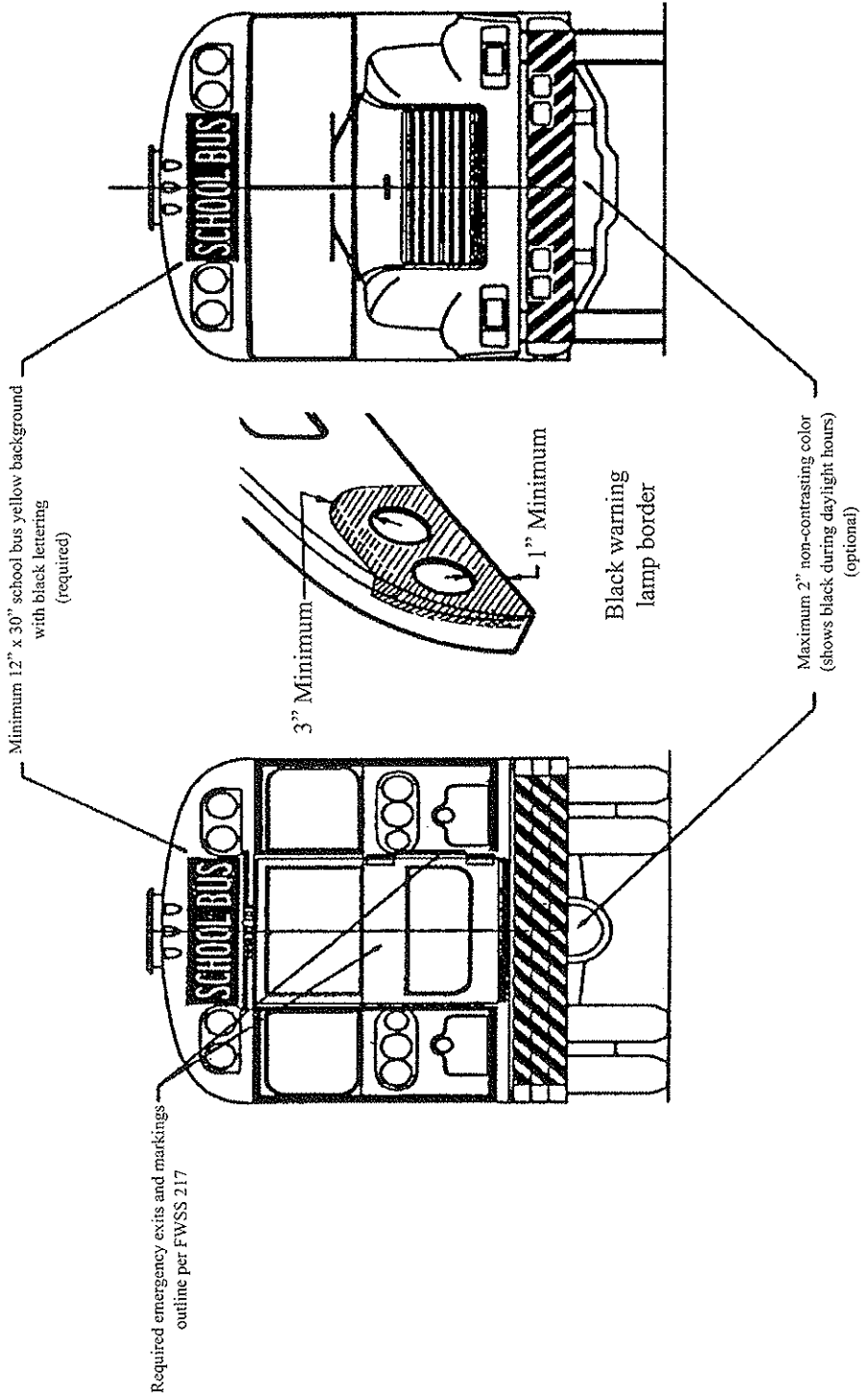

Placement of retroreflective markings

NOISE TEST PROCEDURE

- A. The vehicle is located so that no other vehicle or signboard, building, hill or other large reflecting surface is within 15.2 m (50 feet) of the occupant's seating position.
- B. All vehicle doors, windows and ventilators are closed.
- C. All power-operated accessories are turned off.
- D. The driver is in the normal seated driving position and the person conducting the test is the only other person in the vehicle.
- E. A sound level meter is used that is set at the "A-weighting fast" meter response and meets the requirements of:
 - 1. The American National Standards Institute, Standard ANSI S1.4-1971: "Specifications for Sound Level Meters," for Type 1 Meters; or
 - 2. The International Electrotechnical Commission (IEC), Publication No. 179 (1973): "Precision Sound Level Meters."
- F. The microphone is located so that it points vertically upward 6 inches to the right and directly in line with and on the same plane as the occupant's ear, adjacent to the primary noise source.
- G. If the motor vehicle's engine radiator fan drive is equipped with a clutch or similar device that automatically either reduces the rotational speed of the fan or completely disengages the fan from its power source in response to reduced engine cooling loads, the vehicle may be parked before testing with its engine running at high idle or any other speed the operator chooses for sufficient time, but not more than 10 minutes, to permit the engine radiator fan to automatically disengage.
- H. With the vehicle's transmission in neutral gear, the engine is accelerated to:
 - 1. Its maximum governed speed, if it is equipped with an engine governor; or
 - 2. Its speed at its maximum rated horsepower, if it is not equipped with an engine governor, and the engine is stabilized at that speed.
- I. The A-weighted sound level reading on the sound level meter for the stabilized engine speed condition referred to in H.1. or H.2. above is observed and, if it has not been influenced by extraneous noise sources, is recorded.
- J. The vehicle's engine speed is returned to idle and the procedures set out in paragraphs H. and I. are repeated until two maximum sound levels within 2 dbA of each other are recorded. The two maximum sound level readings are then averaged; and
- K. The average obtained in accordance with paragraph J., with a value of 2 dbA subtracted therefrom to allow for variations in the test conditions and in the capabilities of meters, is the vehicle's interior sound level at the driver's seating position for the purposes of determining compliance with the requirements of this test procedure.

**Retroreflective Sheeting
Daytime Color Specificaion**

The daytime color of the RETROREFLECTIVE sheeting used to enhance school bus safety requires different color tolerances in order to assure optimum safety benefit, as well as to be consistent with the color of the school bus.

The color of the RETROREFLECTIVE sheeting shall conform to the table below when samples applied to aluminum test panels are measured as specified in ASTM E1164. For colorimetric measurements, material is illuminated by Standard Illuminant D65 at an angle of 45 degrees with the normal to the surface the observations are made in the direction of the normal (45/0 degree geometry). The inverse (0/45 degree geometry) with the illuminant at the normal to the surface and the observations at 45 degrees with the normal to the surface may also be used. For materials which are directionally sensitive (e.g., prismatic sheeting), the colorimetric measurements are made using circumferential illumination and viewing and the various measurements are averaged. Calculations shall be done in accordance with ASTM E308 using the CIE 1931 (2 degree) Standard Observer.

Retroreflective Sheeting Daytime Color Chromaticity Coordinates of Corner Points Determining the Permitted Color Area					
		1	2	3	4
Yellow	X	0.484	0.513	0.517	0.544
	Y	0.455	0.426	0.482	0.455
Luminance Factor (Y%)		Minimum		10.0	
		Maximum		36.0	

School Bus Seat Upholstery Fire Block Test

A. Test Chamber

Cross Section

The suggested test chamber is the same cross section as the bus body in which seats are used with the rear section on each end. If a bus section is not used, the cross section is to be 91 inches +/-1 inch in width x 75 inches +/-3 inches in height. There shall be a door, which does not provide ventilation, in the center of each end of the test chamber. The doors shall be 38 inches +/-3 inches in width and 53 inches +/-3 inches in height and include a latch to keep the doors closed during the test. (See Figure 1.)

Length

The length of the test chamber shall allow three rows of seats at the minimum spacing recommended by the installer. (See Figure 1, Detail A.)

In order that different types of seats may be tested in the same chamber. A length tolerance of plus 45 inches is allowed.

Ventilation

One ventilation opening shall be in each end of the test chamber and shall be 325 square inches +/-25 square inches. The bottom of the opening shall be 30 inches +/-3 inches above the chamber floor. Ventilation openings shall be on the same side of the test chamber. (See Figure 1.)

There shall be no ventilation openings along the length of the test chamber.

A forced air ventilation system may not be used.

Baffles shall be used to prevent wind from blowing directly into the ventilation openings.

Camera View Area

An opening covered with glass shall be provided at the midpoint of the test chamber length for camera viewing. The opening shall allow the camera to view the seat parallel to the seat width. (See Figure 1).

B. Test Sample

The sample shall be a fully-assembled seat.

Record the weight of all padding and upholstery prior to assembly. Record the weight of the fully-assembled seat.

C. Ignition Source

A paper grocery bag with dimensions of approximately seven inches x 11 inches x 18 inches is used to contain double sheets of newsprint (black print only, approximately 22 inches x 28 inches). The total combined weight of bag and newspaper shall be seven ounces +/- .5 ounces.

D. Test Procedure

1. Install three (3) seats in the test chamber at minimum spacing, per installer recommendation. Seats shall be perpendicular to the dimension indicated as "length" in Figure 1. Install so that seat frames will not fall during the test. Seat width shall be determined so that maximum passenger capacity per row (two (2) seats) for the seat style shall be tested.
2. For each test, position the ignition source in the following positions outlined. The widest seat in the center row shall be tested.

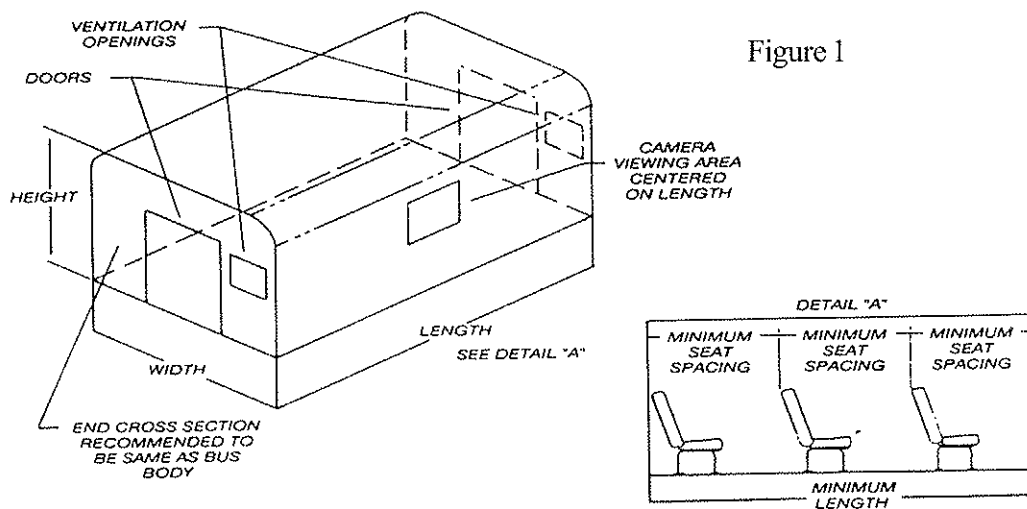

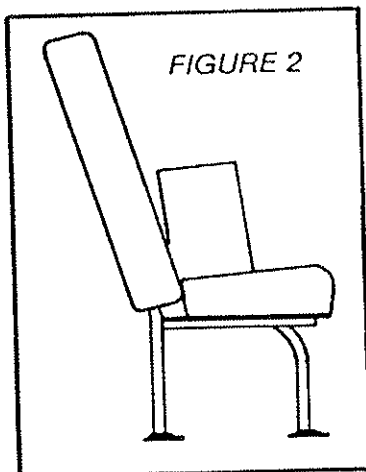

214

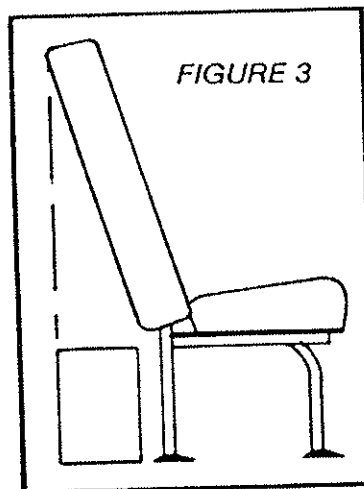

Position A.

Position ignition source with 18-inch dimension in contact with the seat cushion and touching the seat back. Center the bag on top of the cushion. (See Figure 2.)

Position B.

Position the ignition source on the floor behind the seat with 18-inch dimension on floor and parallel to seat width centered on width so that the rear of bag does not extend beyond the rear seat back. (See Figure 3.)

Position C.

Position the ignition source on the floor on the aisle side of the seat with 18-inch dimension on the floor and perpendicular to the seat width touching the seat leg with centerline of the bag at the center of the seat back. (See Figure 4.)

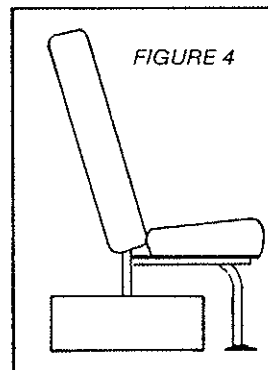

3. A wooden match shall be used to light the ignition source. Time the test beginning when the ignition source is on fire and ending when all flames are out.
4. After each ignition source position test, weigh seat assembly, including loose material which has fallen off the seat onto the floor.

E Performance Criteria

For each ignition source position test, the seat tested must meet all of the following criteria. A new seat specimen may be used for each ignition source position test.

1. Maximum time from ignition to flameout shall be 8 minutes.
2. Flame shall not spread to any other seat with the ignition source in Position A and Position C.
3. Weight loss may not exceed 10 percent of the pretest weight of padding upholstery.

APPENDIX C
Alternative Fuels
Bibliography

APPENDIX C

BIBLIOGRAPHY

A.G.A. Requirements for Natural Gas Vehicle (NGV) Conversion Kits, No. 1-85. American Gas Association Laboratories, August 20, 1995.

An Alternative Transportation Fuel, "The LNG Option." Roy E. Adkins Cryogenic Fuels, Inc., September, 1989.

An Analysis of the Economic and Environmental Effects of Natural Gas as An Alternative Fuel, EA 1989-10. December 15, 1989.

Basic Requirements for Compressed Natural Gas Vehicle (NGV) Fuel Containers, ANSI/AGA NGV2, 1992. American Gas Association Laboratories.

"CAA Clean Fuel Fleet Requirements." Presented by Glenn W. Passavant, U.S. EPA. 1992 SAE Government/Industry Meeting, Washington, D.C., April 30, 1992.

"Campaigning for NGV's": 4th Annual Meeting Proceedings. Dallas, Texas: The Natural Gas Vehicle Coalition, June 24-25, 1992.

Compressed Natural Gas Conference Proceedings, SAE P - 129 (compilation of papers). Pittsburgh, Pennsylvania: June 22-23, 1993.

Compressed Natural Gas (CNG) Demonstration Project: Transit Facility for Buses. M.S. Consultants, Inc. for the Ohio Department of Transportation, June, 1991.

Compressed Natural Gas (CNG) Vehicular Fuel Systems, ANSI/NFPA 52 - 1988 Edition. National Fire Protection Association.

Directory of Natural Gas Vehicle Refueling Stations, Products and Services, 1991 & 1992. Editions American Gas Association.

"Putting the Future of Methanol in Proper Perspective" By J.R. Crocco - April, 1992 Presented to 1992 SAE Government/Industry Meeting, Washington, DC.

"Extent of Indoor Flammable Plumes Resulting from CNG Bus Fuel System Leaks SAE 922486" - November, 1992 By Michael J. Murphy, Susan T. Brown, & David B. Phillips-Battelle.

Florida School Bus Alternate Fuel Manual. Florida Department of Education (Suite 824, 325 West Gaines Street, Tallahassee, FL 322399-0400), 1992.

49 CFR Part 571. Federal Motor Vehicle Safety Standards. NHTSA (400 Seventh Street SW, Washington, DC 20590).

Methanol Use in School Transportation: An Expedition Through the Mind Set of America, SAE 951966 by Wayne B. Johnston and George Karbowski. Presented to SAE Future Transportation Technology Conference and Exposition, Costa Mesa, CA.

Potential for Compressed Natural Gas Vehicles in Centrally-Fueled Automobile, Truck and Bus Fleet Applications, By Michael E. Samsa. Gas Research Institute, Strategic Planning and Analysis Division, June, 1991.

Directory of National Gas Vehicle Refueling Stations, Products And Services, 1991 and 1992 Editions. American Gas Association.

Technology Conference Proceedings Dallas, Texas - June 24-25, 1992 The Natural Gas Vehicle Coalition .

Glossary of Alternative Fuels

ARB: The abbreviation for the (California) Air Resources Board, the state agency in California which sets the states emission standards.

BTU: A unit of work or energy known as a British Thermal Unit. One BTU is the energy required to increase the temperature of one pound of water by one degree Fahrenheit.

Bi-fuel: Used to describe a bus capable of running on either of two fuels, although not simultaneously. Engines which can be switched to run on either CNG or gasoline are examples.

Carbon monoxide: A product of incomplete combustion; this gas is colorless, odorless and very poisonous. It does not contribute to smog.

Catalytic converter: An exhaust after-treatment device containing a catalytic material that is used to burn off or reduce unburned fuel or gases and thus reduce emissions, particularly NOx and hydrocarbons. Diesel converters run at cooler temperatures than do gasoline converters and require different catalysts.

Cetane number: A measure of self-ignition properties of a fuel after injection in a diesel engine. It relates to the knock properties of fuel. The higher the number, the more easily the fuel will ignite under compression; therefore, higher cetane fuels are usually preferred in diesels engines.

Combustible gas sensor: Detector capable of sensing the presence of natural gas.

Cryogenic: Relates to storage and use at very low temperatures. LNG requires cryogenic systems.

Dual-fuel engine: Also "flex fuel," used to describe a gasoline-methanol dual-fuel engine using mixtures of gasoline and methanol, such as M85, which is 15% gasoline and 85% methanol. Dual-fuel engine can also refer to engines operating on any other mixture of fuels simultaneously, such as engines which run on a mixture of CNG and diesel.

FMVSS: Federal Motor Vehicle Safety Standard.

Formaldehyde: A chemical compound that is a by-product of combustion from engines. Concentrations may be particularly high in emissions from engines fueled by methanol.

Fumigate: Literally means "to form a gas or disperse one gas in another." The term is used to describe the injecting of gas, usually CNG, into the intake air of the engine.

G/bhp-hr: The amount of a pollutant generated in one hour measured in grams per brake horsepower.

GVWR: Gross Vehicle Weight Rating means the value specified by the manufacturer as the loaded weight in pounds of a single vehicle, which shall not be less than the sum of the unloaded vehicle weight, plus the rated cargo load. For school buses, the rated cargo load is 120 pounds times the vehicle's designated seating capacity, plus 150 pounds for the driver.

Hydrocarbons: A gaseous compound formed by incomplete combustion and comprised of unburned and partially burned fuel. It combines with NOx and sunlight to form ozone and is a major contributor to smog.

Lean burn: Uses more air than is needed for theoretical complete combustion. This added air allows combustion to take place at a lower temperature, thus reducing the emissions NO_x and CO.

Nebula combustion chamber: A unique high-turbulence combustion chamber in the top of a piston, which is particularly effective in efficient burning of lean gas-air mixtures.

NFPA: National Fire Protection Association

NO_x: Abbreviation for nitrogen oxides, the gaseous compounds which combine with hydrocarbons and sun light to form ozone, an air pollutant that contributes to smog.

Octane number: A measure of anti-knock properties of a fuel that relates to spark ignition engines. The higher the number, the more resistant to knocking. Higher output and more efficient engine designs can be used with higher octanes.

Ozone: A pollutant formed from NO_x, hydrocarbons and sunlight. This gas has an irritating odor, is poisonous and is used as an oxidizing agent for bleaching.

Particulate traps: An exhaust treatment device used to collect (trap) and periodically burn off particulates and other potential problem emission gases formed in engine exhaust.

Particulates: Small solid particles (soot, etc.) formed by engine combustion. Visible particulates are seen in smoke; however, invisible particles may be present in smokeless exhaust.

Pilot Ignition engine: An engine using a small quantity of diesel fuel to provide an ignition source for an alternative fuel that will not ignite on its own in a compression cycle.

Port Injection: Similar to the throttle body system except that the fuel is injected near each cylinder intake port. The injectors and their controls can be individually controlled for maximum performance and emissions control.

Reformulated gasoline: Also known as “oxygenated gasoline,” reformulated gasoline has oxygen added to improve combustion and reduce emissions.

Repower installation: A dedicated natural gas or other engine which was not part of the original chassis at the time of manufacturing.

Stoichiometric burn: Use of fuel and air (or oxygen) in the exact ratio needed for complete combustion to generate maximum efficiency and power.

Throttle body injection: A gasoline fuel injection system in which the fuel is injected directly into the air intake pipe or manifold. No carburetor is required; electronics monitor engine variables and control the rate of fuel injected.

UL: Underwriters Laboratory.

ALTERNATIVE FUELS COMPARISON CHART

	Clean Diesel	Reformulated Gasoline	Methanol	Ethanol	Compressed Natural Gas (CNG)	Liquid Natural Gas (LNG)	Propane	Electric Power
Environmental Issues								
Pro	<p>Reduced emissions</p> <p>Reduces particulate material 20%-50% in older engines</p> <p>Few safety problems</p>	<p>Should meet emission regulations through year 2000</p> <p>Reduced emissions in older engines</p>	<p>Low NOx particulates</p> <p>Disposes in water and bio-degradable</p> <p>Diverse fuel sources</p>	<p>Low NOx and particulates</p> <p>Disposes in water and bio-degradable</p> <p>Renewable resource</p>	<p>Low emissions</p> <p>Smokeless</p> <p>Available from the well, minimum processing</p>	<p>Low emissions</p> <p>Smokeless</p> <p>Available from the well, minimum processing</p>	<p>Low emissions</p> <p>Smokeless</p>	<p>Zero emissions</p> <p>Electricity often produced from renewable domestic energy sources</p> <p>Extremely quiet</p>
Con	<p>Needs particulates and NOx reduction</p> <p>Still some smoke (cold and high altitude)</p> <p>Spill/leakage contamination</p>	<p>Still high in smog-forming emissions</p> <p>Spill/leakage contamination</p> <p>Non-renewable resource</p>	<p>Generates formaldehyde</p> <p>Very toxic</p>	<p>Slight smoking</p> <p>Generates formaldehyde, but less than methanol</p> <p>Uses about the same energy to produce as it generates</p>	<p>Needs NOx reduction</p> <p>Requires energy to compress</p>	<p>Needs NOx reduction</p> <p>Requires energy to liquefy and cool</p>	<p>Needs NOx reduction</p> <p>Requires energy to liquefy</p>	<p>Electric power from coal or oil does not eliminate overall emissions</p> <p>Battery disposal is a concern</p>
Operational Issues								
Pro	<p>Readily available and uses current distribution</p> <p>Minimal cost increase</p> <p>Very efficient, good mileage</p> <p>Usable in older engines</p> <p>Ample basic worldwide supply</p>	<p>Will be readily available when required</p> <p>Minimal cost increase</p> <p>Usable in older engines</p> <p>Ample basic worldwide supply</p>	<p>High octane for efficient spark ignition combustion</p> <p>Liquid form easy to distribute</p> <p>Blends well with gasoline</p>	<p>High octane for efficient spark ignition combustion</p> <p>Liquid form easy to distribute</p> <p>Blends well with gasoline</p>	<p>Gasoline conventions available</p> <p>Attractive fuel cost</p> <p>Ample domestic supply</p> <p>Low engine maintenance</p> <p>Minimum explosion hazard</p> <p>Vapors lighter than air, disperse quickly</p>	<p>Basic engine same as CNG</p> <p>Attractive fuel cost potential</p> <p>Ample domestic supply</p> <p>Less than 1/2 tank space of CNG</p> <p>Low engine maintenance</p> <p>Minimal explosion hazard</p> <p>Vapors lighter than air, disperse quickly</p>	<p>Fairly wide distribution</p> <p>Long-term experience in vehicle</p> <p>Good cold starting</p>	<p>Distribution system already in place (power generation and transmission system)</p> <p>Can be produced as hybrid vehicles</p> <p>Extremely quiet</p> <p>Low cost per mile to operate</p>
Con	<p>Hard cold starting</p> <p>Foreign oil dependency</p>	<p>May require new catalytic converters</p> <p>Over twice the cost per mile vs. diesel</p> <p>Foreign oil dependency</p>	<p>Corrosive</p> <p>Invisible fumes</p> <p>Explosive vapors</p> <p>Hard cold starting with spark ignition</p> <p>Limited production capability</p> <p>Limited fuel locations</p> <p>45% energy of diesel (low range or large fuel tanks)</p>	<p>High cost to produce</p> <p>Limited production capability</p> <p>Limited fuel locations</p> <p>50% of energy of diesel (low range or large fuel tanks)</p>	<p>Slow refueling</p> <p>Limited vehicle fuel distribution</p> <p>Fuel quality variation</p> <p>High-pressure on-board fuel storage, heavy and complex</p> <p>Limited energy and range, relative to diesel</p>	<p>Slow refueling</p> <p>Limited availability today</p> <p>Cryogenic handling (-260°F)</p> <p>Must vent fuel system after 7 to 10 hours</p> <p>High-pressure on-board fuel storage, heavy and complex</p> <p>Limited energy and range, relative to diesel</p>	<p>Slow refueling</p> <p>Limited energy and range, relative to diesel</p> <p>Vapors heavier than air, explosion potential</p>	<p>Low range due to weight and storage capacity of batteries</p> <p>Current cost for vehicles extremely high</p> <p>Overall vehicle weight limits passenger capacity</p> <p>Current technology requires battery replacement during life of vehicle</p>

APPENDIX D
Test for Frontal
Impact
Crashworthiness

Appendix D (Normative)

Test for Frontal Impact Crashworthiness

D.1 Purpose

This appendix specifies equipment, conditions and procedures for conducting a sled impact test to simulate the dynamic loading that Wheelchair Tiedown and Occupant Restraint System (WTORS) components used with forward-facing wheelchairs and occupants can be expected to experience in a 48-km/hr frontal crash. For WTORS designed for use with a range of wheelchair types and sizes, the test procedures specify use of a rigid, reusable surrogate wheelchair (SWC) that complies with the specifications documented and illustrated in Appendix D. For a WTORS designed only for use with a specific wheelchair having unique design features or components required by the WTORS, the test procedures provide for conducting the test with the appropriate production or prototype wheelchair. The surrogate, production, or prototype wheelchair is referred to as the test wheelchair.

D.2 Equipment To Be Tested

A complete, unused WTORS, including all fittings, anchorages, fasteners, and instructions for installation and use, shall be provided for testing. If a WTORS is designed to make use of the OEM vehicle restraint system, the WTORS manufacturer shall provide a representative vehicle restraint system for testing. If modifications to the WTORS are necessary to interface with the test wheelchair, or if changes from recommended installation geometry and/or hardware are required to interface with the sled platform, such modifications shall be made or approved by the WTORS manufacturer and shall not affect the basic structural design and dynamic strength of the WTORS.

For WTORS designed to be used with a specific wheelchair, or for WTORS designed to rely on the wheelchair structure to transfer occupant restraint loads to the vehicle, a production or prototype wheelchair of the type and model required shall be provided for each test, weighted with actual or simulated components such as batteries, motors, and electronic components, as is appropriate to the style of wheelchair.

D.3 Test Equipment

The frontal impact test should be performed with impact simulator equipment that includes:

- D.3.1 An impact sled with a flat, structurally rigid platform, suitably reinforced to accept WTORS anchorages, and capable of producing the impact conditions specified in A.4.
- D.3.2 A rigid structure for anchorage of upper restraint hardware.
- D.3.3 A track or guide path to permit only unidirectional movement of the sled during the impact event.
- D.3.4 An anthropomorphic test dummy (ATD) with a total mass of 73.5 + 1 kg. (The ATD shall simulate the response of a human occupant and shall be of a type that has proven to produce repeatable results when used in crash testing. Suitable ATDs at the time of publication are Hybrid II, Hybrid III, OPAT, and TNO-10).
- D.3.5 A test wheelchair consisting of either a surrogate wheelchair that complies with the specifications of Appendix D, or a production or prototype wheelchair as required for a specific WTORS design.

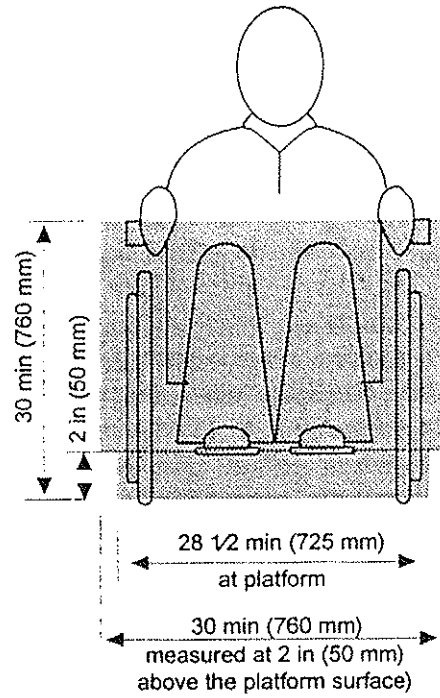
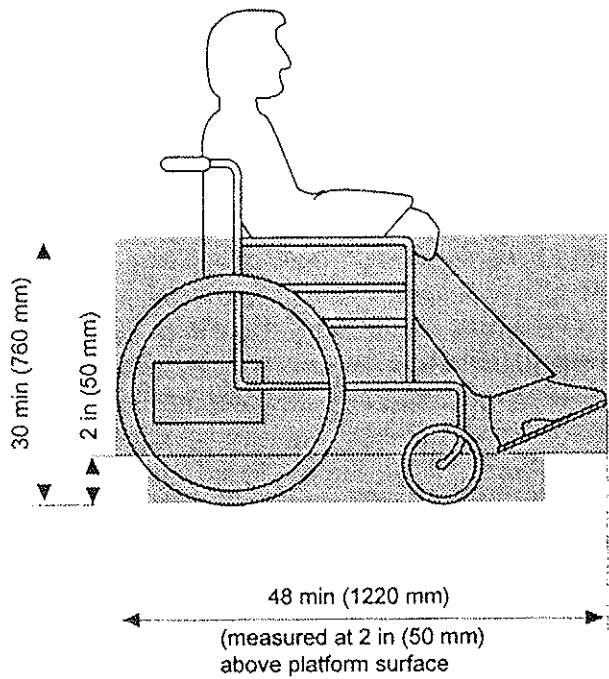

Wheelchair or Mobility Aid Envelope

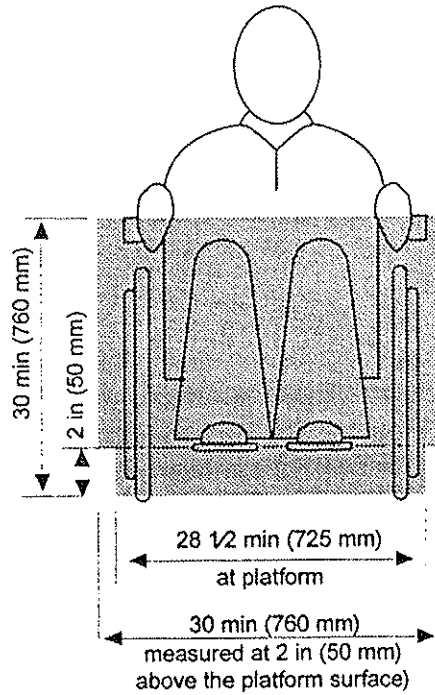
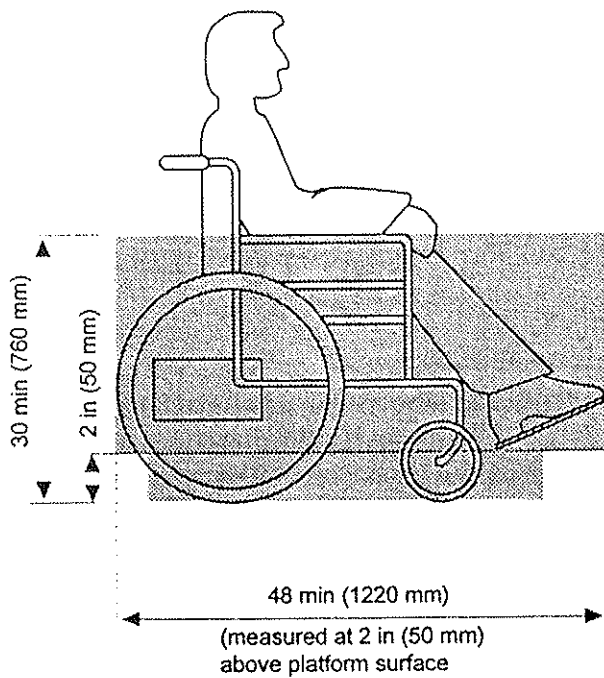

Wheelchair or Mobility Aid Envelope

- D.3.6 High-speed camera or video equipment for recording the kinematics of the test wheelchair and the ATD at a minimum of 500 frames per second.
- D.3.7 Equipment to measure the ATD and test wheelchair horizontal excursions specified in A.7.2 to an accuracy of + 5 mm.
- D.3.8 A means to process the sled accelerometer signals as specified in A.4.2 in order to measure and record the acceleration-time history of the sled platform in the direction of sled travel during the impact event to an accuracy of + 0.5 g.
- D.3.9 A means to measure the horizontal velocity change (ΔV) during the impact deceleration/acceleration event. Mathematical integration of the deceleration-time pulse is recommended to determine the sled ΔV :

$$\Delta V = \int_{t_0}^{t_f} a(t) dt$$

where: $a(t)$ is the sled deceleration time history (i.e., sled pulse) in the impact direction,

t_0 is time-zero, the time when the sled starts to decelerate, as indicated by a sudden and final departure of $a(t)$ from zero g,

t_f is the time at which the sled deceleration pulse returns to zero (see Figure A.1).

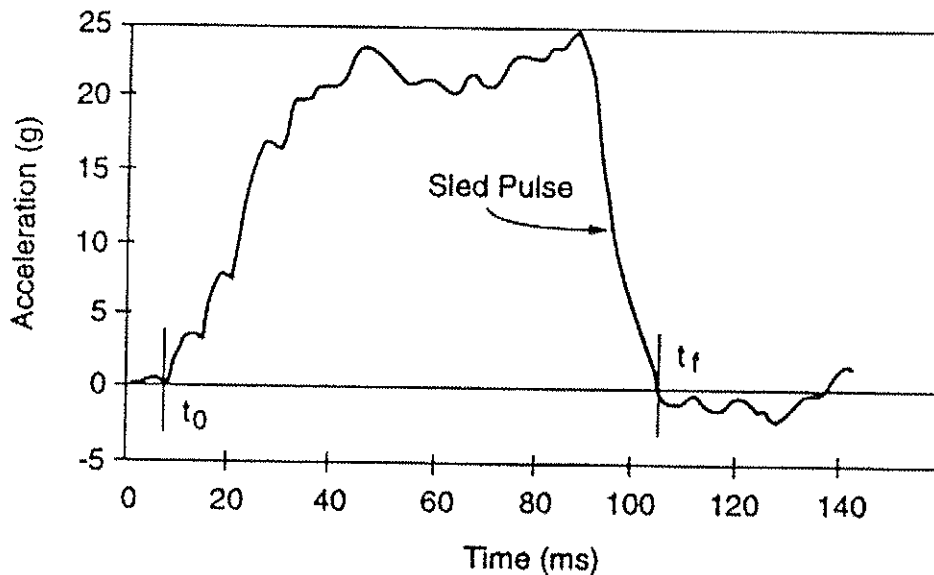
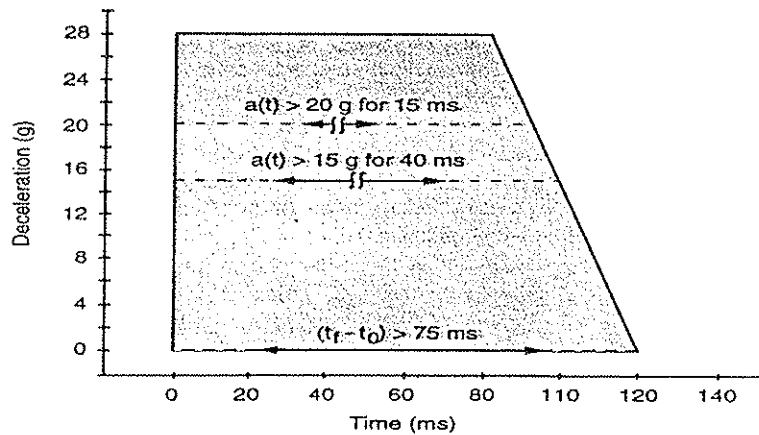

Figure A.1 - Integration limits for determining ΔV .

D.4 Sled Performance

- D.4.1 The sled platform with WTORS, test wheelchair, and ATD installed as described in D.6 shall be subjected to a horizontal velocity change of 48 km/h (+2/-0) in the direction of impact using a sled acceleration/deceleration pulse that complies with testing standards.
- D.4.2 The sled accelerometer signal shall be processed according to SAE J211 as follows:
- D.4.2.1 Prefilter to Channel Class 1000 (-4 dB at 1650 Hz),
 - D.4.2.2 Digitize at 10,000 Hz, and D.4.2.3 filter digitized signal to Channel Class 60 (-4 dB at 100 Hz).
- D.4.3 The processed sled deceleration-time pulse shall:
- D.4.3.1 Fall within the shaded corridor of Figure A.2,
 - D.4.3.2 Exceed 20 g's for a cumulative time period of at least 15 ms, D.4.3.3 exceed 15 g's for a cumulative time period of at least 40 ms, and D.4.3.4 have a duration of at least 75 ms from t_0 to t_r .

Figure A.2 - Deceleration pulse corridor for a 48 (+2/-0) km/hr delta V



D.5 Preparation and Calibration of Test Equipment

Prior to conducting the test, the following shall be done:

- D.5.1 Check to make sure that the sled accelerometer has been calibrated by the manufacturer or a designated representative within six months of the test date.
- D.5.2 Calibrate the signal processing system for the sled accelerometer.
- D.5.3 Inspect the ATD to insure that all primary components are intact and functioning.
- D.5.4 Adjust the ATD to achieve a static resistance of 1 g at each joint indicated by just-noticeable movement from the weight of the distal body segment.

- D.5.5 Place snug-fitting cotton clothing on the pelvis, thighs, and torso of the ATD.
- D.5.6 If the surrogate wheelchair is used:
 - D.5.6.1 Adjust the location of the simulated battery mass to accommodate WTORS components that are fastened to the wheelchair and/or to provide adequate clearance to vehicle-anchored WTORS components,
 - D.5.6.2 Inflate the rear tires to $414 + 69$ kPa and inflate the front tires to $759 + 69$ kPa,
 - D.5.6.3 Inspect the sidewalls of the tires for abrasion and/or cracking and replace tires if worn,
 - D.5.6.4 Inspect the seat plate and plate-support structures and replace if deformed,
 - D.5.6.5 Inspect all frame joints and components and repair if there are signs of fatigue or deformation.
- D.5.7 If the test involves use of a production or prototype wheelchair:
 - D.5.7.1 Inspect and adjust the wheelchair condition according to the manufacturer's instructions.
 - D.5.7.2 Replace battery acid with water.
 - D.5.7.3 Replace electronic components and motors with equivalent masses, if desired.

D.6 Setting Up and Conducting the Test

Perform the following in sequence:

- D.6.1 Set up the high-speed camera or high-speed video system to record a lateral view of the test sled, test wheelchair, and ATD during the impact event.
- D.6.2 Fasten any wheelchair add-on components to the test wheelchair.
- D.6.3 Position the test wheelchair facing forward on the sled with wheelchair reference plane parallel to the direction of sled travel.
- D.6.4 Install the wheelchair tiedown anchorages in accordance with the manufacturer's instructions¹ on the sled platform, selecting anchorage points for strap-type systems that:
 - a. Are symmetrical about the longitudinal axis of the test wheelchair;
 - b. Achieve angles of the rear tiedown straps of $45 + 3$ degrees and angles of the front tiedown straps of $60 + 3$ degrees with respect to the horizontal, measured (or projected) in a plane parallel to the wheelchair reference plane; and
 - c. Achieve angles of the rear tiedown straps of $0 + 3$ degrees and angles of the front tiedown straps of $15 + 3$ degrees (angled outward) relative to the horizontal, measured (or projected) in a vertical plane perpendicular to the wheelchair reference plane.
- D.6.5 Secure the test wheelchair in accordance with the WTORS manufacturer's instructions.
- D.6.6 Install load cells on tiedown straps if applicable and desired.
- D.6.7 Tension any tiedown straps to the manufacturer's specifications, making sure that the test wheelchair reference plane remains aligned with the direction of sled travel.

¹ If fasteners provided with the WTORS are incompatible with the sled platform, replacement fasteners shall be of the same thread size and specification. The anchor bolt may also be fastened directly into a tapped hole in the sled platform.

- D.6.8 Position the ATD in the test wheelchair sitting upright and symmetrically positioned about the wheelchair midline, with the pelvis and elbows as close to the seatback of the test wheelchair as possible.
- D.6.9 Install the occupant restraint system in accordance with the manufacturer's instructions,
 - a. Selecting anchor points for the pelvic belt to achieve angles within the range specified in Figure 7 of this document; and
 - b. Selecting anchor points for the upper torso belt within the preferred zone or zones shown in Figures 8, 9, or 10, as applicable.
- D.6.10 Install belt-webbing load cells on occupant restraint belts if desired.
- D.6.11 If an emergency-locking or automatic-locking retractor is provided, adjust the pelvic restraint for minimum slack. If no emergency-locking or automatic-locking retractor is provided, adjust the tension of the pelvic restraint to a snug fit over the ATD's pelvis.
- D.6.12 If an emergency-locking or automatic-locking retractor is provided, adjust the shoulder belt for minimum slack or minimum preloading. If no emergency-locking or automatic-locking retractor is provided, adjust the shoulder belt to a snug fit with a 75 x 75 x 75 mm block placed between the belt and the ATD's sternum.
- D.6.13 Mark the webbing at WTORS adjustment mechanisms to determine slippage during the test.
- D.6.14 Position high-contrast targets on the sides of the ATD and test wheelchair in view of the high-speed recording equipment at:
 - a. The lateral aspect and center of the ATD's knee joint;
 - b. The point P of the surrogate wheelchair (see Figure 1 and Figures D.1 through D.3 in Appendix D); or
 - c. A point on the side of the seatback of a production or prototype wheelchair that is as close to the wheelchair point P as possible.
- D.6.15 Verify that the test wheelchair reference plane is aligned within + 3 degrees of the direction of sled travel.
- D.6.16 Record the locations of all WTORS anchor points relative to the test wheelchair and the angles of all tiedown straps and pelvic restraint belts relative to the horizontal longitudinal axis of the sled platform.
- D.6.17 Conduct the impact test.

D.7 Measurement and Calculation of Test Results

After the test:

- D.7.1 Examine the test wheelchair, ATD, and WTORS components to determine and/or measure:
 - D.7.1.1 Whether the ATD remained in the test wheelchair;
 - D.7.1.2 Whether the test wheelchair remained on the test platform;
 - D.7.1.3 Any change in orientation of the test wheelchair reference plane relative to the direction of sled travel;
 - D.7.1.4 Any slippage at each WTORS adjustment mechanism;
 - D.7.1.5 Whether any load-carrying parts became separated, deformed, or fractured;
 - D.7.1.6 If the ATD and test wheelchair could be released from the WTORS without the use of tools.

- D.7.2 Analyze the high-speed films or video recordings to determine the following with an accuracy of + 5 mm:
- D.7.2.1 $Exhead_{peak}$ = the horizontal distance relative to the sled platform between the most forward point on the ATD's head above the nose at time t_0 , to the most forward point on the ATD's head at the time of peak head excursion;
- D.7.2.2 $Exknee_{peak}$ = the horizontal distance relative to the sled platform between the ATD knee-joint target at time t_0 , to the knee-joint target at the time of peak knee excursion; and
- D.7.2.3 $ExWC_{peak}$ = the horizontal distance relative to the sled platform between the contrast target placed at or near point P on the test wheelchair at time t_0 , to the point P target at the time of peak wheelchair excursion.
- D.7.3 Calculate the ratio $(Exknee_{peak})/(ExWC_{peak})$.

D.8 Test Report

The test report should include:

- D.8.1 A description of the test facility including the type of impact simulated, instrumentation and signal processing techniques, the frame speed for each film and/or video produced, methods for measuring sled velocity change and deceleration, methods used to measure ATD and test wheelchair excursions, and the accuracy of excursion measurements;
- D.8.2 A full identification of the WTORS, anchorage fasteners, test wheelchair, and ATD used;
- D.8.3 Pre-test measurements documenting the locations of all WTORS anchorages relative to the test wheelchair and angles of all tiedown straps and pelvic restraint belts relative to the horizontal and measured in vertical planes perpendicular to, or parallel to, the wheelchair reference plane, as appropriate;
- D.8.4 The angles of all tiedown straps and pelvic restraint belts relative to the horizontal obtained by projecting the actual angles onto a vertical plane perpendicular to the wheelchair reference plane (side view) and a vertical plane perpendicular to the wheelchair reference plane (front or rear view);
- D.8.5 A description of the test setup including a statement about any parts or fasteners used in the test that were not provided by the WTORS manufacturer;
- D.8.6 Whether the ATD remained in the test wheelchair;
- D.8.7 Whether the test wheelchair remained on the test platform;
- D.8.8 The change in the orientation of the test wheelchair reference plane, if measurable, in comparison with the initial test orientation;
- D.8.9 Identification of any WTORS load-carrying parts that became separated, deformed, or fractured during the test;
- D.8.10 The webbing slippage in millimeters at each WTORS adjustment mechanism;

- D.8.11 The peak horizontal excursions specified in D.7.2, and whether any of the excursions exceeded the limits in Table 2 of this recommended practice;
- D.8.12 A statement as to whether the ATD and test wheelchair could be released from the WTORS without the use of tools;
- D.8.13 A statement as to whether the ATD was loaded by the test wheelchair based on the results of the calculation in 6.2.4;
- D.8.14 A statement as to whether the WTORS complied with all of the performance requirements specified in 6.2 of this recommended practice;
- D.8.15 A graph of the sled deceleration time history for the test in relation to the deceleration corridor of Figure A.2; and
- D.8.16 The measured or calculated value of the test ΔV .

D.9 Performance Requirements

D.9.1 WTORS Components

D.9.1.1 All webbing, metal parts, buckles, release mechanisms, and adjustment mechanisms of wheelchair tiedown and occupant restraint systems shall comply with applicable subsections of No. FMVSS 209 as indicated in Table 1.

D.9.1.2 All materials used in WTORS shall comply with the flammability requirements of FMVSS No. 302.

Table 1
Applicable Subsections of FMVSS No. 209

Section	Component	Subject	Tests Referenced	Application*
S4.1 (a)	general design	occupancy	-	R
S4.1 (b)	pelvic restraint	design	-	R
S4.1 (c)	upper torso restraint	design	-	R
S4.1 (d)	hardware	burrs & sharp edges	-	R + TD
S4.1 (e)	release mechanism	design	-	R
S4.1 (g)	restraint assemblies	adjustment range	-	R
S4.1 (h)	webbing	unraveling	-	R + TD
S4.2 (a)	webbing	belt width	S5.1 (a)	R
S4.2 (b)	webbing	breaking strength	S5.1 (b)	R
S4.2 (c)	webbing	elongation	S5.1 (c)	R
S4.2 (d)	webbing	abrasion resistance	S5.1 (d), S5.3 (c)	R
S4.2 (e)	webbing	light resistance	S5.1 (e)	R + TD
S4.2 (f)	webbing	micro. resistance	S5.1 (f)	R + TD
S4.2 (g)	webbing	colorfastness	S5.1 (g)	R + TD
S4.2 (h)	webbing	stain resistance	S5.1 (h)	R + TD
S4.3 (a)	hardware	corrosion resistance	S5.2 (a)	R + TD
S4.3 (b)	hardware	temp. resistance	S5.2 (b)	R + TD
S4.3 (c)	floor fasteners	breaking loads	S5.2 (c)	R + TD
S4.3 (d)	buckle release	release force	S5.2 (d)	R
S4.3 (e)	adjustment device	adjustment force	S5.2 (e)	R + TD
S4.3 (f)	tilt-lock devices	locking angles	S5.2 (f)	R
S4.3 (g)	buckle latch	separation force	S5.2 (g)	R
S4.3 (h)	belt retractor	performance	S5.2 (h)	R
S4.3 (i)	belt retractor	performance	S5.2 (i)	R
S4.3 (j)	belt retractor	performance	S5.2 (j)	R
S4.3 (k)	belt retractor	performance	S5.2 (k), S4.4	R
S4.4 (a)	pelvic restraints	performance	S5.3 (a)	R
S4.4 (b)	3-pt restraints	performance	S5.3 (b)	R

* R = occupant restraint; TD = wheelchair tiedown

D.10 Frontal Sled Impact Test

When tested as specified in Appendix A, the WTORS shall:

- D.10.1 Retain the test dummy in the test wheelchair and on the test sled with the test wheelchair in an upright position;
- D.10.2 Not show any fragmentation or complete separation of any load carrying part; and
- D.10.3 Not allow the horizontal excursions of the test dummy and the test wheelchair to exceed the values given in Table 2.

Table 2
Horizontal Excursion Limits (mm)

Measurement Point	Excursion Variable	Pelvic & Shoulder Restraint
Test Wheelchair	$ExWC_{peak}$	200
Dummy Knee	$Exknee_{peak}$	375
Dummy Head	$Exhead_{peak}$	650

where,

$Exhead_{peak}$ = the horizontal distance relative to the sled platform between the most forward point on the dummy's head above the nose at time t_0 , to the most forward point on the dummy's head at the time of peak head excursion,

$Exknee_{peak}$ = the horizontal distance relative to the sled platform between the dummy knee-joint target at time t_0 , to the knee joint target at the time of peak knee excursion, and

$ExWC_{peak}$ = the horizontal distance relative to the sled platform between the contrast target placed at or near point P on the test wheelchair at time t_0 , to the point P target at the time of peak wheelchair excursion.

- D.10.4 Prevent the wheelchair from imposing forward loads on the occupant as indicated by:

$$(Exknee_{peak})/(ExWC_{peak}) > 1.1$$

- D.10.5 Allow removal of the anthropomorphic test dummy and the test wheelchair subsequent to the test without the use of tools.

D.11 Partial Engagement of Anchorage and Securement Components

When WTORS anchorage and securement components are tested as specified in Appendix B, all improper and partial engagements shall separate with a force of less than 22 N.

D.12 Webbing Slippage at Tiedown Adjustment Devices

When tested as specified in Appendix C, webbing adjustment mechanisms of the wheelchair tiedown system shall not show slippage greater than 25 mm.

Appendix D (Normative)

Specifications for Surrogate Wheelchair

D.1 Purpose

This appendix provides design, dimensional, material, and performance specifications for the surrogate wheelchair (SWC) referenced in the design requirements and tests of this recommended practice. These specifications are intended to provide a repeatable and reusable device that represents a typical adult-sized power wheelchair. Details for the design, fabrication, and maintenance of a suitable surrogate wheelchair are available in SAE J2252 - Surrogate Wheelchair Drawing Package and Maintenance Manual.

D.2 Specifications

The surrogate wheelchair shall be designed and fabricated with the features, dimensions, and specifications shown in Figures D.1 through D.3, and shall:

- D.2.1 Be of rigid construction;
- D.2.2 Have a total mass of 85 ± 1 kg;
- D.2.3 Have a lower frame design that is compatible with WTORS components of docking-type and clamp-type wheelchair tiedowns with little or no modification to those components;
- D.2.4 Allow for adjustment in the SWC-to-floor clearance distance to accommodate wheelchair an chorage components of docking-type tiedown systems;
- D.2.5 Have a center of gravity located 200 ± 25 mm forward of the rear axle and 325 ± 25 mm above the ground plane for the range of frame-to-floor clearance adjustments allowed;
- D.2.6 Provide two front securement points and two rear securement points for strap-type tiedowns at the locations indicated in Figure D.1 and with the geometry specified in Figure F.1 of Appendix F;
- D.2.7 Provide accessible and structurally sound locations 250 ± 10 mm above the ground plane for the addition of two rear securement points that simulate the horizontal axles a standard welded-Frame wheelchair and that are perpendicular to the surrogate wheelchair sideframe;
- D.2.8 Provide pelvic restraint anchor points on both sides that are located so that the angle of a pelvic restraint bolted to these points and placed over the pelvis of a 50th-percentile-male ATD seated in the surrogate wheelchair forms an angle between 45 and 60 degrees to the horizontal;
- D.2.9 Have a rigid, flat seat surface with dimensions shown in Figures D.2 that is oriented at an angle of 4 ± 1.5 degrees to the horizontal (front end up) when the SWC tires are resting on a flat horizontal surface;
- D.2.10 Have a rigid seatback with height and width dimensions indicated in Figure D.3 that is oriented at 8 ± 1.5 degrees to the vertical when the inflated tires of the SWC are resting on a flat horizontal surface;
- D.2.11 Have a 20-mm minimum thickness, perforated rubber pad with height and width dimensions indicated in Figures D.1 and D.3 fixed to the front surface of the rigid seatback;
- D.2.12 Be of durable construction such that there is no permanent deformation of the frame, seat surface, or seatback in a 48-km/h, 20-g frontal impact test with a 50th-percentile, 73.5 kg ATD positioned and restrained in the SWC;
- D.2.13 Have a detachable but rigid mounting plate for placement of a side-view contrast target at the location of reference point P outboard of tiedown and restraint system components on either side of the SWC;
- D.2.14 Have pneumatic front tires that, when inflated to 759 kPa, have a diameter of 230 ± 10 mm, a width of 75 ± 5 mm, and a sidewall height of 54 ± 5 mm;
- D.2.15 Have pneumatic rear tires that, when inflated to 414 kPa, have a diameter of 325 ± 10 mm, a

- width of $100 + 10$ mm, and a sidewall height of $70 + 5$ mm; and
- D.2.16 Include hard rubber stops located inboard of each rear wheel to limit rear tire compression during the frontal impact test of Appendix A to $45 + 5$ mm.

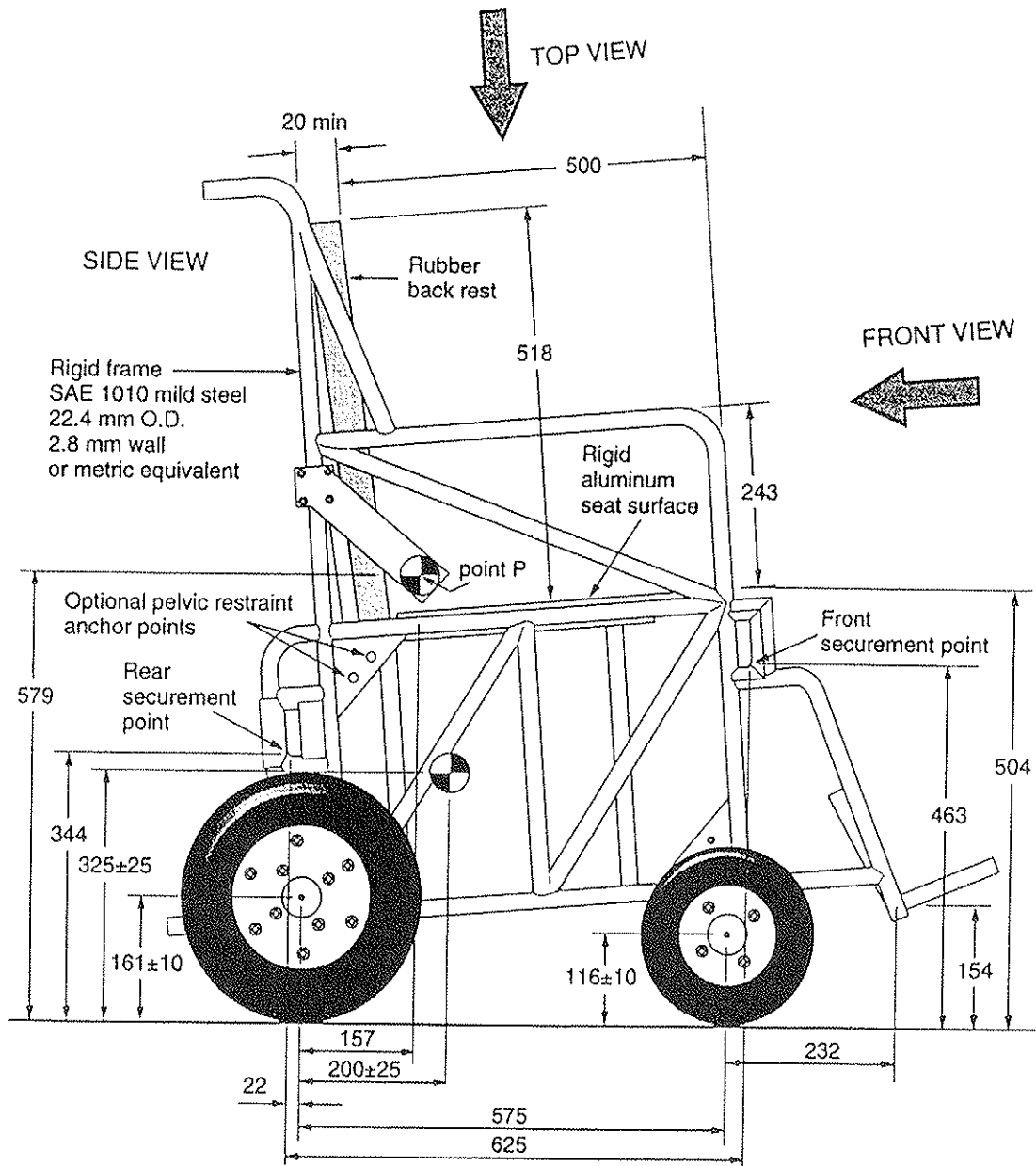

all dimensions are in mm with tolerances of ± 2 mm unless specified

Figure D.1 - Side-view drawing of surrogate wheelchair.

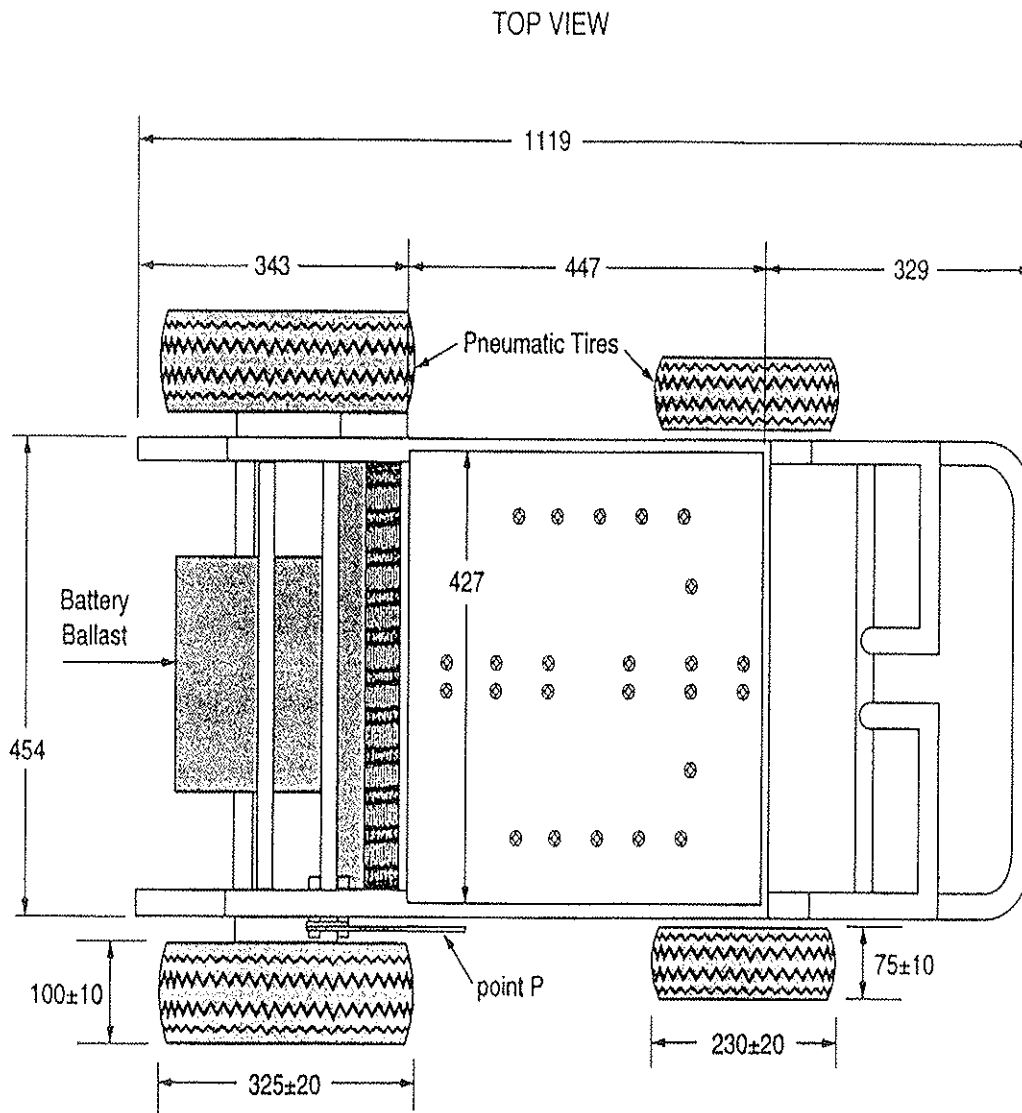

all dimensions are in mm with tolerances of ± 2 mm unless specified

Figure D.2 - Top-view drawing of surrogate wheelchair.

FRONT VIEW

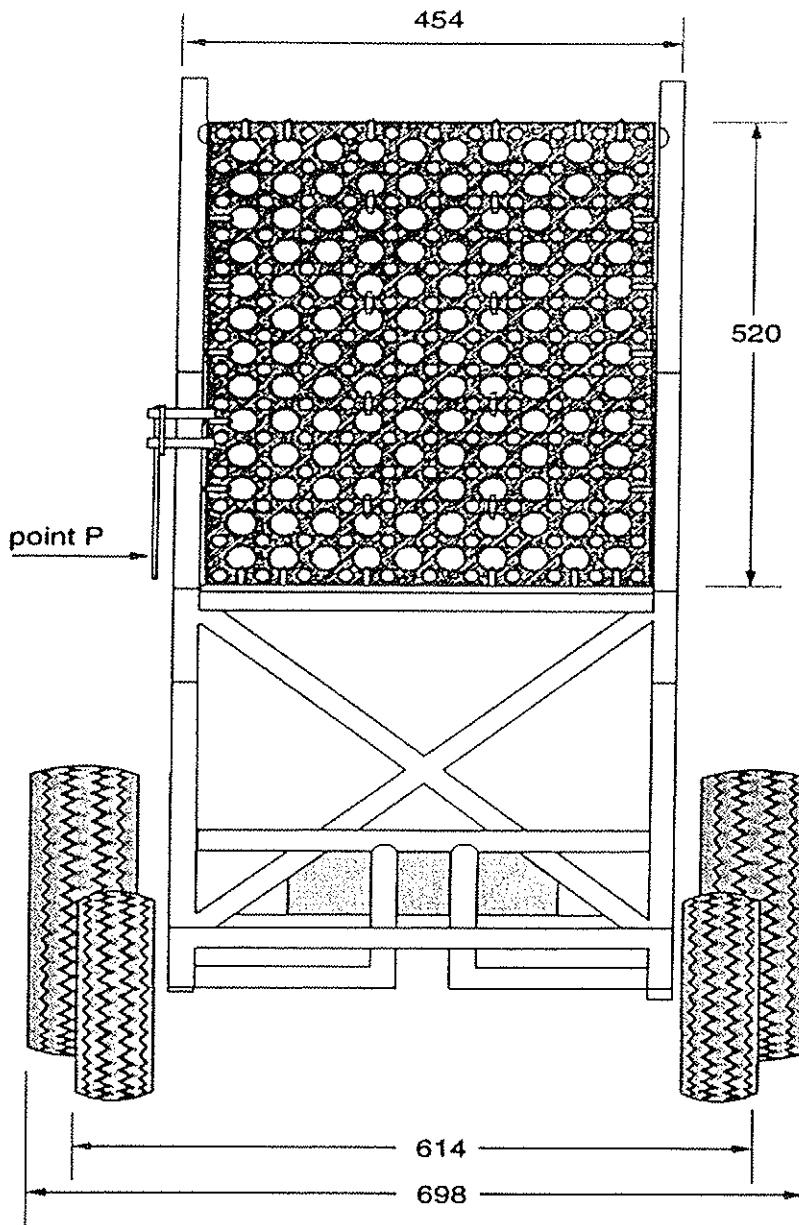

all dimensions are in mm with tolerances of ± 2 mm unless specified

Figure D.3 - Front-view drawing of surrogate wheelchair.

Vehicle Ramp 36 CFR 1192.23

- (1) **Vehicle ramp:** -(1) Design Load. Ramps 30 inches or longer should support a load of 600 pounds, placed at the centroid of the ramp distributed over an area of 26 inches by 26 inches, with a safety factor of at least 3 based on the ultimate strength of the material. Ramps shorter than 230 inches shall support a load of 300 pounds.
- (2) **Ramp surface:** The ramp surface shall be continuous and slip resistant, shall not have protrusions from the surface greater than 1/4 inch high, shall have a clear width of 30 inches, and shall accommodate both four-wheel and three-wheel mobility aids.
- (3) **Ramp threshold:** The transition from roadway or sidewalk and the transition from vehicle floor to the ramp may be vertical without edge treatment up to 1/4. Changes in level between 1/4 inch and 1/2 inch shall be beveled with a slope no greater than 1:2.
- (4) **Ramp barrier:** Each side of the ramp shall have barriers at least 2 inches high to prevent mobility aid wheels from slipping off.
- (5) **Slope:** Ramps shall have the least slope practicable and shall not exceed 1:4 when deployed to ground level. If the height of the vehicle floor from which the ramp is deployed is 3 inches or less above a 6-inch curb, a maximum slope of 1:4 is permitted; if the height of the vehicle floor from which the ramp is deployed is 6 inches or less, but greater than 3 inches, above a 6-inch curb, a maximum slope of 1:6 is permitted; if the height of the vehicle floor from which the ramp is deployed is 9 inches or less, but greater than 6 inches, a maximum slope of 1:8 is permitted; if the height of the vehicle floor from which the ramp is deployed is greater than 9 inches above a 6-inch curb, a slope of 1:12 shall be achieved. Folding or telescoping ramps are permitted provided they meet all structural requirements of this section.
- (6) **Attachment:** When in use for boarding or alighting, the vehicle so that it is not subject to displacement when loading or unloading a heavy power mobility aid and that no gap between vehicle and ramp exceeds 5/8 inch.
- (7) **Stowage:** A compartment, securement system, or other appropriate method shall be provided to ensure that stowed ramps, including portable ramps stowed in the passenger area, do not impinge on a passenger's wheelchair or mobility aid or pose any hazard to passengers in the event of a sudden stop or maneuver.
- (8) **Handrails:** If provided, handrails shall allow persons with disabilities to grasp them from outside the vehicle while starting to board, and to continue to use them throughout the boarding process, and shall have the top between 30 inches and 38 inches above the ramp surface. The handrails shall be capable of withstanding a force of 100 pounds concentrated at any point on the handrail without permanent deformation of the rail or its supporting structure. The handrail shall have a cross-sectional diameter between 1-1/4 inches and 1-1/2 inches or shall provide an equivalent grasping surface, and have eased edges with corner radii of not less than 1/8 inch. Handrails shall not interfere with wheelchair or mobility aid maneuverability when entering or leaving the vehicle.

Appendix, Vehicle

American Society for Testing and Materials
1916 Race Street
Philadelphia, PA 19103

Federal Specification TT-C-520b
General Services Administration
Specifications and Consumer Information
Distribution Center
Washington Navy Yard
Building 197
Washington, D.C. 20407

Product Standard PSI-66
U.S. Department of Commerce
14th and E Streets
Washington, D.C. 20230

School Bus Manufacturers Technical Council
National Association of State Directors of Pupil Transportation Services
116 Howe Drive
Dover, DE 19901
1-800-585-0341

Society of Automotive Engineers, Inc.
400 Commonwealth Drive
Warrendale, PA 15096
(412)776-4841

Underwriters Laboratories, Inc.
333 Pfingsten Road
Northbrook, IL 60062

APPENDIX E
School Bus
Operations

Appendix E

National Highway Traffic Safety Administration Highway Safety Program Guideline #17 PUPIL TRANSPORTATION SAFETY

- I. **Scope.** This guideline establishes minimum recommendations for a State Highway Safety Program for pupil transportation safety including the identification, operation and maintenance of buses used for carrying students; training of passengers, pedestrians and bicycle riders; and administration.
- II. **Purpose.** The purpose of this guideline is to minimize, to the greatest extent possible, the danger of death or injury to school children while they are traveling to and from school and school-related events.
- III. **Definitions.** “Bus” is a motor vehicle designed for carrying more than 10 persons (including the driver).
“Federal Motor Carrier Safety Regulations (FMCSR)” are the regulations of the Federal Motor Carrier Safety Administration (FMCSA) for commercial motor vehicles in interstate commerce, including buses with a gross vehicle weight rating (GVWR) greater than 10,000 pounds or designed to carry 16 or more persons (including the driver), other than buses used to transport school children from home to school and from school to home. (The FMCSR are set forth in 49 CFR Parts 383-399).
“School-chartered bus” is a “bus” that is operated under a short-term contract with state or school authorities who have acquired the exclusive use of the vehicle at a fixed charge to provide transportation for a group of students to a special school-related event.
“School bus” is a “bus” that is used for purposes that include carrying students to and from school or related events on a regular basis, but does not include a transit bus or a school-chartered bus.
- IV. **Pupil Transportation Safety Program Administration and Operations.**
Recommendation. Each state, in cooperation with its school districts and other political subdivisions, should have a comprehensive pupil transportation safety program to ensure that school buses and school-chartered buses are operated and maintained so as to achieve the highest possible level of safety.
- A. **Administration.**
1. There should be a single state agency having primary administrative responsibility for pupil transportation, and employing at least one full-time professional to carry out these responsibilities.
 2. The responsible state agency should develop an operating system for collecting and reporting information needed to improve the safety of operating school buses and school-chartered buses. This includes the collection and evaluation of uniform crash data consistent with the criteria set forth in Highway Safety Program Guidelines No. 10, “Traffic Records” and No. 19, “Accident Investigation and Reporting.”
- B. **Identification and Equipment of School Buses.** Each state should establish procedures to meet the following recommendations for identification and equipment of school buses.
1. All school buses should:
 - a. Be identified with the words “School Bus” printed in letters not less than eight inches high, located between the warning signal lamps as high as possible

without impairing visibility of the lettering from both front and rear, and have no other lettering on the front or rear of the vehicle, except as required by Federal Motor Vehicle Safety Standards (FMVSS), 49 CFR Part 571.

- b. Be painted National School Bus Yellow, in accordance with the colorimetric specification of National Institute of Standards and Technology (NIST) Federal Standard No. 595a, color 13432, except that the hood should be either that color or lusterless black, matching NIST Federal Standard No. 595a, Color 37038.
 - c. Have bumpers of glossy black, matching NIST Federal Standard No. 595a, Color 17038, unless, for increased visibility, they are covered with a reflective material.
 - d. Be equipped with safety equipment for use in an emergency, including a charged fire extinguisher, that is properly mounted near the driver's seat, with signs indicating the location of such equipment.
 - e. Be equipped with device(s) demonstrated to enhance the safe operation of school vehicles, such as a stop signal arm.
 - f. Be equipped with a system of signal lamps that conforms to the school bus requirements of FMVSS No. 108, 49 CFR 571.108.
 - g. Have a system of mirrors that conforms to the school bus requirements of FMVSS No. 111, 49 CFR 571.111, and provides the seated driver a view to the rear along both sides of the bus and a view of the front bumper and the area in front of the bus. Mirrors should be positioned and adjusted such that when a rod, 30 inches long, is placed upright on the ground at any point along a traverse line one-foot forward of the forward-most point of a school bus, at least seven 1/2 inches of the length of the rod should be visible to the driver, either by direct view or by the system of mirrors.
 - h. Comply with all FMVSS applicable to school buses at the time of their manufacture.
2. Any school bus meeting the identification recommendations of sections 1. a.-h. above, that is permanently converted for use wholly for purposes other than transporting children to and from school or school-related events, should be painted a color other than National School Bus Yellow, and should have the stop arms and school bus signal lamps described by sections 1. e. & f. removed.
 3. School buses, while being operated on a public highway and transporting primarily passengers other than school children, should have the words "School Bus" covered, removed, or otherwise concealed, and the stop arm and signal lamps described by sections 1. e & f should not be operated.
 4. School-chartered buses should comply with all applicable FMCSR and FMVSS.
- C. **Operations.** Each state should establish procedures to meet the following recommendations for operating school buses and school-chartered buses:
1. Personnel.

- D. **Vehicle Maintenance.** Each state should establish procedures to meet the following recommendations for maintaining buses used to carry school children:
1. School buses should be maintained in safe operating condition through a systematic preventive maintenance program.
 2. All school buses should be inspected at least semi-annually. In addition, school buses and school-chartered buses subject to the Federal Motor Carrier Safety Regulations of FMCSA should be inspected and maintained in accordance with those regulations (49 CFR Parts 393 and 396).
 3. School bus drivers should be required to perform daily pre-trip inspections of their vehicles, and the safety equipment thereon (especially fire extinguishers), and to report promptly and in writing any problems discovered that may affect the safety of the vehicles's operation or result in its mechanical breakdown. Pre-trip inspection and condition reports for school buses and school-chartered buses subject to the Federal Motor Carrier Safety Regulations of FMCSA should be performed in accordance with those regulations (49 CFR 392.7, 392.8, and 396).
- E. **Other Aspects of Pupil Transportation Safety.**
1. At least once during each school semester, each pupil transported from home to school in a school bus should be instructed in safe riding practices, proper loading and unloading techniques, proper street crossing to and from school bus stops and should participate in supervised emergency evacuation drills, which are timed. Prior to each departure, each pupil transported on an activity or field trip in a school bus or school-chartered bus should be instructed in safe riding practices and on the location and operation of emergency exits.
 2. Parents and school officials should work together to select and designate the safety pedestrian and bicycle routes for the use of school children.
 3. All school children should be instructed in safe transportation practices for walking to and from school. For those children who routinely walk to school, training should include preselected routes and the importance of adhering to those routes.
 4. Children riding bicycles to and from school should receive bicycle safety education, wear bicycle safety helmets, and not deviate from preselected routes.
 5. Local school officials and law enforcement personnel should work together to establish crossing guard programs.
 6. Local school officials should investigate programs which incorporate the practice of escorting students across streets and highways when they leave school buses. These programs may include the use of school safety patrols or adult monitors.
 7. Local school officials should establish passenger vehicle loading and unloading points at schools that are separate from the school bus loading zones.
- F. **Program evaluation.** The pupil transportation safety program should be evaluated at least annually by the state agency having primary administrative responsibility for pupil transportation.

SCHOOL BUS DRIVER APPLICATION
(Example of a form that may be used)

Applicant Name: _____

Present Address: _____

Date of Birth: _____ Social Security # _____

Addresses at which applicant has resided during the past three (3) years: _____

Current Driver's License Number: _____

State of Issue: _____ Expiration Date: _____

Class of License: _____ Endorsements: _____ Restrictions: _____

Have you had any type of vehicle accident in the last three (3) years? yes no

If yes, give dates and explain: _____

Have you ever been terminated or suspended from previous employment because of a positive drug or alcohol test?
 yes no

Have you been convicted of a moving traffic violation in the last three (3) years? yes no

If yes, give dates and explain: _____

Has your driver's license been suspended or revoked during the last three (3) years?
 yes no

If yes, give dates and explain: _____

Has your license ever been revoked, suspended or denied since the time you obtained your original license?
 yes no

If yes, give dates and explain: _____

Have you held a license in another state during the last three (3) years? yes no

Which state(s): _____

List the names and addresses of your current and previous employers during the ten (10) years preceding the date of this application:

Employer: _____

Address: _____

Dates: _____

Reason for leaving: _____

Job Title & Duties: _____

Employer: _____

Address: _____

Dates: _____

Reason for leaving: _____

Job Title & Duties: _____

Additional employers may be listed on a separate sheet.

Education and training (circle the highest obtained):

8 9 10 11 12 GED 13 14 15 16 17 18 19+

Degrees earned: _____

Specific experience of formal training related to transportation of pupils: I understand that the information provided by me, may be checked and previous employers may be contacted for the purpose of investigating my background. This certifies that this application was completed by me, and that all entries on it and information on it are true and complete to the best of my knowledge.

(Date) _____ (Signature) _____

I authorize the employer to conduct a criminal history check, and to investigate all written information contained on this application.

(Date) _____ (Signature) _____

ACTIONS TO BE TAKEN DURING AND FOLLOWING THE OBSERVATIONS OF SCHOOL BUS ROUTES

Supervisory actions that should be taken during and after the transportation director completes a review of bus routes are listed below:

1. Check the route and schedule for accuracy.
2. Determine that loading and unloading occurs only at authorized stops.
3. Check to see that vehicles are operated in compliance with prescribed regulations.
4. Observe the driver-pupil relationship.
5. Check loading and unloading conditions at school centers.
6. Check for evidence of supervision in loading zones.
7. Note hazardous road conditions.
8. Note the nature, frequency and locations of bus stop law violations.
9. Observe conditions of bus (e.g., cleanliness, tires, windows, emergency exit(s), first aid kits, fire extinguisher, seats, etc.).
10. Observe vehicle inspection guide for evidence of pre-trip inspection.
11. Note driver attitude toward other motorists and pedestrians.
12. Follow the observation with a written report and discussion with the driver (and others, as appropriate).
13. File the written report in the driver's permanent record.

GUIDELINES FOR EN ROUTE EMERGENCY BUS EVACUATION PROCEDURES

The intent of this procedure is to provide guidelines for evacuating a bus only when absolutely necessary for the safety of students and staff in an emergency situation.

I. Preparing an Emergency Evacuation Plan:

Bus staff should have an emergency evacuation plan in the bus which considers the individual capabilities and needs of each student, the type of behavior which might be exhibited during an emergency evacuation, and the type of wheelchair or support equipment being used for students. A floor plan with pupil location and special needs should be on the bus. Some issues to consider in establishing an evacuation plan are listed:

- A. Which students could help, and to what extent.
- B. How to deal with individual emergencies during the evacuation process, such as seizures.
- C. Whether students should be evacuated in their wheelchairs, or removed from their wheelchairs before evacuation.
- D. How to disconnect or cut wheelchair securement and occupant protection equipment, including belts, trays, and other support equipment.
- E. Identify which students might run after evacuation so they could be evacuated last.
- F. Know the length of time a student requiring life support equipment or medical care procedures can survive if such service is interrupted or delayed during the evacuation process.

Every driver and/or attendant should be able to physically carry out their emergency evacuation plan upon request without hesitation. Many emergencies allow only 3 to 5 minutes to complete an evacuation before possible serious injury to students might occur.

II. Assessing the Need to Evacuate:

Student safety and control are best maintained by keeping students on the bus during an emergency and/or impending crisis situation if doing so does not expose them to unnecessary risk or injury. A decision to evacuate should include consideration of the following conditions:

- A. Is there a fire involved?
- B. Is there a smell of raw or leaking fuel?
- C. Does the possibility exist that the bus will roll/tip causing further threat to safety?
- D. Is the bus likely to be hit by other vehicles?
- E. Is the bus in the direct path of a sighted tornado or other natural disasters such as rising water?
- F. Would evacuating students expose them to speeding traffic, severe weather or a dangerous environment?

- G. Considering the medical, physical and emotional condition of the students, does staying on the bus or evacuating pose the greater danger to the students' safety?

III. General Procedures to Follow for Emergency Evacuation:

- A. Keep the situation as orderly and low-key as possible.
- B. If time and conditions permit, the bus driver should use the communication system to advise the office of the following information:
 - 1. The exact location, including nearest intersecting road or familiar landmark.
 - 2. The condition creating the emergency.
 - 3. The type of assistance needed (police-fire-ambulance).
 - 4. Notification that the bus is being evacuated.
- C. Analyze conditions to determine safest the exit from the bus.
- D. During evacuation, monitor conditions and adjust procedures to meet unexpected circumstances.
- E. Move evacuated students to the nearest safe location at least 100 feet from the bus.
- F. Be prepared to give information to emergency medical personnel regarding individual students' medical or physical requirements.

IV. Equipment Considerations:

- A. Bus staff should, as part of their pre-trip inspection, familiarize themselves with the location and method of opening all emergency exits.
- B. If time permits, a lift platform can be lowered half the distance to the ground, providing a step for evacuating wheelchairs. If there is a smell of spilled fuel, the lift should be operated manually.
- C. When re-entry to the bus is not probable, communication equipment and first aid kits can frequently be passed through a window, making them accessible outside the bus. Consideration should also be made for student medication, if carried and needed.
- D. If a large bus is being used and evacuation is made through the rear exit door, consideration should be given to the method to be used for re-entry to the bus, if necessary, considering the height of the floor from the ground. Some states allow a stirrup-type step on the rear bumper.
- E. If a battering ram is needed, a fire extinguisher can often serve that purpose.
- F. A belt cutter should be stored in the bus in a location readily accessible to the driver. The cutter should have a protected mouth to restrict the entry of fingers, etc.

V. Local District Policy:

Bus staff should be familiar with local district policy regarding:

- A. Evacuation procedures to follow when enroute and a tornado or flash flood, etc. is sighted, with no shelter near.
- B. The type of medical information to be available on long distance trips in case of student injury.

NOTE: THE SAFETY OF THE BUS AND EQUIPMENT IS SECONDARY TO THE SAFETY OF THE STUDENTS. NO ATTEMPT SHOULD BE MADE TO SAVE EQUIPMENT OR PERSONAL ITEMS UNTIL ALL STUDENTS ARE REMOVED FROM THE BUS SAFELY, ARE OUT OF DANGER AND SUPERVISED.

Sample Crash Reporting Form School Bus Physically Involved

1. Type of Crash

<input type="checkbox"/> Between motor vehicles	<input type="checkbox"/> Fixed object
<input type="checkbox"/> Non-collision pedestrian	<input type="checkbox"/> Pedalcycle
<input type="checkbox"/> Railroad train	<input type="checkbox"/> Other collision

2. Complete if Fixed Object Crash

<input type="checkbox"/> Embankment	<input type="checkbox"/> Sign
<input type="checkbox"/> Utility pole	<input type="checkbox"/> Guardrail
<input type="checkbox"/> Tree	<input type="checkbox"/> Bridge rail
<input type="checkbox"/> Fence	<input type="checkbox"/> Median barrier
<input type="checkbox"/> Fire hydrant	<input type="checkbox"/> Curb or wall
<input type="checkbox"/> Culvert or head wall	<input type="checkbox"/> Parked vehicle

3. Did Crash Result In

<input type="checkbox"/> Fatality	<input type="checkbox"/> Non-incapacitating injury(moderate)
<input type="checkbox"/> Incapacitating injury (serious)	<input type="checkbox"/> Possible injury (minor)
<input type="checkbox"/> Property damage only (no one was killed or injured, but property damage equaled or exceeded \$500)	

4. Manner of Collision Between Vehicles or Objects

<input type="checkbox"/> Angle	<input type="checkbox"/> Rear-end
<input type="checkbox"/> Head-on	<input type="checkbox"/> Broadside
<input type="checkbox"/> Other	

5. Bus Direction Analysis

Collision with Pedestrian

<u>Intersection</u>	<u>Non-Intersection</u>
<input type="checkbox"/> Bus going straight	<input type="checkbox"/> Bus going straight
<input type="checkbox"/> Bus turning right	<input type="checkbox"/> Bus turning right
<input type="checkbox"/> Bus turning left	<input type="checkbox"/> Bus turning left
<input type="checkbox"/> Bus backing	<input type="checkbox"/> Bus backing
<input type="checkbox"/> Other action	<input type="checkbox"/> Other action

Collision with other vehicle

<u>Intersection</u>	<u>Non-Intersection</u>
<input type="checkbox"/> Entering at angle, both moving	<input type="checkbox"/> Same direction, both moving
<input type="checkbox"/> Entering same direction direction both moving	<input type="checkbox"/> Opposite direction both moving
<input type="checkbox"/> Entering opposite direction both moving	<input type="checkbox"/> One vehicle stopped
<input type="checkbox"/> All Other Collisions	

Intersection

- _____ Fixed object
- _____ Other road vehicle, train, pedal cycle
- _____ Other object, animal

Non-Intersection

- _____ Fixed object
- _____ Other road vehicle, train, pedal cycle
- _____ Other object, animal

Non-Collision

Intersection

- _____ Overturn
- _____ Other non-collision

Non-Intersection

- _____ Overturn
- _____ Other non-collision

6. First Point of Impact (Diagram on state collision report)

7. Contributing Circumstances

Driver Action

- _____ Speed
- _____ Failed to yield right-of-way
- _____ Passed stop sign
- _____ Disregarded signal
- _____ Drove left of center
- _____ Improper overtaking
- _____ Made improper turn
- _____ Followed too closely
- _____ Backing
- _____ Sudden movement
- _____ Improper distance judgment
- _____ No improper action

Other Driver

- _____ Speed
- _____ Failed to yield right-of-way
- _____ Passed stop sign
- _____ Disregarded signal
- _____ Drove left of center
- _____ Improper overtaking
- _____ Made improper turn
- _____ Followed too closely
- _____ Backing
- _____ Sudden movement
- _____ Improper distance judgment
- _____ No improper action

8. Other factors

- _____ Roadway
- _____ Defective surface
- _____ Slippery
- _____ Inoperative Traffic Signal
- _____ View obstructed by object
- _____ No vehicle defect

- _____ Vehicle Defect
- _____ Tires
- _____ Brakes
- _____ Lights
- _____ Steering
- _____ Other

9. Total number of lanes on roadway? _____

10. Posted speed limit? _____

11. Approximate speed of the bus? _____

12. Was bus driver's lap belt in use when the crash occurred? _____

13. School bus use at time of crash Yes No

- _____ Regular route
- _____ Field/activity trip

- _____ Special education use
- _____ Other use

14. Condition of road at time of crash
- | | |
|--|---------------------------------------|
| <input type="checkbox"/> Dry | <input type="checkbox"/> Under Repair |
| <input type="checkbox"/> Icy | <input type="checkbox"/> Snow packed |
| <input type="checkbox"/> Holes or ruts | <input type="checkbox"/> Muddy |
| <input type="checkbox"/> Wet | <input type="checkbox"/> Other |
15. Light Condition
- | | |
|-----------------------------------|---|
| <input type="checkbox"/> Dawn | <input type="checkbox"/> Dark (lighted) |
| <input type="checkbox"/> Daylight | <input type="checkbox"/> Dark (not lighted) |
| <input type="checkbox"/> Dusk | |
16. Weather condition
- | | |
|-------------------------------------|----------------------------------|
| <input type="checkbox"/> Clear | <input type="checkbox"/> Raining |
| <input type="checkbox"/> Sleet | <input type="checkbox"/> Fog |
| <input type="checkbox"/> Snowing | <input type="checkbox"/> Dust |
| <input type="checkbox"/> Smog/Smoke | <input type="checkbox"/> Other |

Loading/Unloading Crash

1. At the time of the crash, where was the bus?
- | | |
|---|---|
| <input type="checkbox"/> Approaching the zone | <input type="checkbox"/> Leaving the zone |
| <input type="checkbox"/> Stopped in the zone | <input type="checkbox"/> Not in sight |
2. Was the passenger(s)
- | | |
|-------------------------------------|--|
| <input type="checkbox"/> Hit by bus | <input type="checkbox"/> Hit by other vehicle? |
|-------------------------------------|--|
3. Number injured (See Injury Tally Sheet) _____
4. Location of injured pupil(s)
- | | |
|--|-------------------------------------|
| <input type="checkbox"/> On side of road | <input type="checkbox"/> In roadway |
| <input type="checkbox"/> On sidewalk | <input type="checkbox"/> Other |
5. Description of behavior of pupil(s) _____

6. Description of crash _____

7. Diagram of crash
Complete the following diagram showing direction and position of vehicles involved, designating clearly the point of contact. (If this diagram will not serve for the accident in question, use adjacent space provided).

Diagram of crash

Complete the following diagram showing direction and position of vehicles involved, designating clearly the point of contact. (If this diagram will not serve for the crash in question, use adjacent space provided).

INDICATE BY ARROW
DIRECTION OF NORTH

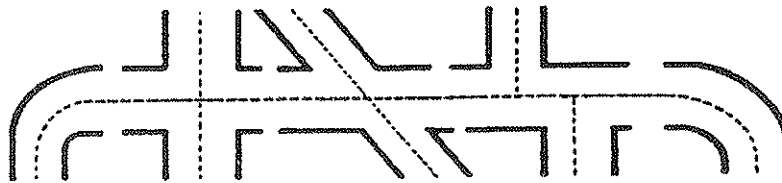

Injury Tally Sheet

1. Ages and injury severities for all persons on bus? _____
2. Ages and injury severities for person(s) not on the bus, in loading/unloading area? _____

SCHOOL TRANSPORTATION-RELATED PERSONNEL

Age	On Board Bus									Off Bus Loading/Unloading Area								
	Killed			Injured			Killed			Injured								
	M	F	All	Serious	Moderate	Minor	M	F	All	Serious	Moderate	Minor						
Under 5	01	02	03		04	05		06	07	08		09		10				
5	11	12	13		14	15		16	17	18		19		20				
6	21	22	23		24	25		26	27	28		29		30				
7	31	32	33		34	35		36	37	38		39		40				
8	41	42	43		44	45		46	47	48		49		50				
9	51	52	53		54	55		56	57	58		59		60				
10	61	62	63		64	65		66	67	68		69		70				
11	71	72	73		74	75		76	77	78		79		80				
12	81	82	83		84	85		86	87	88		89		90				
13	91	92	93		94	95		96	97	98		99		100				
14	101	102	103		104	105		106	107	108		109		110				
15	111	112	113		114	115		116	117	118		119		120				
16	121	122	123		124	125		126	127	128		129		130				
17	131	132	133		134	135		136	137	138		139		140				
18	141	142	143		144	145		146	147	148		149		150				
Over 18	151	152	153		154	155		156	157	158		159		160				
Driver	161	162	163		164	165		166	167	168		169		170				
Others	171	172	173		174	175		176	177	178		179		180				
Totals	181	182	183		184	185		186	187	188		189		190				

REPORT SUBMITTED BY: _____

Signature _____

Name (Print) _____

Date _____

Position _____

4. Whenever possible, separate pickup and delivery points some distance from the teacher, student parking areas should be designated for parents, delivery, service, teacher and administrative traffic. Accident inducing conditions are created by haphazard pickup and delivery of pupils in the bus loading zones, particularly during inclement weather.
5. Whenever possible, roads should not be constructed that completely encircle a school. Areas that pupils must cross to engage in outside activities should be free of all vehicular traffic.
6. All school bus roads entering into or exiting from main arteries should have a 50- to 100-foot-radius turn on the inner edge of pavement. Within the school site, roads should have at least a 60-foot radius on inner edge of pavement on all curves. At least a 50-foot tangent section should be provided between reverse curves. In order to minimize driveway entrance and exit widths, island construction may be required. Driveway openings must conform to local requirements. Driveway openings on state highways should be approved by the state highway department.
7. Curbing, with suitable drainage, should be constructed on all roads utilized by school buses within the school site. Consideration should be given to state highway department performance specifications. A minimum of 30 feet should be maintained for one-way traffic and 36 feet for two-way traffic. Roads should be wider on all curves.
8. It is desirable to separate all parking areas, it might be advantageous if only the visitor parking area were located in close proximity to the school. Care should be exercised in the placement of these areas to preclude the visitor from crossing the school bus traffic pattern.
9. In the Construction of parking areas, it might be advantageous if only the visitor parking area were located in close proximity to the school. Care should be exercised in the placement of these areas to preclude the visitor from crossing the school bus traffic pattern.
10. Prior to designing and laying out roads and parking lots, architects should consult with the school administration on the following items:
 - a. Total number of pupils and school personnel.
 - b. Number of present and projected pupils to be transported.
 - c. Number of buses.
 - d. Type of schedule.
 - (1) Staggered opening and closing times.
 - (2) Single opening and closing times.
 - e. Extra-curricular activities that would necessitate use of school buses.
11. It is desirable to locate parked buses on school grounds to prevent glare from reflective surfaces of windows, doors and windshields from being transmitted to the pupils in the classroom.
12. Attention should be given in planning school bus parking, loading and unloading areas. Parking should exclude the necessity for backing the bus.
13. Sidewalk plans for pupils walking to school should eliminate crosswalks in front of the buses.

14. Architects' plans for school buildings often include bus canopies. Such units are not considered feasible for schools with large enrollments. Canopies are advantageous in schools attended by pupils with disabilities. Height of the canopy should accommodate the highest school buses. Each canopy support post adjacent to the driveway curb should have a three-foot minimum setback from the curb to minimize the possibility of crushing a pupil between the support post and arriving school buses.
15. For areas that will be constantly utilized by heavy school buses, the type of pavement and base should conform to state highway department specifications.
16. All roads within the school site should be graded to avoid configurations that could impair a motorist's vision. It is suggested that a maximum 5% grade be allowed on all roads and, at entrance and exit points, a maximum 2% grade be allowed. Blind corners and intersections should be eliminated. Trees and shrubbery planted on the school site should not obstruct a motorist's vision.
17. Plans for the location of access and service roads should exclude conditions that would require school buses to be backed on the school premises.
18. Safety at all pupil loading and unloading areas should be considered and provided on the school site.
19. Plans for loading facilities should include separate areas specially designed for pupils with disabilities. Attention should be given to entrance ramps and handrails.
20. Plans for roads and loading areas should accommodate emergency vehicles which must have access to the school at all times.
21. Where necessary, traffic control devices should be provided to assist school traffic to enter regular flow.

**Identification and Evaluation
of
School Bus Route and Hazard Marking Systems**

Final Report

**Work Performed Under a Grant From
The National Highway Traffic Safety Administration
U.S. Department of Transportation**

**Grant # DTNH22-97-G-05155
June 1998**

National Association of State Directors of Pupil Transportation

**116 Howe Drive
Dover, DE 19901**

**Identification and Evaluation of School Bus Route and Hazard Marking Systems NHTSA
Grant # DTNH22-97-G-05155
National Association of State Directors of Pupil Transportation**

Background:

An estimated 23 million public school students ride over 400,000 school buses twice daily to go to and from school. Additionally, it has been estimated that another one to two million students ride school buses to and from school-related activities each day. In the course of a school year, school buses transport students over four billion miles. The safety of pupil transportation is of significant concern to Federal, State and local governments, school districts, school administrators, parents, and the general public.

Within the school transportation industry itself, there is a long history of significant efforts to make school transportation safe and efficient. Pupil transportation programs date back to the earliest years of the 20th century. By 1910, thirty states had pupil transportation programs in place. The first "vehicles" used to transport students were nothing more than horse-drawn carts which were borrowed from local farmers. With the development of automobiles and trucks with gasoline-powered engines, the school "wagon" was replaced with the school "truck." During the 1920's and 1930's, the Nation's roadway system was expanding, especially in rural communities. This led to a greater need for vehicles to transport schoolchildren and the formation of an industry of school bus manufacturers.

As the number of school buses operating on the roadways increased, there came the inevitable problems. Several serious tragedies occurred involving school buses which caused school officials to think seriously about developing safety guidelines for school buses. In 1939, representatives from 48 states gathered to develop recommendations for school buses. Since that time, there have been a total of 12 National Conferences on School Transportation where representatives from each state gather to revise existing and establish new safety guidelines for school buses and operating procedures for the safe transportation of schoolchildren, including those with disabilities. The product of these national conferences are referred to as the National Guidelines for School Transportation. The National Conferences are jointly sponsored by the National Association of State Directors of Pupil Transportation Services (which includes the School Bus Manufacturers Technical Council), the National Association for Pupil Transportation, and the National School Transportation Association, the National Safety Council, and Central Missouri State University.

To help ensure the transportation safety of students on school buses, the National Highway Traffic Safety Administration (NHTSA) establishes and enforces a series of Federal Motor Vehicle Safety Standards governing the safety performance and manufacture of school buses. NHTSA also conducts a safety defects investigation program to identify safety defects in motor vehicles, including school buses, and requires manufacturers to recall and remedy defective vehicles free of charge. In addition, NHTSA's Guideline #17, "Pupil Transportation Safety," establishes minimum recommendations for a pupil transportation safety program, including the identification, operation, and maintenance of buses used for transporting students; training of passengers, pedestrians, and bicycle riders; and administration.

Even with the school bus-specific Federal Motor Vehicle Safety Standards, NHTSA's safety defect investigation and recall program, NHTSA's Guideline #17, and the school transportation industry's National Guidelines for School Transportation, a few school bus safety problems continue to persist. One of these problems was identified as a contributing factor in a tragic crash that occurred on October 25, 1995, in Fox River Grove, Illinois. On that day, a commuter train hit a school bus that was stopped at a highway-railway grade crossing. Seven students were killed and the school bus driver and 24 other students were injured. The school bus driver had taken all of the appropriate actions prior to crossing the railroad tracks, but unknowingly failed to completely clear the railway track while the school bus was stopped at a red traffic light. The commuter train struck the rearmost side of the school bus.

At the conclusion of its investigation of the crash, the National Transportation Safety Board identified one of the factors contributing to the crash as an inadequate school district routing and hazard marking system. The Safety

Board noted that the substitute school bus driver operating the bus that day was unaware of the hazard at the highway-railroad crossing because “the methods employed by the school district to identify and evaluate route hazards were ineffective.”

In addition to the Safety Board’s investigation of the Fox River Grove crash, the U.S. Department of Transportation formed a Grade Crossing Task Force to review the decision-making process for designing, constructing, and operating rail crossings. The Task Force published its findings in a March 1996 report, “Accidents That Shouldn’t Happen.” One recommendation from that report calls for NHTSA to “work with State directors of pupil transportation, through relevant national organizations, to develop a system to improve school bus routing safety by focusing on highway-railroad grade crossings.”

As a result of the recommendations from the Safety Board and the Grade Crossing Task Force, NHTSA provided a grant to the National Association of State Directors of Pupil Transportation to:

1. Research the issue of school bus route hazards and route hazard marking systems;
2. Develop a set of guidelines that school transportation officials could utilize in developing a system for identifying school bus route hazards that meets the needs of their locality;
3. Provide suggestions for reasonable and appropriate means of informing school bus drivers of potential school bus route hazards so as to educate them on how to deal with any route hazards that can not be avoided; and
4. Suggest methods to disseminate the information developed during this project to the school transportation community.

School Bus Driver Training:

School bus driver training is one of the most important components of the school bus transportation system. A critical component of school bus driver training is the recognition of potential driving hazards and appropriate adjustment of driving behavior to ensure the safety of the school bus occupants. The goal of this project and report is to provide school bus drivers and substitute drivers with a list of locations/situations that should be recognized as being potentially hazardous. School bus drivers should be properly trained to deal with these potentially hazardous conditions. In addition, school bus drivers should be trained to deal with hazardous conditions that occur suddenly or are of a temporary nature. Constant dialogue between school bus drivers and route planners is critical to ensure the continued safe transportation of students in school buses.

Methodology:

The National Association of State Directors of Pupil Transportation undertook the following activities to develop a school bus route hazard identification system and a means of educating school bus drivers about such hazards. Each of the activities included review and comment by the various state directors of pupil transportation. Throughout this report, specific comments from states are included to illustrate the involvement and insight provided by the state directors.

1. Define School Bus Route Hazard

The first, and most critical, step was to develop an acceptable and reasonable definition of what constitutes a “school bus route hazard.” From a practicable perspective, “school bus route hazards” can be grouped into two distinct categories. First, there are “driving hazards” that are encountered while operating a school bus route, such as railroad grade crossings and industrial intersections. Second, there are “school bus loading zone hazards” that are encountered at a school bus stop, such as a narrow, busy street without sidewalks or dangerous curves that do not

provide the school bus driver, the students, or other motorists with an adequate view of the school bus loading zone. The scope of work for this project only included the first category of school bus route hazards - driving hazards.

2. Develop a “Model” School Bus Route Hazard Identification System

Based on the knowledge and expertise of individuals within the school transportation industry, an ideal program that could be used to assist states and local school districts in identifying and evaluating potential school bus route hazards was defined. This ideal program became the “model” against which existing school bus route hazard identification programs were compared.

3. Review Existing Materials/Information

Examples of existing state or local school district route hazard identification programs were reviewed and compared with the “model” system described above. The existing programs were reviewed in terms of the ability of the program to identify route hazards and communicate that information to the appropriate individuals.

4. Develop a Recommended System

Based on the review of existing programs, as compared to the “model” system, a recommended school bus driving route hazard identification system was developed that could provide states and local school districts with an efficient method for identifying potential school bus route hazards and a means of communicating information about those hazards to school bus drivers and trainers, route planners, and other appropriate school transportation officials.

5. Dissemination Approaches

Finally, suggestions were made on how to disseminate the “recommended” system to the school transportation community, and what approaches should be taken to educate state and local school transportation providers on the importance of adopting such a school bus driving route hazard identification system.

Results of Program Activities:

Result #1 — Definition of a School Bus Route Driving Hazard

While it is possible to develop a list of the potential hazardous locations/situations that a school bus driver could encounter in the course of driving a school bus route, it is not possible to develop a definitive list of every potential driving hazard. As was pointed out by the state of Indiana during discussions of this project, “Regular review of the route hazards list is encouraged. This will keep the document accurate and permit the addition of ‘yet-to-be-discovered’ hazards.”

Some potential school bus route driving hazards can be considered as “fixed,” in that the situation or condition exists (such as a railroad crossing), can be identified, and drivers can be informed and educated about the potential hazard. Other potential driving hazards occur without advanced warning — examples include: (1) inclement weather conditions, such as fog, sand storms, blinding sunlight, snow storms, etc.; (2) conditions that result from weather conditions, such as flooded roadways, fallen trees, downed power lines; and (3) accident locations. This report focuses on potential school bus route driving hazards that are of a “fixed” nature.

Discussion:

Table 1 details many of the potentially hazardous locations/situations that a school bus driver could encounter in the course of driving a school bus route. These potential driving hazards were selected based on the belief that the mere existence of any one of these conditions poses possible serious consequences if the school bus driver is not aware of the existence of the hazard. While a hazard could develop at any time while driving a school bus (for example, a tree could fall across a road during a storm, or a stream could overflow, or a wet road could suddenly ice over), this list defines only fixed conditions that, by their presence, have been deemed a potential driving hazard. Also, this list is limited to the hazardous locations/situations encountered while driving the school bus, not during loading and unloading operations.

For each potential school bus route driving hazard, a list of factors or situations that could contribute to causing the hazard is provided. It is important to remember that this list of potential school bus route driving hazards, and the factors/situations within them, is not “all-inclusive.” States and local school districts may encounter factors and situations that are not listed in Table 1, but which they deem are potentially hazardous.

Table 1.

List of Potentially Hazardous Locations/Situations on School Bus Routes

Railroad Grade Crossing

- * Number of tracks
- * Visual obstructions to determine type and travel speeds of trains
- * Train schedules (consider unscheduled trains also)
- * Presence or absence of grade crossing controls
- * Unique characteristics or operation of grade crossing controls
- * Presence or absence of traffic control signals, including interaction with grade crossing controls
- * Size of queuing area before and after the tracks
- * Expected traffic conditions at various times during the day
- * Roadway design near the grade crossing

Dangerous Intersections and Roadways

- * High-frequency crash locations as defined by state transportation and/or law enforcement officials
- * Uncontrolled intersections
- * Curves and intersections with limited sight distances
- * Areas with no shoulders
- * Visibility of traffic control signals
- * Coordination of traffic control signals with others in the immediate area

Bridges, Tunnels/Underpasses and Overpasses

- * Weight capacity
- * Height clearances
- * Lane width

Queuing/Storage Areas

- * Short acceleration/deceleration lanes
- * Limited median areas crossing multi-lane highways
- * Turning lanes

Industrial Intersections and Construction Zones

- * Areas where heavy vehicles/equipment operate on a regular basis, and may be entering, exiting, or crossing the roadway

Steep Downgrades

- * Mountainous areas where brake condition and braking operations are important
- * Location of out-of-control vehicle run-off areas

Areas of Significant Speed Differential Between Vehicles

- * On-off ramps to high-speed roads
- * Farm vehicle areas, including non-motorized vehicles on the road
- * Mountain terrain

Pedestrian Areas

- * School bus loading/unloading zones
- * Narrow streets with parked motor vehicles - children darting between vehicles
- * Congested shopping and business areas

Other Conditions Identified in Local Area

1. Unique roadway locations, for example:
 - a. Roadways without guardrails that are next to rivers, lakes, etc.
 - b. Dirt or gravel roads that could affect braking
 - c. Rock quarry or open pits
 - d. Areas with problems related to right-turn-on-red laws
 - e. Areas with visibility problems due to air quality/industrial smoke/etc.
 - f. Areas where emergency equipment operate on a regular basis
 - (1) fire stations
 - (2) hospitals

Result #2 - Development of a "Model" School Bus Route Hazard Identification System

During the course of this project, a "model" school route hazard identification system was outlined. It was recognized that such a system would consist of three major components:

1. A list of potential driving hazards;
2. A specified procedure/schedule for conducting on-site reviews of school bus routes; and
3. An efficient and effective means of informing school bus drivers of the presence of potential driving route hazards.

Of the three components, the first was determined to be the most critical, since without a definition of what constitutes a school bus route driving hazard, the other components would have little utility. Additionally, developing a procedure and schedule for reviewing school bus routes and an information dissemination plan were viewed as administrative policy decisions that were independent of the technical issues related to identifying potential school bus route driving hazards. Accordingly, the focus of the effort was placed on identifying and listing potential school bus route driving hazards.

An initial list of potential hazards was prepared during a Working Session of state directors during the 1997 annual conference of the National Association of State Directors of Pupil Transportation Services. The results of that session were summarized and provided for review to all state directors of pupil transportation. The final results of that effort are discussed in the previous section of this report, "Result #1 - Definition of a School Bus Route Driving Hazard."

Result #3 — Review of Existing Materials/Information

A review of existing school bus route hazard identification systems was made to see if any system assessed all of the potential driving hazards developed during the Working Session at the 1997 annual conference. Not one was found. However, this effort identified additional potential hazards that were not previously considered, but were ultimately included in the final list of school bus route driving hazards as defined in Result #1 above.

Result #4 — Defining a Route Hazard Identification System

The major goal of this project was to develop a system that a state or a local school district could use to:

- * Identify any fixed locations/situations that constitute a potential school bus driving hazard; and

- * Inform school bus drivers and substitute drivers of each identified potential route hazard on the school bus route(s) they drive.

Identification

The first component of such a system would consist of an established, systematic process to evaluate all school bus routes to determine whether any potential fixed driving hazards exist. An annual review of each school bus route by a person trained to identify potential route driving hazards would provide the basis for identifying any potential hazards. In addition, school bus drivers should be trained in how to recognize a potential school bus route driving hazard, and to report any new potential hazardous conditions to the appropriate school transportation officials. In effect, this would provide for continual monitoring and review of school bus routes so school bus drivers are aware of all potential fixed driving hazards on their routes. As stated by Connecticut, "constant communication between school bus drivers and route planners is critical to safety." Hazards can and do change, even on a daily basis. As such, "daily updates of critical route hazards should be foremost in the minds of dispatchers and drivers."

A checklist format based on the above list of potential school bus driving route hazards (Result #1 — Table 1) would provide for a consistent means of ensuring that such items were considered during the review of each school bus route. An example of such a checklist for the items identified in Result #1 appears as Appendix A to this report,* and is based on a format utilized in Oklahoma. It is important to remember that a state or a local school district should ensure that any potential hazards that may be unique to their area, or any potential hazards that they believe were missing, are added to the checklist. In addition to regular school bus routes, there also can be potential driving hazards along routes taken for field trips or extra-curricular activities. In such cases, drivers may be able to identify potential route driving hazards based on their personal knowledge of the route or on a previous trip to the same location.

Information

The second component of a school bus route driving hazard identification system consists of a means of informing all regular and substitute school bus drivers of the potential driving hazards on their school bus route(s). New Jersey stressed the importance of "the need for drivers and driver trainers to make clear notes of these hazards for all substitute drivers."

In addition to the drivers, school bus route planners/schedulers/dispatchers, etc. should be made aware of all information about potential driving hazards on the school bus routes. This information would allow them to make changes or adjustments to the routes, when reasonable and practicable, so as to minimize or eliminate the exposure of school buses to these route driving hazards.

Informing the necessary people about potential school bus route driving hazards can be accomplished in a number of ways. The most practical, and possibly most easily understandable, appears to be through the use of a map that is visually annotated to identify potential route hazards. The same map could obviously be used for other purposes, including designating the actual school bus route and student pickup/drop off locations. Additionally, as the states of Ohio and Virginia noted in their comments to this project, information on the location of police/fire/rescue stations, hospitals, and other emergency care facilities, and "possible 'safe stops' where a school bus may pull off the road and await aid in the event of an emergency" could be added to the map.

A number of local school districts currently use mapping techniques to document the streets in their district, the location of the students' homes, the school bus stops, and the routes traveled by school buses. Inexpensive color printers allow school districts to print color maps of their bus routes, and computer software allows route planners to incorporate custom information, such as route hazards, on the map.

Whatever means is chosen, it is important that school bus drivers be provided with route hazard information in a standardized, consistent manner. Also, the route hazard information should be available to the school bus driver every day, no matter which school bus is driven on that day.

Training

While not a specific part of this project, the importance of training school transportation providers about school bus route driving hazards can not be understated. In their comments, Ohio noted that the contents of a route hazard identification system are "only good if utilized." In other words, if drivers are not made aware of the potential driving

* Report being quoted above, checklist found in the appendix following.

hazards and trained on how to deal with such potential hazards, then no benefits will accrue from efforts to identify potential route hazards. Mississippi commented that its training in route hazards constantly works “to instill in each driver the concept of Expect the Unexpected.”

However, training alone does not guarantee success. As Connecticut stated, “Route hazards is an area in which some training can be afforded, but common sense and Page networking among drivers, local officials, and school district personnel is paramount to a safe and successful route hazard notification program.”

Result #5 - Dissemination Approaches

Based on the belief that the ultimate success of a school bus route driving hazard identification system is dependent on the awareness and use of the system by school transportation providers, it is strongly suggested that the results of this project be provided to all state directors of pupil transportation, the appropriate student transportation officials in each school district, and organizations affiliated with private/parochial schools. The dissemination to state directors and public schools districts could be made by use of direct mailings. The dissemination to private/parochial schools could be made through national associations that represent such schools.

As a supplement to direct mailings, the report on this project should be made available on the NHTSA and various school transportation web sites in a form that can be downloaded. In addition, the results of this project should be publicized through the various media that deal with pupil transportation.

Non-Fixed School Bus Route Hazards:

As mentioned earlier, this project only dealt with school bus route driving hazards that are “fixed.” However, it is recognized that other driving hazards can occur without advanced warning. These often result from inclement/adverse weather conditions or poor visibility conditions. It is important for school bus drivers to be aware of such possibilities and be trained on how to deal with such sudden potential hazards. As an example of some non-fixed driving hazards, Iowa includes in its School Bus Driver’s Handbook procedures to follow should a school bus encounter a tornado or Agri-Chemical clouding along school bus routes. Also, Delaware provides drivers with information in its School Bus Driver’s Handbook to prepare them for the following:

Adverse weather conditions

- * Extreme
- * Extreme heat
- * Rain
- * Fog
- * Snow/ice

Conditions affecting visibility

- * Sun glare
- * Darkness
- * Curves and hills

Wild animals are another example of a non-fixed school bus route driving hazard. In many rural and suburban areas, animals such as deer and live stock can be a serious danger to motorists. School bus drivers should be made aware of such situations and learn how to deal with them.

Conclusions:

Recognizing the importance of identifying school bus route driving hazards, the National Association of State Directors of Pupil Transportation Services has conducted this study for the National Highway Traffic Safety Administration. Verbal and written information from members of the Association was consolidated to focus on the key

issues and the best approach for addressing the problem of driving hazards on school bus routes. The following conclusions were reached during the study:

- * Driving hazards can and do exist on school bus routes.
- * Driving hazards on school bus routes that are of a “fixed” nature can be identified.
- * School transportation officials should establish a program to routinely and systematically evaluate all school bus routes for potential driving hazards.
- * A list of potential fixed school bus route driving hazards has been developed for use in evaluating school bus routes.
- * Information on potential school bus route driving hazards should be provided to all regular and substitute school bus drivers, route planners, dispatchers, and other appropriate personnel.
- * School bus drivers should be trained on how to effectively deal with potential school bus route driving hazards, of both a fixed or sudden nature.

The results of this project should receive wide dissemination.

The National Association of State Directors of Pupil Transportation encourages states, local school districts, and private/parochial schools to review this report in conjunction with their school transportation operations and take whatever actions are necessary to ensure that school bus route driving hazards are identified and made known to all appropriate school bus drivers and school transportation personnel.

(Reference Table 1 Report)
Appendix A
Checklist for Identifying Potential School Bus Route
Fixed Driving Hazards

Railroad Grade Crossings

Railroad Grade Crossing Identification Number: _____

Location: _____

How many tracks are present? _____

What are the times of the scheduled trains? _____

What types of trains use the track? Passenger _____ Freight _____ Commuter _____

What are the travel speeds of the scheduled trains? _____

	Yes	No
* Are the regulatory signs (crossbucks) clearly visible?	_____	_____
* Are there regulatory devices (lights/gates/bells) present?	_____	_____
* Are there any unique characteristics to the operation of the crossing controls?	_____	_____

What are they? _____

* When stopped approximately 15 feet from the nearest railroad track, is there an unobstructed sight distance of approximately 1,000 feet in both directions?	_____	_____
* Is there at least enough room on the other side of the furthest railroad track for the largest school bus to stop without encroaching on the train's right-of-way?	_____	_____
* Are there any roadway design features that could affect the safe operation of a school bus at the railroad crossing?	_____	_____

What are they? _____

Dangerous Intersections and Roadways

Location _____

	Yes	No
* Is this a high-frequency crash location?	_____	_____

	Yes	No
* Are traffic control devices present?	_____	_____
* Are there visibility obstructions?	_____	_____
What are they?	_____	

* Are there areas with no shoulders?	_____	_____
* Are there peculiar roadway features?	_____	_____
What are they?	_____	

Bridges, Tunnels/Underpasses and Overpasses

Location _____	Yes	No
* Is the weight capacity of the bridge/overpass sufficient for a fully-loaded school?	_____	_____
* Is the height of the tunnel/underpass adequate for the tallest school bus, including open roof hatches?	_____	_____
* Is the lane width of the bridge, tunnel/underpass, or overpass adequate for the widest school bus, including the mirrors?	_____	_____

Queuing /Storage Areas

Location _____	Yes	No
* Is there sufficient area for the largest school bus in the acceleration/deceleration lane?	_____	_____
* Is there sufficient area for the largest school bus in the median area between a multi-lane road?	_____	_____
* Is there sufficient area for the largest school bus in the turning lane?	_____	_____

Industrial Intersections and Construction Zones

Steep Downgrades

Location _____	Yes	No
* Do heavy vehicles enter/exit/cross the roadway frequently?	_____	_____

	Yes	No
* Are there highway signs alerting drivers of the industrial/construction traffic?	_____	_____
* Are there highway signs alerting drivers to the downgrade?	_____	_____
* Are there signs alerting drivers to "Check Brakes?"	_____	_____
* Are there areas marked and designated for vehicles to safely leave the road (run-off areas)?	_____	_____

Areas of Significant Speed Differential Between Vehicles

Location _____	Yes	No
* Is there sufficient space to accelerate/decelerate a school bus when entering/exiting a high-speed road?	_____	_____
* Does slow-moving farm equipment operate on the road?	_____	_____
* Do non-motorized vehicles, e.g., horse-drawn carriages, operate on the road?	_____	_____
* Are there roadway conditions, e.g., mountainous terrain, that result in vehicles operating at high speeds and low speeds?	_____	_____
What are they? _____		

Pedestrian Areas

Location _____	Yes	No
* Are there difficulties seeing pedestrians at school bus stops?	_____	_____
* Are there narrow streets with parked vehicles where children may run into the street?	_____	_____
* Are there areas of heavy pedestrian congestion, e.g., shopping and business areas?	_____	_____

Other Conditions Identified in Local Area

Location _____	Yes	No
* Are there unique roadway conditions?	_____	_____

	Yes	No
* Roads without guardrails that pose a danger, e.g., next to rivers, lakes, quarries?	_____	_____
* Dirt or gravel roads that could affect braking?	_____	_____
* Others?	_____	_____
What are they? _____		

* Are there roadway conditions that make it difficult to make a "right turn on red?"	_____	_____
What are they? _____		

* Are there areas with visibility problems due to industrial smoke, air quality, etc.?	_____	_____
* Are there areas where emergency equipment operate on a regular basis, e.g., fire stations or hospitals?	_____	_____

POLICIES AND PROCEDURES FOR PUPIL MANAGEMENT

The following should be adopted and implemented by school districts:

1. The bus driver's authority over, and responsibility for, pupils while in transit.
2. The pupil's right to due process when disciplinary action is taken.
3. A step-by-step procedure for resolving problems when the driver needs assistance.
4. The conditions under which a pupil might be temporarily or permanently suspended from the bus riding privilege.
5. Procedures for handling emergencies.
6. Use of bus monitors or bus attendants.
7. Requirements and responsibility for school bus passenger and pedestrian safety instruction.
8. Parent's or guardian's responsibility for damage caused by their children to the bus or its equipment.

EVALUATION CHECKLIST FOR SCHOOL BUS DRIVEWAYS IN THE VICINITY OF THE SCHOOL

NAME OF THE SCHOOL: _____ DATE: _____

LOCATION OF THE SCHOOL: _____

		YES	NO	DOES NOT APPLY
1.	School bus loading areas are provided on the school site.	<input type="checkbox"/>	<input type="checkbox"/>	<input type="checkbox"/>
2.	When loading and unloading of school pupils take place on main thoroughfare in front of the school, the roadway has a minimum width of 40 feet of hard surface.	<input type="checkbox"/>	<input type="checkbox"/>	<input type="checkbox"/>
3.	The driveway leading to and from the loading and unloading area for school buses has a minimum width of 30 feet of paved surface.	<input type="checkbox"/>	<input type="checkbox"/>	<input type="checkbox"/>
4.	If diagonal parking is provided for buses in the loading and unloading area, a minimum width of 60 feet of paved surface is available.	<input type="checkbox"/>	<input type="checkbox"/>	<input type="checkbox"/>
5.	Parking for loading and unloading of pupils at school is bumper-to-bumper or diagonal; in either case, the necessity for backing does not exist.	<input type="checkbox"/>	<input type="checkbox"/>	<input type="checkbox"/>
6.	The school bus is not required to back anywhere on school property.	<input type="checkbox"/>	<input type="checkbox"/>	<input type="checkbox"/>
7.	All school bus movement on the school grounds is one-way in a counter-clockwise direction.	<input type="checkbox"/>	<input type="checkbox"/>	<input type="checkbox"/>
8.	School bus traffic does not completely encircle the school building.	<input type="checkbox"/>	<input type="checkbox"/>	<input type="checkbox"/>
9.	The driver has proper sight distance at all points along the driveway.	<input type="checkbox"/>	<input type="checkbox"/>	<input type="checkbox"/>
10.	Crosswalks for pupils do not exist at the entrance to the school bus driveway.	<input type="checkbox"/>	<input type="checkbox"/>	<input type="checkbox"/>
11.	Separation is maintained between school bus traffic and all other traffic.	<input type="checkbox"/>	<input type="checkbox"/>	<input type="checkbox"/>
12.	Vehicular pickup points for non-bus pupils are on a separate driveway from that used by school buses.	<input type="checkbox"/>	<input type="checkbox"/>	<input type="checkbox"/>
13.	Curbing and suitable drainage are provided along driveways.	<input type="checkbox"/>	<input type="checkbox"/>	<input type="checkbox"/>

		YES	NO	DOES NOT APPLY
14.	Curbing and driveway construction comply with state highway specifications.	<input type="checkbox"/>	<input type="checkbox"/>	<input type="checkbox"/>
15.	At ingress and egress areas to and from the school, there is a minimum radius on inner edge of driveway pavement from 50 to 100 feet.	<input type="checkbox"/>	<input type="checkbox"/>	<input type="checkbox"/>
16.	On the school site, there is a minimum radius of inner edge of driveway pavement of 60 feet.	<input type="checkbox"/>	<input type="checkbox"/>	<input type="checkbox"/>
17.	Between reverse curves, at least a 50-foot tangent section is provided.	<input type="checkbox"/>	<input type="checkbox"/>	<input type="checkbox"/>
18.	At ingress and egress points a maximum grade of 2% is adhered to.	<input type="checkbox"/>	<input type="checkbox"/>	<input type="checkbox"/>
19.	A maximum grade of 5% is adhered to on the school bus driveway within the school site.	<input type="checkbox"/>	<input type="checkbox"/>	<input type="checkbox"/>

NOTE: A "yes" answer for each of the items indicates a well-planned traffic pattern for school buses.

SIGNATURES:

Person making the report: _____

Title: _____

Director of School Transportation: _____

NOTE: Most of the items included in this Evaluation Checklist are based on a 1966 Report of the Special Committee on School Plant Evaluation "School Planning: Safe Transporting," Bureau of Pupil Transportation, Department of Education, Trenton, New Jersey 08652.

PUPIL RULES
Supervision and Disciplinary Guidelines

1. Pupil shall follow directions of the driver the first time given.
2. Pupil shall arrive at the bus stop before the bus arrives.
3. Pupil shall wait in a safe place, clear of traffic and away from where the bus stops.
4. Pupil shall wait in an orderly line and avoid horseplay.
5. Pupil shall cross the road or street in front of the bus only after the bus has come to a complete stop and upon direction of the driver.
6. Pupil shall go directly to an available or assigned seat when entering the bus.
7. Pupil shall remain seated and keep aisles and exits clear.
8. Pupil shall exhibit classroom conduct at all times.
9. Pupil shall refrain from throwing or passing objects on, from or into buses.
10. Pupil is permitted to carry only objects that can be held on his/her lap.
11. Pupil shall refrain from the use of profane language, obscene gestures, tobacco, alcohol, drugs or any other controlled substance on the bus.
12. Pupil shall refrain from eating and drinking on the bus.
13. Pupil shall not carry hazardous materials, nuisance items and animals onto the bus.
14. Pupil shall respect the rights and safety of others.
15. Pupil shall refrain from leaving or boarding the bus at locations other than the assigned stops at home or school.
16. Pupil shall refrain from extending head, arms or objects out of the bus windows.
17. Pupil shall refrain from hitching rides via the rear bumper or other parts of the bus.

BUS CONDUCT REPORT

BUS NO. _____ SCHOOL: _____ DATE: _____

Pupils in the School District who ride buses are subject to rules and regulations designed to provide safe transportation to and from school. Any behavior which distracts the driver is a serious hazard to the safe operation of the vehicle, and as such, jeopardizes the safety of all passengers. Consequence of continued inappropriate behavior could result in your child being denied the bus riding privilege.

_____ has been cited for an infraction of the rule(s) checked below:
(name)

- | | |
|--|---|
| <input type="checkbox"/> Failure to remain seated | <input type="checkbox"/> Lighting matches |
| <input type="checkbox"/> Scuffling or fighting | <input type="checkbox"/> Throwing objects from window |
| <input type="checkbox"/> Profanity or obscene language | <input type="checkbox"/> Refusing to obey driver |
| <input type="checkbox"/> Smoking on the bus | <input type="checkbox"/> Bothering others |
| <input type="checkbox"/> Extending arm or head out window | <input type="checkbox"/> Throwing objects on bus |
| <input type="checkbox"/> Possession of harmful or illegal items. | <input type="checkbox"/> Other (See Comment) |

COMMENT: _____

DRIVER'S SIGNATURE: _____ DATE: _____

PRINT NAME: _____

DATE OF OFFENSE: _____ FIRST OFFENSE: _____

SECOND OFFENSE: _____ THIRD OFFENSE: _____

SCHOOL ADMINISTRATOR'S ACTION: _____

SCHOOLADMINISTRATOR'S
SIGNATURE: _____

DATE: _____

PRINT

NAME: _____

PARENT/GUARDIAN'S
COMMENT: _____

PLEASE SIGN AND RETURN TO SCHOOLADMINISTRATOR

Parent/Guardian's Signature: _____ Date: _____

Print

Name: _____

White-School Administrator's Copy
Pink-Parent/Guardian's Copy

Canary-Bus Driver's Copy
Gold-Pupil's Copy

First offenses require at least a notification to the pupil and parent or guardian either by phone or in person by appropriate school personnel. Second and subsequent offenses may require a conference with the pupil, parent or guardian, driver and school administrator(s) which may result in a period of suspension of pupil's riding privileges.

A form such as the one above should be used for reporting purposes.

WHEN LEAVING YOUR BUS:

Here's How to Cross the Road SAFELY

WALK—along the side of the road until you can see your driver

STOP—wait for the signal to cross

WALK & LOOK—for traffic both ways

—if you see a vehicle that has not stopped, go back to the bus immediately

—if all vehicles have stopped, cross the road quickly

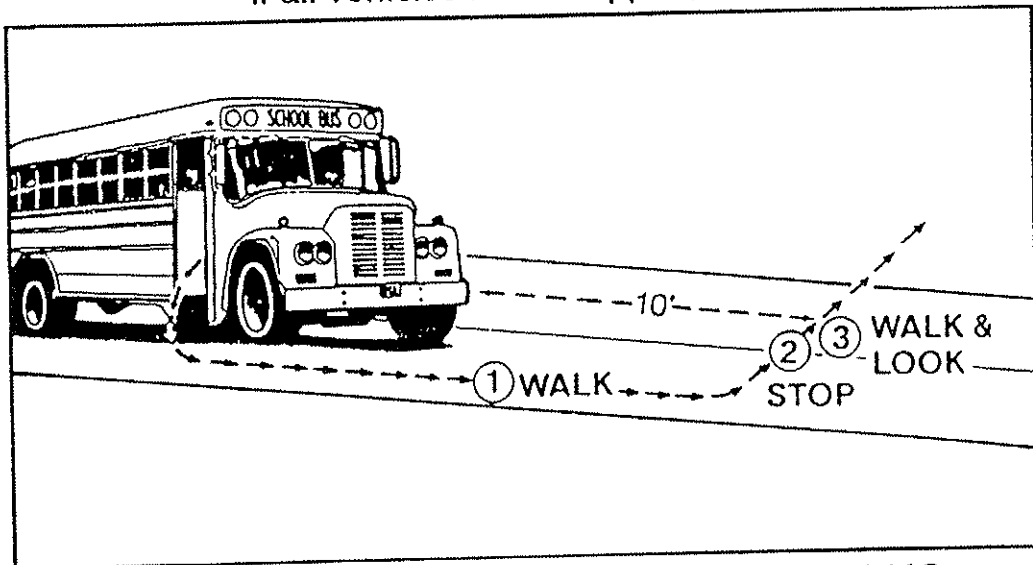

Crossing the Highway is **DANGEROUS**

REMEMBER {
• WALK
• STOP
• WALK & LOOK

**Drivers SHOULD stop...But
THEY MAY NOT!**

WHEN BOARDING YOUR BUS:
**Here's How to Cross the Road
SAFELY**

FOLLOW THE 10 FOOT RULE:

- STAY—on your side of the road—far away from the traffic
- WAIT—for the bus to stop and for your driver's signal to cross
- CHECK—traffic both ways—then check again
- CROSS—walk directly across, checking traffic both ways
- WALK—approximately 10 feet ahead of the bumper and board bus quickly

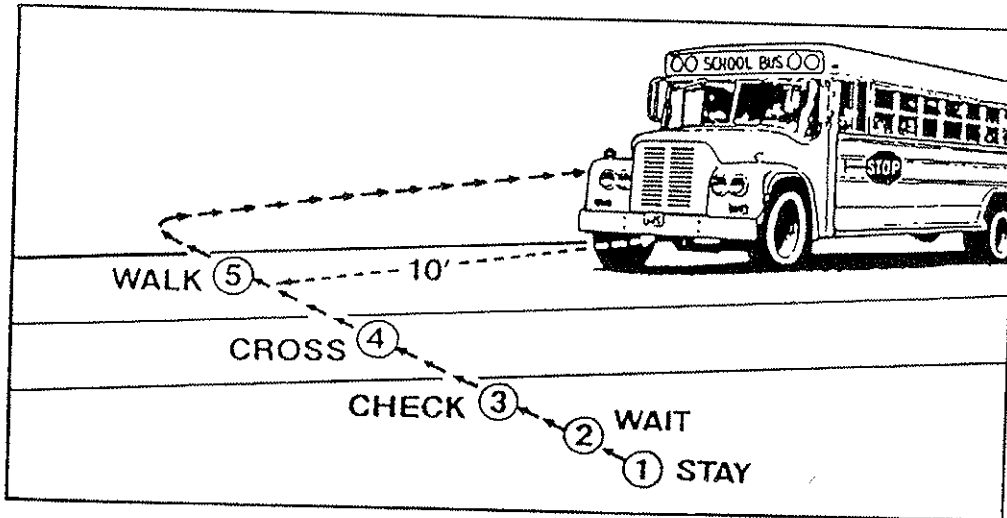

REMEMBER

- Stay on your side of the road until your driver signals you to cross
- Check and recheck for traffic
- Follow the 10 foot rule
- Board bus quickly—go directly to your seat

**Drivers SHOULD stop...But
THEY MAY NOT!**

RECOMMENDED PROCEDURES FOR SCHOOL BUS DRIVERS AT RAILROAD GRADE CROSSINGS

Each year, approximately 4,000 train/vehicle collisions occur at railroad crossings. These 4,000 collisions result in about 500 fatalities and 1,500 injuries. Unfortunately, some of the crashes involve school buses that result in injuries and fatalities to students. In an effort to avert these crashes, the following procedures are recommended to school bus drivers. It is important to note that these recommendations must be considered within the context of individual state laws and regulations.

1. When making stops for railroad crossings, carefully observe all traffic. Use the school bus's hazard warning lamps, and tap the brakes to communicate to traffic that the bus is about to stop. Take these actions far enough in advance to avoid startling motorists behind the bus, which could cause panic stops or rear-end collisions.
2. Bring the bus to a full and complete stop before crossing any track, whether or not the bus is carrying passengers. Stop the bus within not less than 15 feet or more than 50 feet from the rails nearest the front of the bus.
3. On multiple-lane roads, stop only in the right lane unless it is necessary to make a left turn immediately after crossing the railroad tracks.
4. After stopping the bus, fully open the service door and the driver's side window, turn off all noisy equipment (radios, fans, etc.), instruct students to be quiet, and look and listen in both directions along the track or tracks for approaching trains. In instances where the school bus loading/unloading red warning lamps are activated by opening the service door, deactivate such lamps by using the master control switch.
5. If the view of the railroad track or tracks is not adequate, do not attempt to cross the tracks until you can see that no train is approaching.
6. If a train passes from one direction, make sure that another train, possibly hidden by the first train, is not approaching on an adjacent track.
7. For railroad crossings equipped with warning devices such as lights, bells, and/or gates, always obey the signals. Never ignore railroad crossing signals. If a police officer or flagman is present at the crossing, obey their directions, but be sure to make your own visual check.
8. Before crossing the tracks, ensure there is adequate room on the other side of the tracks and train right-of-way for the entire bus. It is always possible that the bus may have to stop immediately after crossing the railroad tracks.
9. When the tracks are clear, completely close the bus service entry door and place the transmission in a gear that will not require changing gears while crossing the tracks. In instances where the school bus loading/unloading red warning lamps are activated by opening the service door, and such lamps were deactivated by using the master control switch, reactivate the school bus loading/unloading lamps. Leave all noisy equipment turned off, and continue looking in all directions as the bus crosses the tracks. After safely crossing the tracks, turn off the hazard warning lamp.

10. If the bus stalls while crossing the tracks, evacuate the students and move them a safe distance away from the bus as quickly as possible. If a radio or telephone is available, notify the school dispatcher of the situation. If a train is approaching, have everyone walk in the direction of the train at a 45 degree angle away from the train tracks.
11. Weather conditions, such as fog, snow, rain, and wind, can affect the driver's ability to see and hear an approaching train and to determine the safety of crossing railroad tracks. Additional caution must be exercised during such conditions.
12. Report malfunctioning railroad signals or hazardous railroad crossing conditions to the appropriate school transportation personnel.

Additional information and training materials on railroad crossing safety are available from:

Operation Lifesaver, Inc.
1420 King Street
Alexandria, VA 22314
1-800-537-6224

Although the information and recommendations contained in this publication have been compiled from sources believed to be reliable, other or additional safety measures may be required under particular circumstances.

(Adapted from Fact Sheet, "Recommended Procedures for School Bus Drivers at Railroad Crossings," revised, School Transportation Section, 1998, National Safety Council, 1121 Spring Lake Drive, Itasca, IL 60143-3201, (630) 285-1121.)

TRIP REQUEST FORM

Trip Date: _____ School: _____

Trip Destination: _____

Depart From: _____ No. Passengers: _____

Extra Equipment: _____

Departure Time: _____ Arrival Time: _____

Meal Stop Required yes no If yes, where? _____

Purpose of Trip: _____

Transportation Requested By: _____ Date: _____

Approved By: _____ Date: _____

Reimbursement Category: _____

TRANSPORTATION USE:

Vehicle Assigned: _____ Driver: _____

Spot Time: _____ Spot Location: _____

Routing Information: _____

Dispatcher Signature: _____ Date: _____

Time Out: _____ Time In: _____ Total Time: _____

Mileage Out: _____ Mileage In: _____ Total Miles: _____

Actual No. Passengers: _____

Remarks: _____

Driver's Signature: _____ Date: _____

INSTRUCTIONS FOR CONDUCTING EMERGENCY EXIT DRILLS

There is an urgent need, due to the increased number of pupils being transported and the increased number of accidents on the highways, to instruct pupils on how to properly vacate a school bus in case of an emergency. It is possible for pupils to block the emergency door if all are trying to get out at the same time. Also, there is a possibility of danger when pupils jump from the rear emergency door exit. To avoid these situations, schools should organize and conduct emergency exit drills for all pupils who ride the school bus, even occasionally.

Reasons for actual emergency evacuations:

1. Fire or danger of fire. Being near an existing fire and unable to move the bus, or being near the presence of gasoline or other combustible material is considered dangerous and pupils should be evacuated. The bus should be stopped and evacuated immediately if the engine or any portion of the bus is on fire. Pupils should be moved to a safe place 100 feet or more from the bus and instructed to remain there until the driver has determined that the danger has passed.
2. Unsafe position. When the bus is stopped because of an accident, mechanical failure, road conditions, or human failure, the driver must determine immediately whether it is safer for pupils to remain on or evacuate the bus.
3. Mandatory evacuations. The driver must evacuate the bus when the following situations arise:
 - a. Fire or threat of fire is apparent.
 - b. The final stopping point is in the path of a train or adjacent to railroad tracks.
 - c. The stopped position of the bus may change and increase the danger (e.g., a bus comes to rest near a body of water or at a precipice where it could still move and go into the water or over a cliff). The driver should be certain that the evacuation is carried out in a manner which affords maximum safety for the pupils.
 - d. The stopped position of the bus is such that there is danger of collision.
4. Sight distance. In normal traffic conditions, the bus should be visible for a distance of 300 feet or more. A position over a hill or around a curve where such visibility does not exist should be considered reason for evacuation.
5. Important factors pertaining to school bus evacuation drills:
 - a. Safety of pupils is of the utmost importance and must be first considered.
 - b. All drills should be supervised by the principal or by persons assigned to act in a supervisory capacity.
 - c. The bus driver is responsible for the safety of the pupils. When the driver is incapacitated and unable to direct the evacuation, school patrol members, appointed pupils or adult monitors should be authorized to direct these drills. It is important to have regular substitutes available.
6. Pupils appointed to direct evacuation drills should possess the following qualifications:
 - a. Maturity.

- b. Good citizenship.
 - c. Live near end of bus route.
7. Appointed pupils should know how to:
- a. Turn off ignition switch/shut down engine.
 - b. Set emergency brake.
 - c. Summon help when and where needed.
 - d. Use kick out windows or emergency escape exits.
 - e. Set warning devices.
 - f. Open and close doors and account for all pupils passing the station.
 - g. Help small pupils off bus.
 - h. Perform other assignments.
 - i. Use of electronic voice equipment to summon help.
 - (1) School bus driver and attendants should be active participant.
 - (2) Drills should be scheduled in a manner similar to fire drills held regularly in schools. They should be held more often during fall and spring months and conducted when the bus arrives at the school building with the pupils.
 - (3) Drills should be restricted to school property and conducted under the supervision of school officials.
 - (4) Types of drills should be varied.
8. Driver should stay in bus during evacuation drill. He/she must set the parking brake, turn the engine off and place the manual transmission in gear.
9. Pupils should not be permitted to take lunch boxes, books, etc., with them when they leave the bus. The objectives are to get pupils off safely in the shortest time possible and in an orderly fashion.
10. Pupils should travel a distance of at least 100 feet from the bus in an emergency drill and remain there until given further directions.
11. All pupils should participate in the drill, including those who ride only on special trips.
12. Each pupil should be instructed in proper safety precautions.
13. Pupils should be instructed in how and where to obtain assistance in emergencies. Written instructions and telephone numbers should be posted in the bus.

14. There are several different drills:
- a. Everyone exits through the front entrance doors and emergency door configurations.
 - b. Everyone exits through the rear-most emergency door(s).
 - c. Front half exits through the front door and rear half exits through the rear-most door.
 - d. All rear engine buses are equipped with a left side emergency door in lieu of a rear emergency door (See Diagram). This exit should also be utilized for evacuation drills.
 - e. Some states also require side emergency doors in addition to rear emergency doors.
 - f. Students should be familiar with the operation of emergency windows, both side and rear, and roof hatches. All exits should be opened by students during evacuation drills to ensure their ability to operate such devices.
 - g. Every school bus driver shall ensure the students assigned to their bus are familiar with the emergency exit configuration of their assigned bus.
 - h. Identification of seat rows and positions similar to airline seating is recommended (i.e., left front seat 1, a, b, c, right front seat 1, d, e, f, etc.)

EVACUATION PROCEDURES
for
ACTIVITY TRIPS AND FIELD TRIPS

In order to ensure the safety of school bus passengers in an actual emergency, every school bus driver assigned to transport students on activity trips or field trips, shall assign an evacuation team prior to each trip. The team may consist of teachers, coaches, students or any other passenger. A roster should be provided to the driver accounting for all passengers.

Passengers assigned to evacuation teams must be seated where they can effectively carry out their responsibilities in an emergency.

Each Evacuation Team will consist of at least the following:

1. A passenger assigned to set the parking brake, turn off the engine, turn on warning flashers and to call in on the radio or other means, and report the incident to the Transportation Department, in case the driver is unable to do so.
2. A passenger assigned to lead passengers to a safe location at least 100 feet from the bus and to take the first aid kit off the bus.
3. Two passengers assigned to stand outside the bus, next to the front door, to help students exit the bus and for taking the fire extinguisher.
4. Two passengers assigned to stand outside the bus next to the rear door, to help students exit the bus.

In addition to assigning an evacuation team, the following information shall be discussed and/or demonstrated prior to each activity trip or field trip:

1. Location and use of the fire extinguisher.
2. Location of the first aid kit.
3. Location of the warning reflectors.
4. Location and use of all emergency exits.
5. How to shut off the engine and set the parking brake.
6. How to open the service door, to include, safety releases on manual, air or vacuum doors, if so equipped.
7. Instruct passengers to keep aisles clear at all times and not to block emergency exists.

THE DRIVER OF THIS TRIP DID ASSIGN AN EVACUATION TEAM AND EXPLAINED THE EMERGENCY PROCEDURES TO OUR GROUP.

Sponsor _____ Date _____

APPENDIX F
Special Needs
Transportation

APPENDIX F

SPECIAL EDUCATION DEPARTMENT FORMS

Form 1

CONSENT FOR DISCLOSURE OF MEDICAL INFORMATION AND RECORDS

TO: _____
(Physician's Name and Address)

I, _____, the (parent/guardian) of _____ (Pupil) consent and authorize you to disclose and provide to the _____ (School District), its nursing and other necessary service providers, upon the school district's request, any information or records which you have or have obtained concerning the diagnosis, evaluations, tests, medical problems or conditions, medications, or treatments of my child or ward named above.

It is the expressed intent of this document to waive any and all privileges which I or my child or ward might have with respect to disclosure of the above information and records to the school district, including the doctor-patient privilege, psychologist-client privilege, and social worker-client privilege.

Signature of Parent or Guardian: _____

Print Name: _____

Dated: _____

PLEASE RETURN TO:

Form 2

REQUEST FOR MEDICAL VERIFICATION OF HEALTH STATUS AND NEEDS

SCHOOL DISTRICT: _____
(Address)

NAME: _____ BIRTH DATE: _____

ADDRESS: _____ PHONE: _____

PARENT/GUARDIAN NAME: _____ PHONE: _____

ADDRESS (IF DIFFERENT): _____

PHYSICIAN: _____

NOTE TO PHYSICIAN: Should you have any questions regarding this request, please contact: _____

PHONE: _____

A. VERIFICATION OF MEDICAL, HEALTH AND BEHAVIOR STATUS.

1. Briefly describe the current medical, health and behavioral status.
2. Identify any medical conditions not addressed in A above.
3. Identify any health concerns that are not addressed in A above.
4. Identify any behavioral concerns that are not addressed above.

B. PARTICIPATION IN THE SCHOOL DAY PROGRAM

1. Briefly describe the staff supervision and interventions necessary for the pupil to safely participate in the normal school day program, given the pupil's health and medical status.
2. Identify the training required for all staff, including bus attendants and drivers, to provide the supervision and interventions addressed in A above.
3. Identify any additional restrictions or modifications in school activities or medical care that would be necessary for the pupil to safely participate in the school day program.
4. Identify any additional special equipment, aids, restraints, or mobility assistance needed for the pupil to safely participate in the school day program.

Form 3

MEDICAL PROCEDURE AUTHORIZATION

I delegate and authorize the staff of the _____ School District to perform for (pupil) the acts, tasks, and functions indicated on the Request for Medical Verification of Health Status and Needs, dated _____, which I previously provided to the district. This authorization is subject to the condition that district staff assigned to perform these activities have been provided the required training as specified in the above request.

I have reviewed the attached procedures for _____ (procedure) that will be utilized and approve them, subject to any specific modifications necessary for this student, which I have noted on the procedures.

I agree to supervise the performance of these activities and procedures by being continuously available through direct communications with district staff performing them and by regularly reviewing the student's health/medical status and needs, as well as the procedures being utilized by the staff.

Signature of Physician

Date

Form 4

PUPIL TRANSPORTATION CARD-STUDENTS WITH DISABILITIES

Pupil's Name: _____ Date: _____

Address: _____ Home Phone: _____

Father's Work Phone: _____ Mother's Work Phone: _____

Emergency Phone: _____

Please check appropriate type of transportation for your child:

- | | |
|--|--|
| <input type="checkbox"/> Walks to bus unassisted | <input type="checkbox"/> Walks to bus, but needs assist. |
| <input type="checkbox"/> Requires a car seat | <input type="checkbox"/> Wheelchair |
| <input type="checkbox"/> Needs to be carried | <input type="checkbox"/> Requires Special Restraint |
| <input type="checkbox"/> Booster seat | <input type="checkbox"/> Positioning Devices |
| <input type="checkbox"/> Special Equipment | <input type="checkbox"/> Requires Attendant |
| <input type="checkbox"/> Needs to be met at school? | <input type="checkbox"/> Other (Specify) _____ |
| <input type="checkbox"/> On return/home, needs to be met at Bus Stop | |

Names & Addresses of persons near pupil's residence who have consented to care for the pupil if the parents are not available:

Name: _____ Address: _____ Phone: _____

Name: _____ Address: _____ Phone: _____

Name: _____ Address: _____ Phone: _____

Please check if any of the following applies to your child:

- | | |
|--------------------------------------|---|
| <input type="checkbox"/> Asthma | <input type="checkbox"/> Heart Disease |
| <input type="checkbox"/> Diabetes | <input type="checkbox"/> Blind |
| <input type="checkbox"/> Deaf | <input type="checkbox"/> Chronic Respiratory Problems |
| <input type="checkbox"/> Non-Verbal | <input type="checkbox"/> Bee Sting Reaction |
| <input type="checkbox"/> Hemophiliac | <input type="checkbox"/> Allergies—to what? _____ |

Seizures:

How long does seizure last? _____

How often does it occur? _____

Action needed, if any: _____

Is your child on medication? Yes No

If yes, what medication, what dosage, and when given? _____

Family Doctor: _____ Address: _____

Doctor's Phone Number: _____ Family Designated Hospital: _____

Parental Contact: If possible and practical, in the event of major emergency, parent contact will be made.

Parental Approval: If, in the opinion of the driver, a major emergency exists, the parent(s) have agreed in writing and will assume the cost of:

- | | | | | |
|--|--------------------------|-----|--------------------------|----|
| 1. Contacting the family doctor | <input type="checkbox"/> | Yes | <input type="checkbox"/> | No |
| 2. Contacting any doctor available | <input type="checkbox"/> | Yes | <input type="checkbox"/> | No |
| 3. Contacting rescue squad | <input type="checkbox"/> | Yes | <input type="checkbox"/> | No |
| 4. Transporting to designated hospital | <input type="checkbox"/> | Yes | <input type="checkbox"/> | No |

Other Helpful Information: _____

As parent or guardian, I agree to one or more of the above procedures as indicated and agree that this information may be shared with my child's transporter.

CONFIDENTIALITY WILL BE MAINTAINED.

Parent or Guardian's Signature

Date:

DO NOT WRITE BELOW THIS LINE

Bus Company: _____

Bus No. _____ Telephone: _____

Special Instructions for Driver: _____

Form 5

**TRANSPORTATION SERVICE REQUIREMENTS FOR
PASSENGERS WITH HEALTH CONCERNS**

SCHOOL DISTRICT: _____

ADDRESS: _____

DATE: _____ ASSIGNED SCHOOL: _____

GRADE LEVEL: _____ SPECIFIC PROGRAM: _____

HOME SCHOOL: _____ NAME OF STUDENT: _____

BIRTH DATE: _____ STUDENT I.D. #: _____

HOME ADDRESS: _____ ZIP: _____

HOME PHONE: _____

A.M. PICK-UP LOCATION: _____ PHONE: _____

P.M. DROP-OFF LOCATION: _____ PHONE: _____

PARENT(S)
NAME: _____

FATHER'S WORK PHONE: _____ MOTHER'S WORK PHONE: _____

EMERGENCY/ALTERNATE CONTACT:

Name: _____ Phone: _____

Address: _____

Name: _____ Phone: _____

Address: _____

EMERGENCY MEDICAL INFORMATION:

Student's

Doctor: _____ Phone: _____

Hospital

Preference: _____ Address: _____

ALLERGIES: _____

MEDICATION STUDENT IS UNDER: _____

DOSAGE: _____

SPECIAL INSTRUCTIONS FOR ATTENDING PHYSICIAN(S): _____

SPECIFIC INSTRUCTIONS IF PARENT(S) ARE NOT AT HOME: _____

LEVEL OF SUPERVISION REQUIRED (Attach Medical Procedure Authorization and Procedures): _____

REQUIRED TRAINING FOR SUPERVISION: _____

INTERVENTIONS REQUIRED (Attach Medical Procedure Authorization and Procedures): _____

REQUIRED TRAINING FOR INTERVENTIONS: _____

OTHER ADDITIONAL RESTRICTIONS OR MODIFICATIONS NECESSARY TO TRANSPORT STUDENT:

DISABILITY CONDITIONS AFFECTING TRANSPORTATION: _____

SPECIAL EQUIPMENT, AIDS OR MOBILITY ASSISTANCE REQUIRED: _____

ADDITIONAL COMMENTS/INSTRUCTIONS: _____

PROCEDURE IF CHANGE IN SERVICE IS NECESSARY: If there are any changes in the pupil's health, medical or behavior status which the parent(s), physician, transportation, or other school staff believe may merit changes in staffing, precautions to be taken, interventions, restraints, or any other procedure noted above, the concerned party shall immediately contact: _____
(phone: _____) who will in turn initiate the process to evaluate and recommend necessary changes with the involvement of parents(s), physician, school and transportation staff.

APPROVAL OF TRANSPORTATION SERVICE REQUIREMENTS

Each of the following persons has participated in the development of these transportation service requirements and by signing below approves them for implementation.

Dated: _____ Signature of Parent / Guardian _____

Print Name: _____

Dated: _____ Signature of School District Representative _____

Title: _____

Dated: _____ Signature of Transportation Staff Representative _____

Title: _____

Dated: _____ *Signature of Private Contracted Transporter _____

Title: _____

Dated: _____ *Signature of School Nurse _____

Dated: _____ *Signature of Physician _____

*If an appropriate signature under the circumstances.

cc: All transportation service providers.

PROCEDURE FOR LIFTING PASSENGERS

PURPOSE: The purpose of proper lifting techniques is to move the passenger without injury to yourself or the passenger.

BASIC RULES

1. Tell the passenger what you are going to do.
2. Estimate the weight of the passenger. NEVER ATTEMPT TO CARRY ALONE A PUPIL WHO WEIGHS MORE THAN HALF YOUR OWN WEIGHT unless the safety of the pupil is in immediate danger and no assistance is available.
3. Always attempt to get help if you have any doubts about your ability to lift the student. If there is only a driver on a bus, and the necessity for an emergency evacuation develops, some districts suggest that the driver activate the alternating red lights, as the evacuation procedure is truly an UNLOADING PROCEDURE. Such action can draw attention from motorists that you need assistance. District policy should determine if this procedure is appropriate.
4. Be sure your path is CLEAR.
5. Stand with both feet firmly planted about shoulder-width apart for good balance.
6. Always bend from knees, not from back, so that you use your thigh muscles and buttock muscles rather than you back muscles to do the lifting.
7. When lifting and carrying, keep the pupil as close to your own body as possible.
8. Shift the position of your feet to move. DO NOT TWIST YOUR BODY. Take small steps to turn.

SINGLE-PERSON LIFT

1. Follow the basic rules 1-8. Most strains, fatigue, and back injuries caused by lifting are due to using the WRONG muscles. Use your STRONG LEG AND BUTTOCK MUSCLES (by bending at the knees and hips), NOT YOUR BACK MUSCLES. Maintain the normal curves of the spine when lifting and avoid rounding of the upper back. (Keep your back straight!)
2. Keep equal weight on both feet and lower yourself to the level of the pupil by bending your knees and hips before lifting.
3. Once in position, put one arm around the pupil's upper back and the other under both knees.

TWO-PERSON LIFT

1. Follow Basic Rules 1-8.
2. TO LIFT FROM A WHEELCHAIR:
 - A. Position the wheel chair as close to your destination as possible. In an emergency situation, to save time and congestion, leave the chair where it is strapped and blanket-pull or carry the student to the appropriate exit location.

- B. One person stands in front to the side, the other in back.
 - C. The person in front removes the arm rest (if detachable) and folds up the footrest.
 - D. The person in back removes the seat belt and any other positioning device.
 - E. The person in front, bending from knees and hips, lowers himself or herself to place one arm under the pupil's knees and the other under the occupants' thighs.
 - F. Person in back, places his or her arms under pupil's armpits, reaching forward to grasp both pupil's wrists firmly. (Your right hand to pupils' right wrist; left hand to left wrist.)
 - G. Lift together on the count of 3. (REMEMBER TO USE YOUR LEGS AND BUTTOCK MUSCLES TO LIFT.)
 - H. Walk to area where pupil is to be placed and lowered on the count of 3, bending from the knees and hips.
3. TO LIFT FROM A BUS SEAT:
- A. Use the same procedure as above, but first, SLIDE THE PUPIL TO THE EDGE OF THE BUS SEAT NEAR THE AISLE.

BLANKET LIFT

- 1. Fold a blanket in half, place on the floor as close to the pupil as possible.
- 2. Follow lifting rules 1-8 and lower the pupil to the blanket.
- 3. ONE PERSON LIFT: Place the pupil's head toward the direction of exit, lift the blanket from the head and slide to safety.

TO ASSIST A PERSON UP STAIRS

- 1. Follow basic rules 1-8.
- 2. Curl the pupil up as much as possible. Keep the pupil's arms and legs from flopping loosely. This flopping could throw you off balance, and cause a fall.
- 3. Support the pupil's head and neck as you would an infant's.
- 4. Do not lift pupils up by an arm or leg except in an extreme emergency.
- 5. Slow rocking or a firm holding will help to relax a very tense pupil.

BASIC BODY MECHANICS

- 1. Size up load and do not hesitate to ASK for help.

2. Be sure that the student or pupil knows you are going to lift him/her.
3. Plan ahead how you will lift and where you are going.
4. Bend your knees and hips instead of your back. Keep your back straight. Maintain the normal curves of the spine as lifting.
5. Keep your feet apart while lifting to give a broad base of support.
6. Keep the student or person CLOSE to you.
7. If lifting with someone else, lift smoothly and together. Count 1,2,3.
8. Take small steps. Never twist your body while lifting or carrying.

Characteristics of Disabilities as Defined by IDEA

Definitions of disability terms. The terms used in this definition are defined as follows:

- (1) *Autism* means:
 - (i) a developmental disability significantly affecting verbal and nonverbal communication and social interaction, generally evident before age 3, that adversely affects a child's educational performance. Other characteristics often associated with autism are engagement in repetitive activities and stereotyped movements, resistance to environmental change or change in daily routines, and unusual responses to sensory experiences. The term does not apply if a child's educational performance is adversely affected primarily because the child has an emotional disturbance, as defined in paragraph (b)(4) of this section.
 - (ii) A child who manifests the characteristics of autism after age 3 could be diagnosed as having autism if the criteria in paragraph (c)(1)(i) of this section are satisfied.
- (2) *Deaf-blindness* means concomitant hearing and visual impairments, the combination of which causes such severe communication and other developmental and educational needs that they cannot be accommodated in special education programs solely for children with deafness or children with blindness.
- (3) *Deafness* means a hearing impairment that is so severe that the child is impaired in processing linguistic information through hearing, with or without amplification, that adversely affects a child's educational performance.
- (4) *Emotional disturbance* is defined as follows:
 - (i) The term means a condition exhibiting one or more of the following characteristics over a long period of time and to a marked degree that adversely affects a child's educational performance:
 - (A) An inability to learn that cannot be explained by intellectual, sensory or health factors.
 - (B) An inability to build or maintain satisfactory interpersonal relationships with peers and teachers.
 - (C) Inappropriate types of behavior or feelings under normal circumstances.
 - (D) A general pervasive mood of unhappiness or depression.
 - (E) A tendency to develop physical symptoms or fears associated with personal or school problems.
 - (ii) The term includes schizophrenia. The term does not apply to children who are socially maladjusted, unless it is determined that they have an emotional disturbance.
- (5) *Hearing impairment* means an impairment in hearing, whether permanent or fluctuating, that adversely affects a child's educational performance but that is not included under the definition of deafness in this section.
- (6) *Mental retardation* means significantly sub-average general intellectual functioning, existing concurrently with deficits in adaptive behavior and manifested during the developmental period, that adversely affects a child's educational performance.

- (7) *Multiple disabilities* means concomitant impairments (such as mental retardation-blindness, mental retardation-orthopedic impairment, etc.), the combination of which causes such severe educational needs that they cannot be accommodated in special education programs solely for one of the impairments. The term does not include deaf-blindness.
- (8) *Orthopedic impairment* means a severe orthopedic impairment that adversely affects a child's educational performance. The term includes impairments caused by congenital anomaly (e.g., clubfoot, absence of some member, etc.), impairments caused by disease (e.g., poliomyelitis, bone tuberculosis, etc.), and impairments from other causes (e.g., cerebral palsy, amputations, and fractures or burns that cause contractures).
- (9) *Other health impairment* means having limited strength, vitality or alertness, including a heightened alertness to environmental stimuli, that results in limited alertness with respect to the educational environment, that—
- (i) Is due to chronic or acute health problems such as asthma, attention deficit disorder or attention deficit hyperactivity disorder, diabetes, epilepsy, a heart condition, hemophilia, lead poisoning, leukemia, nephritis, rheumatic fever, and sickle cell anemia; and
 - (ii) Adversely affects a child's educational performance.
- (10) *Specific learning disability* is defined as follows:
- (i) General. The term means a disorder in one or more of the basic psychological processes involved in understanding or in using language, spoken or written, that may manifest itself in an imperfect ability to listen, think, speak, read, write, spell, or to do mathematical calculations, including conditions such as perceptual disabilities, brain injury, minimal brain dysfunction, dyslexia and developmental aphasia.
 - (ii) Disorders not included. The term does not include learning problems that are primarily the result of visual, hearing, or motor disabilities, of mental retardation, of emotional disturbance or of environmental, cultural or economic disadvantage.
- (11) *Speech or language impairment* means a communication disorder, such as stuttering, impaired articulation, a language impairment, or a voice impairment, that adversely affects a child's educational performance.
- (12) *Traumatic brain injury* means an acquired injury to the brain caused by an external physical force, resulting in total or partial functional disability or psychosocial impairment, or both, that adversely affects a child's educational performance. The term applies to open or closed head injuries resulting in impairments in one or more areas, such as cognition; language; memory; attention; reasoning; abstract thinking; judgment; problem-solving; sensory, perceptual, and motor abilities; psychosocial behavior; physical functions; information processing; and speech. The term does not apply to brain injuries that are congenital or degenerative, or to brain injuries induced by birth trauma.
- (13) *Visual impairment, including blindness*, means an impairment in vision that, even with correction, adversely affects a child's educational performance. The term includes both partial sight and blindness.

**SAMPLE CONTINUUM
OF TRANSPORTATION SERVICES FOR STUDENTS WITH DISABILITIES
(CHOICE OF OPTION THAT MAY BE AVAILABLE AS APPROPRIATE)**

Least Restrictive	Most Restrictive										
<p>student walks to school alone or with peers</p>	<p>public transit use varies</p>	<p>student uses public transit one way</p>	<p>student uses public transit both ways</p>	<p>student rides school bus possibly with modification or lift</p>	<p>student rides school bus w/ support network w/ adaptive equipment</p>	<p>student rides modified bus w/ attendant w/ adaptive equipment</p>	<p>student rides modified bus w/ attendant and/or nurse w/ special training possibly w/ limited ride time possibly w/ specially equipped vehicle possibly w/ intervention</p>	<p>student needs specialized bus ride w/ specialized attendant</p>	<p>student needs specialized pick up or bus ride ALONE w/ attendant</p>	<p>student needs bus alternative for out of town travel</p>	<p>transportation inappropriate for student (may be eligible for home/hospital teacher)</p>
<p>USE CORNER BUS STOPS OR SCHOOL PICK UP SITES</p>	<p>Parent/guardian to provide their own child's transportation with district reimbursement</p>							<p>HOME OR INSTITUTION PICK UP</p>			

IDEA-PART B FINAL REGULATIONS*
DISCIPLINE PROCEDURES
(March 1999)

Introduction

Prior to enactment of the IDEA Amendments of 1997, the statute only specifically addressed the issue of discipline in a provision that allowed school personnel to remove a child to an interim alternative educational placement for up to 45 days if the child brought a gun to school or to a school function. The 1997 Amendments incorporated prior court decisions and Department policy that had held that:

1. Schools could remove a child for up to ten school days at a time for any violation of school rules as long as there was not a pattern of removals;
2. A child with a disability could not be long-term suspended or expelled from school for behavior that was a manifestation of his or her disability; and
3. Services must continue for children with disabilities who are suspended or expelled from school.

In addition, the 1997 Amendments:

1. Expanded the authority of school personnel regarding the removal of a child who brings a gun to school to also apply to all dangerous weapons and to the knowing possession of illegal drugs or the sale or solicitation of the sale of controlled substances; and
2. Added a new ability of schools to request a hearing officer to remove a child for up to 45 days if keeping the child in his or her current placement is substantially likely to result in injury to the child or to others.

The Amendments also added new provisions that require schools to assess a child's troubling behavior and develop positive behavioral interventions to address that behavior, and that describe how to determine whether the behavior was a manifestation of the child's disability.

The final regulations incorporate the statutory provisions described above, and provide additional specificity on a number of key issues:

Removals of Up to Ten School Days at a Time

The regulations clarify that school personnel may remove a child with a disability for up to ten (10) school days, and for additional removals of up to ten school days for separate acts of misconduct, as long as the removals do not constitute a pattern.

Providing Services During Periods of Disciplinary Removal

Schools do not need to provide services during the first ten school days in a school year that a child is removed.

During any subsequent removal that is for ten school days or less, schools provide services to the extent determined necessary to enable the child to appropriately progress in the general curriculum and appropriately advance toward achieving the goals of his or her IEP. In cases involving removals for ten school days or less, school personnel, in consultation with the child's special education teacher, make the service determination.

During any long-term removal for behavior that is not a manifestation of a child's disability, schools provide services to the extent determine necessary to enable the child to appropriately progress in the general curriculum and appropriately advance toward achieving the goals of his or her IEP. In cases involving removals for behavior that is not a manifestation of the child's disability, the child's IEP team makes the service determination.

Conducting Behavioral Assessments and Developing Behavioral Interventions

Meetings of a child's IEP team to develop a behavioral assessment plan, or (if the child has one) to review the child's behavioral intervention plan, are required only when the child has first been removed from his or her current placement for more than ten school days in a school year, and when commencing a removal that constitutes a change in placement.

If other subsequent removals occur, the IEP team members review the child's behavioral intervention plan and its implementation to determine if modifications are necessary, and only meet if one or more team members believe that modifications are necessary.

Change of Placement; Manifestation Determinations

The regulations provide that a change of placement occurs if a child is removed for more than ten consecutive school days or is subjected to a series of removals that constitute a pattern because they cumulate to more than ten school days in a school year, and because of factors such as the length of each removal, the total amount of time the child is removed, and the proximity of the removals to one another.

Manifestation determinations are required only if a school is implementing a removal that constitutes a change in placement.

Form 6 Transportation Checklist

Student Name: _____ ID: _____

School: _____ Grade: _____ Date: _____

- | | Yes | No | |
|----|--------------------------|--------------------------|---|
| | | | Special Education Services |
| 1. | <input type="checkbox"/> | <input type="checkbox"/> | Will services be provided at the school of residence? |
| 2. | <input type="checkbox"/> | <input type="checkbox"/> | Is the student eligible for extended school year services that may be located at a school other than the school of residence? |
| 3. | <input type="checkbox"/> | <input type="checkbox"/> | Will the student's IEP address goals and objectives related to transportation access? |

Transportation Concerns

- | | | | |
|----|--------------------------|--------------------------|---|
| 4. | <input type="checkbox"/> | <input type="checkbox"/> | Have parents been informed of their role and responsibility in transportation of their child? |
| 5. | <input type="checkbox"/> | <input type="checkbox"/> | Does the student require adult supervision at the bus stop? If yes, parent or designee must meet the child at the stop. |
| 6. | <input type="checkbox"/> | <input type="checkbox"/> | Are there circumstances that affect the location of the pickup and/or return addresses? Specify: _____
_____ |
| 7. | <input type="checkbox"/> | <input type="checkbox"/> | Are there specific types of assistance that the bus driver or attendant must provide? If yes, specify: _____
_____ |

List any other characteristics, behaviors or needs (such as seating concerns) that may impact transportation. _____

- | | | | |
|----|--------------------------|--------------------------|---|
| 8. | <input type="checkbox"/> | <input type="checkbox"/> | If it is in the best interest of the student to provide atypical transportation services, (a vehicle other than a bus) please specify: _____
_____ |
|----|--------------------------|--------------------------|---|

Medical Concerns

To be completed in conjunction with the Nurse/Physician Assessment and/or Behavior Intervention Plan (BIP). Attach supporting documentation:

- | | | | |
|----|--------------------------|--------------------------|--|
| 9. | <input type="checkbox"/> | <input type="checkbox"/> | Does the student have a physical disability that is life threatening and requires monitoring, interpretation or intervention as determined by the site or special education itinerant nurse? |
|----|--------------------------|--------------------------|--|

10. Is the student affected by a medical condition that limits the length of time he or she is able to ride on a bus? (Attach assessment and explain.) _____

11. Does the student use technology or assistive devices such as a tracheostomy tube, use a helmet, ventilator, oxygen or frequent suctioning? Circle which, and attach assessment.
12. Does the student experience uncontrolled seizures, severe hypotonia causing potentially obstructed airway, or apnea? Circle which, and attach assessment.
13. Does the student use a walker, manual wheelchair, power wheelchair? Circle which, and indicate wheelchair width: _____
14. Is the student affected by a chronic medical condition that limits his or her ability to walk to and from school? If yes, explain: _____

15. Does the student need a child safety restraint system (CSRS)? If yes, explain: _____

16. Does the student have equipment, an assistance animal, or medication to be transported? If yes, Specify: _____

17. Does the student exhibit behavior that is aggressive or dangerous? If yes, attach copy of BIP and explain: _____

APPENDIX G
Infants, Toddlers
and
Pre-Schoolers

APPENDIX G

INFANTS, TODDLERS AND PRE-SCHOOLERS

A. Definitions: Infants, Toddlers and Pre-school Children

For the purpose of clarification, the following terms are defined:

Newborn is a child from birth to one month.

Infant is a child from one month to one year.

Toddler is a child from one year to three years.

Pre-schooler is a child from three years to five years.

Note: Individual programs may have variations in the usage of these four terms. State laws, policies and guidelines may contain variations in the age range used to define the terms infants, toddlers and pre-schooler. If not specified newborn will be included in the infant category.

B. Laws Impacting the Transportation of Infants, Toddlers, and Pre-school Children

A number of laws impact decision-making and the transportation of infants, toddlers and pre-school children. They include the following:

1. **Public Law 93-112**
The Rehabilitation Act of 1973 ('504)

This law constituted the first national declaration of the rights of individuals with handicaps. Section 504 prohibits discrimination against individuals with handicaps by any recipient of federal funding. It includes young children with a handicap who would otherwise be qualified to participate in and benefit from programs or other activities receiving federal financial assistance.

2. **Public Law 94-142**
The Education for all Handicapped Children Act of 1975

This law guaranteed that a "free appropriate public education," including special education and related services, be provided to all handicapped children. It detailed steps that must be taken in identifying and evaluating children with handicaps, provided that handicapped students must be educated with other non-handicapped students to the maximum extent appropriate in the Least Restrictive Environment (LRE), and established an elaborate system of procedural safeguards to ensure parental participation in the development and approval of the IEP. Transportation is one of the related services defined in the regulations. It is an important related service because it provides access to all other special education and related services.

3. **Public Law 97-35**
The Head Start Act ('635)

The Head Start program was initiated in 1965 as a comprehensive child development program to serve primarily low-income children. Predominately, the ages served are from three years to compulsory school attendance. However, this program has been expanded to provide services that include infants, toddlers and children with disabilities. The regulations require that a minimum of 10 percent enrollment be available to children with disabilities. While Head Start is intended to serve children from low-income families, the regulations permit up to 10 percent of the

children served be from families that are not low-income. To assist young children to reach their full potential, Head Start provides a comprehensive program that includes health, nutritional, educational, social and other services. One of the requirements of Head Start is the direct participation of parents of children enrolled.

4. **Public Law 99-372**
The Handicapped Children's Protection Act of 1986

This law amended the Education for all Handicapped Children Act of 1975 to authorize the award of "reasonable attorneys' fees" to parents who prevail in due process hearings and judicial proceedings under Part B of the Education for all Handicapped Children Act of 1975. This is extremely important because disputes that arise about the related-service transportation under Part B can result in costly recovery of attorney fees awarded by the courts to parents.

5. **Public Law 99-457, Part H**
The Education of the Handicapped Act Amendments of 1986

Within a decade of the passage of the EHA, Part H was passed to assist states in establishing statewide, comprehensive early intervention services for children with handicaps from birth through age two and their families. Based on the recognition that early intervention enhances the development of handicapped children, this law provides states with financial incentives. Borrowing from IDEA, this law requires that children receive early intervention services as specified in an Individualized Family Service Plan (IFSP). As used in this part, "developmental delay" is defined by the states. Each state must designate the criteria used to determine eligibility for services. Therefore, the types of children served under Part H programs nationwide are in part influenced by a state's definition of this population. Transportation is considered an early intervention service and is defined in the Part H regulations.

6. **Public Law 101-336**
The Americans with Disabilities Act of 1990

The Americans with Disabilities Act (ADA) is a comprehensive civil rights law that enforces the non-discrimination of persons with disabilities. It does not change or diminish existing provisions of federal law protecting individuals with disabilities under Section 504 or IDEA. The ADA creates a higher standard of non-discrimination than does Section 504 in that it applies regardless of whether federal funding is received. This law applies to all ages, including young children with disabilities. As stated in the statute, the purpose of the ADA are:

- (a) To provide a clear and comprehensive national mandate for the elimination of discrimination against individuals with disabilities;
- (b) To provide clear, strong, consistent and enforceable standards addressing discrimination against individuals with disabilities;
- (c) To ensure that the federal government plays a central role in enforcing the standards established in this Act on behalf of individuals with disabilities; and
- (d) To invoke the sweep of congressional authority, including the power to enforce the Fourteenth Amendment, and to regulate commerce in order to address the major areas of discrimination faced day to day by people with disabilities.

The ADA regulation specifically exempts school buses from some of its requirements but does not exempt access to transportation services for infants, toddlers and pre-school children.

**7. Public Law 101-476, Part B
Individuals with Disabilities Education Act of 1990**

This act renamed the Education for all Handicapped Act of 1975 as the Individuals with Disabilities Education Act (IDEA). All previous references to “handicapped children” were changed to “children with disabilities.” Transportation is defined in the regulations as a related service under the Act. In addition, two new categories of disabilities were added: “autism” and “traumatic brain injury.” The law also broadened the definition of the terms “assistive technology device” and “assistive technology service.” The addition of assistive technology service is raising questions regarding responsibility for purchase, lease, selection, adaptation, maintenance, repair or replacement of equipment under the definition of “assistive technology device.” These terms are applicable to the provision of the related service transportation.

**8. Public Law 102-119
The Individuals with Disabilities Education Act Amendments of 1991**

These amendments reauthorized P.L. 99-457, the Education of the Handicapped Act Amendments of 1986 as the Individuals with Disabilities Education Act Amendments of 1991. This reauthorization requires participating states to coordinate services and funding sources for the provision of early intervention services to infants and toddlers from birth through age two. The early intervention service transportation is defined in the regulations.

**9. Public Law 105-17
The Individuals with Disabilities Education Act Amendments of 1997**

This Act was signed into law on June 4, 1997. It is referred to as the “1997 Amendments.” The new legislation is intended to affirm and refine provisions of the prior IDEA Act. The definition of transportation as a related service under Part B remains unchanged.

C. Transportation Definitions Affecting Services for Infants and Toddlers under the Individuals with Disabilities Education Act

The definition of transportation under the Individual with Disabilities Education Act is found in P.L. 101-476 (Part B), P.L. 102-119 (Part H) and P.L. 105-117. The definitions found in P.L. 101-476 and P.L. 102-119 differ significantly in their provisions because of the ages covered under each of the statutes. The requirements of each authorization of IDEA are listed below:

**1. Public Law 101-476, Part B
Individuals with Disabilities Education Act of 1990**

The definition of transportation under the provisions of P.L. 101-476 (formerly P.L. 94-142) identifies transportation as a related service (Part B) under the IDEA regulations 300.16 and defines “transportation” as including:

- (a) travel to and from school and between schools;
- (b) travel in and around school buildings; and
- (c) specialized equipment (such as special or adapted buses, lifts, and ramps), if required to provide special transportation for a child with a disability.

**2. Public Law 102-119
The Individuals with Disabilities Education Act Amendments of 1991**

The definition of transportation under the provisions of P.L. 102-119 (formerly P.L. 99-457) identifies transportation and related costs as an early intervention service (Part H) under the IDEA regulations 303-12 (d)(15) and are defined as follows:

Transportation and related costs include the costs of travel (e.g., mileage, or travel by taxi, common carrier or other means) and other costs (e.g., tolls and parking expenses) that are necessary to enable a child eligible under this part and the child's family to receive early intervention services.

**3. Public Law 105-17
The Individuals with Disabilities Education Act Amendments of 1997**

Under the IDEA regulations 300.24(b)(15) transportation includes:

- (a) travel to and from school and between schools;
- (b) travel in and around school buildings; and
- (c) specialized equipment (such as special or adapted buses, lifts and ramps), if required to provide special transportation for a child with a disability.

Under Part C of the 1997 Amendments, Early Intervention Program for Infants and Toddlers with Disabilities, the definition of the early intervention service transportation remains unchanged.

D. National Highway Traffic Safety Administration Guideline for the Safe Transportation of Pre-school Age Children in School Buses, February 1999

This guideline provides recommendations for the transportation of pre-school age children in school buses.

Guideline for the Safe Transportation of Pre-school Age Children in School Buses
National Highway Traffic Safety Administration
February 1999

Introduction

School age children transported in school buses are safer than children transported in motor vehicles of any other type. Large school buses provide protection because of their size and weight. Further, they must meet minimum Federal motor vehicle safety standard (FMVSSs) mandating compartmentalized seating, improved emergency exits, stronger roof structures and fuel systems, and better bus body joint strength.

As more pre-school age children are transported to school programs, often in school buses, the public is increasingly asking the National Highway Traffic Safety Administration (NHTSA) about how to safely transport them. To help answer these questions, NHTSA conducted crash testing of pre-school age children in school buses are safest when transported in child safety restraint systems (CSRSs) that meets FMVSS 213, Child Restraint Systems, and are correctly attached to the seats.

Based on its research, NHTSA recommends pre-school age children transported in school buses always be transported in properly secured CSRSs. In partial response to questions from school (and child care) transportation offices, this Guideline seeks to assist school and other transportation managers in developing and implementing policies and procedures for the transportation of preschool age children in school buses.

Note: The proper installation of CSRSs necessitates that a school bus seat have safety belts or other means of securing the CSRS to the seat. NHTSA recommends that lap belts or anchorages designed to meet FMVSS 225, Tether Anchorages and Child Restraint Anchorage Systems, be voluntarily installed to secure CSRSs in large school buses.

Recommendations For the Transportation of Pre-school Age Children in School Buses

When pre-school age children are transported in a school bus, NHTSA recommends these guidelines be followed:

1. Each child should be transported in a Child Safety Restraint System (suitable for the child's weight and age) that meets applicable Federal Motor Vehicle Safety Standards (FMVSSs).
2. Each child should be properly secured in the Child Safety Restraint System.
3. The Child Safety Restraint System should be properly secured to the school bus seat, using anchorages that meet FMVSSs.

Child Safety Restraint System Defined

A Child Safety Restraint System is any device (except a passenger system lap seat belt or lap/shoulder seat belt), designed for use in a motor vehicle to restrain, seat, or position a child who weighs less than 50 pounds.

Child Safety Restraint Systems Guidelines

1. Child Safety Restraint System Specification

The provider of the CSRS should ensure:

- * Each pre-school age child to be transported has a CSRS appropriate for the child's weight, height, and age.

- * Each CSTS meets all applicable FMVSSs (look for the manufacturer's certification on the label attached to the system).
- * Each CSRS has been registered with the CSRSs manufacturer to facilitate any recalls the manufacturer might conduct.
- * If the CSRS is the subject of a recall, any necessary repairs or modifications have been made to the manufacturer's specifications.
- * Each CSRS is maintained as recommended by its manufacturer, including disposal of any CSRS that has been involved in a crash.

2. Proper Securement

The transportation provider should ensure:

- * The CSRS is used and secured correctly in the school bus.
- * Each child is secured in CSRSs according to manufacturer's instructions.
- * All CSRS attachment hardware and anchorage systems meet FMVSS 210, Seat Belt Assembly Anchorages or FMVSS 225, Tether Anchorages and Child Restraint Anchorage Systems.

School bus seats designated for CSRSs meet FMVSS 225, or include lap belts that FMVSS 209, Seat Belt Assemblies, and anchors that meet FMVSS 210 (designed to secure adult passengers or CSRS).

- * Personnel responsible for securing CSRSs onto school bus seats and children into CSRSs are properly trained and all personnel involved with CSRSs are provided up-to-date information and training.
- * When transported in the school bus, pre-school age children are supervised according to their developmental and functioning level.

3. School Bus Seats Designated for Child Safety Restraint Systems

The transportation provider should ensure:

- * School-bus seats designated for CSRSs are located starting at the front of the vehicle to provide drivers with quick access to and a clear view of the CSRS occupants.
- * CSRS anchorages on school bus seats should meet all applicable FMVSSs.
- * When ordering new school buses, the maximum spacing specified under FMVSS No. 222, School Bus Passenger Seating and Crash Protection, (within 24 inches from the seating reference point) is recommended for seats designated for CSRSs to provide adequate space for the CSRSs.
- * The combined width of CSRS and/or other passengers on a single seat does not exceed the width of the seat.
- * If other students share seats with the CSRSs, the CSRSs are placed in window seating position.

4. Retrofitting School Buses

The transportation provider should ensure:

- * Existing school bus seats should only be retrofitted with lap belts or child restraint anchorages as instructed by the school bus manufacturer.
- * When a school bus is retrofitted with a seat to allow for proper securement of a CSRS, instructions obtained from the school bus or seat manufacturer on how to install the seat and restraint systems should be followed.

- * When a school bus is retrofitted, the bus owner should ensure that seat spacing is sufficient for the CSRS to be used.

5. Evacuation

The transportation provider should ensure:

- * The establishment of a written plan on evacuating pre-school age children and other passengers in CSRSs in the event of an emergency. This written plan should be provided to drivers, monitors, and emergency response personnel. The plan should explicitly state how children (both in and out of the CSRS) should be evacuated from the school bus.
- * Evacuation drills are practiced on a scheduled basis, at least as often as that required for the school system's school-aged children.
- * All personnel involved in transporting children are trained in evacuation and emergency procedures, including those in the written school bus evacuation plan.
- * All school buses carrying children in CSRSs carry safety belt cutters that are accessible only to the driver and any monitors.
- * CSRSs are not placed in school bus seats adjacent to emergency exits.
- * Local emergency response teams are provided copies of the written school bus evacuation plan, including evacuation of pre-school age children.
- * Emergency response personnel should be invited to participate in evacuation drills.

6. Other Recommendations

The school transportation provider should establish a policy on whether they or the child's guardian must supply a CSRS to be used on a school bus. School bus purchases should be based on the needs of a projected student population, taking into consideration projected ages, sizes, and other characteristics of the students, including any special needs, and whether pre-school age children or medically fragile students will be transported.

Specified procedures should be established for loading and unloading children in CSRSs.

Procedures should be established for the periodic maintenance, cleaning, and inspection for damage of CSRSs. Procedures should be established to train personnel involved in direct service delivery of infants, toddlers, and pre-school children on the physical day-to-day handling of these young children and means to handle potential exposure to contagious and communicable diseases.

When school bus procedures are established, it should be noted that some children in CSRSs may have special needs, including medical fragility, that must be addressed on a child-by-child basis.

APPENDIX H

Resolutions

**RESOLUTION
TO THE
SPONSORING ORGANIZATIONS
(NASDPTS, NAPT, NSTA, NSC, SBMTC, AND CMSU)**

WHEREAS, the delegation of the 13th National Conference on School Transportation recognizes the importance of the document produced May 2000; and

WHEREAS, the sponsoring organizations: National Association of State Directors of Pupil Transportation Services, National Association for Pupil Transportation, National School Transportation Association, National Safety Council-School Transportation Section, School Bus Manufacturers Technical Council, and Central Missouri State University strongly urge that the Specifications and Procedures established by the 13th National Conference on School Transportation be adopted to provide the greatest passenger safety for our children; now

THEREFORE, BE IT RESOLVED that these organizations:

1. Review the progress being made toward the implementation of the Specifications and Procedures established by the 13th National Conference on School Transportation and Representative prepare for future conferences.
2. Provide copies of the proceedings of the 13th National Conference to the National Highway Traffic Safety Administration and any other agency or organization and/or individuals deemed appropriate.

**RESOLUTION
TO THE
NATIONAL HIGHWAY TRAFFIC SAFETY ADMINISTRATION**

WHEREAS, the safety and wellbeing of the students being transported to and from school and school-related activities is of paramount importance; and

WHEREAS, the yellow school bus is the safest mode of transporting our future; and

WHEREAS, we in the school transportation industry must continue to improve the high standards of school bus safety; and

WHEREAS, the National Highway Traffic Safety Administration (NHTSA) has committed their expertise in research and development aimed toward the continued improvement of the school bus; now

THEREFORE, BE IT RESOLVED that the 13th National Conference on School Transportation applaud and salute the dedication of the NHTSA staff; and

BE IT FURTHER RESOLVED that adequate funding be appropriated to effectuate their goal of providing the safest possible school bus for the youth of America; and

BE IT FURTHER RESOLVED that this Resolution shall be forwarded to the Administrator of the National Highway Traffic Safety Administration (NHTSA).

**RESOLUTION
TO THE
14th NATIONAL CONFERENCE
INTERIM AND STEERING COMMITTEE**

WHEREAS, it is important to provide continuity for the Conference; and

WHEREAS, there is a need to provide ongoing information of the proceedings and actions of the Conference; now

THEREFORE, BE IT RESOLVED that the Interim and Steering Committees for the 14th National Conference on School Transportation meet at least once a year and provide a status report to national trade publications and professional pupil transportation journals on the status of the 13th National Conference proceedings and planning for the 14th National Conference; and

BE IT FURTHER RESOLVED that there shall be no name changes to the adopted 2000 document title without the approval of a majority of the delegates when next assembled; and

BE IT FURTHER RESOLVED that the Writing and Steering Committees shall provide final documents for review to the delegates at least three weeks prior to the scheduled 14th National Conference in 2005.

**RESOLUTION
ON ADVERTISING**

WHEREAS, the unobstructed color pattern of a school bus is a nationally recognized symbol of caution to the motoring public; and

WHEREAS, advertising on school buses will expose school students to unnecessary risk by distracting motorists driving in the immediate vicinity of a school bus; now

THEREFORE, BE IT RESOLVED that the 13th National Conference on School Transportation vigorously urges the federal government, each state and U.S. Territory to develop regulations to prohibit advertising on school buses; and

BE IT FURTHER RESOLVED that copies of this resolution be transmitted to each member of the United States Congress, the Governor and the Transportation Director of every state and U.S. Territory, and the Administrator of the National Highway Traffic Safety Administration.

**RESOLUTION
OF APPRECIATION**

WHEREAS, the delegation of the 13th National Conference on School Transportation recognizes the dedication and hours of service by many individuals; now

THEREFORE, BE IT RESOLVED that the delegation:

1. Expresses appreciation to the National Association of State Directors of Pupil Transportation Services, National Association for Pupil Transportation, National School Transportation Association, National Safety Council-School Transportation Section, School Bus Manufacturers Technical Council, and Central Missouri State University for sponsoring the National Conference.
2. Expresses appreciation to Dr. Leanna Depue, associates and staff of the Missouri Safety Center; Central Missouri State University; Charlie Hood, General Conference Chairman; Dwight Carlson, On-Location Conference Chairman; and Dr. Malloy C. Gould, Parliamentarian for the excellent manner in which the Conference was organized and conducted.
3. Recognizes and expresses appreciation to members of the Interim Committee, Steering Committee and Writing Committees of the 13th National Conference for the extensive work in preparation for this Conference.

**RESOLUTION
ON
TRANSPORTING STUDENTS IN VEHICLES NOT MEETING SCHOOL BUS
DESIGN AND CONSTRUCTION STANDARDS**

WHEREAS, national research indicates that children are better protected in vehicles designed as school buses; and

WHEREAS, nationally an average of 600 school-age children are killed each year during normal school transportation hours in other vehicles; and

WHEREAS, the 13th National Conference on School Transportation considers the safety of students as their priority in not allowing other vehicles to be used to transport students to and from school and on school-related activities; and

WHEREAS, school buses are designed to meet stringent federal construction standards to protect passengers when involved in an accident; and

WHEREAS, the nation has an excellent safety record of school bus operations; now

THEREFORE, BE IT RESOLVED by the 13th National Conference on School Transportation that unnecessary danger and cost implications exist while transporting students to and from school and on school-related activities in vehicles not meeting school bus design and construction standards; and

BE IT FURTHER RESOLVED that school children should be transported only in vehicles designed as school buses; and

BE IT FURTHER RESOLVED that the 13th National Conference on School Transportation urges the adoption of federal and state law to disallow the use of vehicles other than school buses to transport children to and from school and on school-related activities; and

BE IT FURTHER RESOLVED that copies of this resolution be transmitted to each member of the United States Congress, the Governor and the Transportation Director of every state and U.S. Territory, the Administrator of the National Highway Traffic Safety Administration and the Chairman of the National Transportation Safety Board.

**RESOLUTION
ON
FUTURE PASSENGER CRASH PROTECTION
IN SCHOOL BUSES**

WHEREAS, modern school buses are the safest means of transporting pupils to and from school and school-related activities; and

WHEREAS, a small number of school bus passengers tragically are killed or seriously injured in school bus crashes each year; and

WHEREAS, the National Highway Traffic Safety Administration (NHTSA) has a research program underway to develop the next generation of passenger crash protection systems for school buses; and

WHEREAS, the National Transportation Safety Board (NTSB) has issued a Safety Recommendation to NHTSA to develop performance standards for school bus passenger crash protection systems that account for frontal, side, rear and rollover collisions; and

WHEREAS, the NTSB has issued a Safety Recommendation to NHTSA to require newly manufactured large school buses to have a passenger crash protection system that meets the new performance standards and retains passengers, including those in child safety seats, within the seating compartment throughout the crash sequence for all crash scenarios; now

THEREFORE, BE IT RESOLVED that the 13th National Conference on School Transportation supports NHTSA's research program and the NTSB's Safety Recommendations, and encourages NHTSA to devote sufficient resources to its research activities so as to ensure the resulting passenger crash protection systems for large school buses are based on adequate data and science and are completed within a timely manner.

**RESOLUTION
ON
INTELLIGENT TRANSPORTATION SYSTEMS**

- WHEREAS,** crashes involving school buses continue to occur, despite the excellent safety record of school bus transportation; and
- WHEREAS,** many children suffer mental and/or physical trauma each year as a result of crashes, and some suffer fatal injuries; and
- WHEREAS,** there exists a continuing need to improve the safety of school bus transportation, particularly with emphasis on doing so without increasing the overall cost of school bus transportation; and
- WHEREAS,** it is generally the consensus of pupil transportation professionals that the gross number of injuries and fatalities suffered by school children would be dramatically reduced by transporting most pupils to and from their homes in a school bus; and
- WHEREAS,** economic factors such as limited budgets and high operating costs are limiting factors with respect to the numbers of school children who may be afforded the opportunity to avail themselves of the relative safety of school bus transportation; and
- WHEREAS,** improvements in the operating efficiency of school bus fleets will offer the possibility of transporting more school children to and from home within the constraints of a finite budget; and
- WHEREAS,** the federal government is sponsoring research and making monetary grants available to facilitate the study of ways to utilize new and emerging technologies to improve the safety and efficiency of motor vehicle transportation through the concept known as "Intelligent Transportation Systems"; now
- THEREFORE, BE IT RESOLVED** that it is proper and desirable for elements of the school transportation industry, including manufacturers, operations specialists, maintenance specialists and others, to conduct studies and research related to the ways that existing and emerging technologies may be incorporated and integrated with all aspects of motor vehicle transportation in order to improve the safety and efficiency of school bus transportation;
- BE IT FURTHER RESOLVED** that the delegates to the 13th National Conference on School Transportation support this study and research; and
- BE IT FURTHER RESOLVED** that the national associations representing the pupil transportation industry be requested to take on the task of providing ongoing visibility of this goal and encouragement and support to those who would be involved in this endeavor.

**RESOLUTION
ON
SEPARATION OF
SPECIFICATIONS AND PROCEDURES DOCUMENT**

WHEREAS, the continued growth of the document recognizing the efforts of this Conference, the ever increasing complexities of the topics addressed, and the issues surrounding the use of this document by those outside the school bus industry; now

THEREFORE, BE IT RESOLVED THAT the Interim Committee of the 14th National Conference on School Transportation appoint an Ad Hoc Committee to review the newly adopted document and prepare a proposal for the separation of "Specifications" and "Procedures" into two documents in a manner than ensures no loss of continuity and clarity; and

BE IT FURTHER RESOLVED that the Ad Hoc Committee's proposal is to be submitted to the Interim Committee for distribution to the 14th Conference on School Transportation in a timely manner for inclusion in materials sent to the states for evaluation.

**RESOLUTION
ON
FEDERAL FUNDING FOR
NEW AND EXISTING SAFETY PROGRAMS**

- WHEREAS,** it is in the best interest of the American public to ensure that children get to school in the safest way possible; and
- WHEREAS,** it is documented and universally accepted that a yellow school bus is the safest form of ground transportation in America; and
- WHEREAS,** the exclusive use of yellow school buses for transportation to and from school and school-related activities could save as many as 600 lives every year; and
- WHEREAS,** the National Highway Traffic Safety Administration (NHTSA) provides funding for the development and dissemination of materials promoting a variety of highway safety programs including occupant protection, pedestrian and bicycle safety; and
- WHEREAS,** these materials are a positive way of increasing public understanding and participation in highway safety programs; and
- WHEREAS,** public education projects that integrate student, parent and community involvement will encourage policymakers to support the use of the nation's safest form of ground transportation and, therefore, reduce injuries and fatalities; and
- WHEREAS,** the federal government does not currently support or provide funding for any specific programs that encourage the use of the nation's safest form of ground transportation; now
- THEREFORE, BE IT RESOLVED** that the delegates to the 13th National Conference on School Transportation (NCST) direct the Chair of the Interim/Steering Committee and each of the conference's sponsoring organizations to communicate with NHTSA and other federal agencies in an effort to secure funding to promote the use of the yellow school bus as the preferred mode of transportation to and from school and school-related activities; and
- BE IT FURTHER RESOLVED,** that the Chair of the Interim/Steering Committee request funding for both new and existing school bus safety programs, such as National School Bus Safety Week, the National School Bus Safety Poster Contest, a national school bus safety speech contest, as well as other activities or programs for students, parents, schools and communities that will enable the industry to be even more effective than it is today.

**RESOLUTION
ON
LOADING AND UNLOADING SURVEY**

WHEREAS, the Kansas School Bus Safety Education Unit has been providing a valuable national survey of loading/unloading fatalities since 1970; and

WHEREAS, 72 school children lost their lives since 1995 in the loading/unloading area; and

WHEREAS, 1,046 fatalities have occurred within the loading/unloading zone since 1970, of which 58.03 percent of the 29 year totals were the result of the pupil's own school bus; and

WHEREAS, the nation's greatest resource is its children, their safety and protection are our highest priorities, and their education is our investment in the future; and

WHEREAS, extensive research using the 50 states' and Washington, D.C.'s accident reporting systems can be used to establish a national data base for tracking these results; now

THEREFORE, BE IT RESOLVED that the Kansas annual loading/unloading survey be expanded to include the following information:

- A. Non-fatal incidents in the loading/unloading areas of the school bus that result in disabling injuries.
- B. Length of disability resulting from non-fatal injuries in the loading/unloading areas of the school bus.
- C. Financial considerations for all incidents, both short-term and long-term, resulting from the injury or fatality in the loading/unloading areas of the school bus.
- D. Equipment (i.e., mirrors, warning devices, crossing arms, etc.) installed on the bus involved in any of the foregoing incidents; and

BE IT FURTHER RESOLVED that this study be conducted for the next four years, with results to be reported at the 14th National Conference on School Transportation.

**RESOLUTION
STEERING COMMITTEE**

WHEREAS, the 13th National Conference on School Transportation delegations and delegates recognize the importance of the conference document produced May 14-19, 2000; and

WHEREAS, the delegations and delegates recognize the structure and organization necessary to produce this document; and

WHEREAS, the array of experts in all areas of transportation operation and school bus construction lends itself to decentralized meetings between conferences to develop recommendations for industry-wide improvements; and

WHEREAS, current technology enhances communication without the need for extended meetings; now

THEREFORE, BE IT RESOLVED that the Interim and Steering Committee for the 14th National Conference on School Transportation consider the following:

1. Select a meeting room that will provide space for all delegations to assemble in an area that does not isolate any delegation and to allow all delegates and delegations to hear and see deliberations adequately.
2. Devise a procedure for clearance through the Technical Committee, when appropriate, to expedite the presentation and disposition of amendments on the floor.
3. Encourage writing committees and delegations to prepare for deliberations by a pre-determined date.
4. Use appropriate technology (video cameras, large screen monitors, etc.) to enhance participants' comprehension of issues (proposals and amendments) that are under consideration.
5. Schedule interim meetings of writing committees between conference dates as a venue for perpetually developing recommendations for revisions and to better prepare delegates for the tasks to be accomplished at the conference.
6. Explore the use of electronic voting tabulations.

**RESOLUTION
ON
UNIFORM INCIDENT REPORTING
FOR STUDENT TRAVEL**

WHEREAS, the 13th National Conference on School Transportation is in agreement with the concept and recognizes the importance of collecting information on student-related incidents and injuries; and

WHEREAS, a uniform reporting system would assist in providing a foundation for effective traffic safety programs of the future; and

WHEREAS, the Special Writing Committee's initial development of a uniform reporting procedure presented during the 13th National Conference on School Transportation establishes the groundwork for future data collection; and

WHEREAS, the momentum and further development should continue during the interim; now

THEREFORE, BE IT RESOLVED by the 13th National Conference on School Transportation that the Accident Report Writing Committee, Interim Committee and the Steering Committee of the 14th National Conference on School Transportation coordinate with other national organizations that may benefit from student injury data.

**RESOLUTION
ON AIR BAGS**

WHEREAS, the 13th National Conference on School Transportation is in agreement that crash impact safety system improvement is desirable in the driver station area; and

WHEREAS, side and/or steering column air bags may offer significant improvement to this area; and

WHEREAS, nonetheless, no current technology systems are available to implement enhancements to this area; now

THEREFORE, BE IT RESOLVED by the 13th National Conference on School Transportation that an appropriate Federal agency research the benefits of enhanced safety systems in the driving station area for all Commercial Motor Vehicles (CMV) and that the said agency report its finding to the 14th National Conference on School Transportation and take appropriate interim action as required.

The said report, is to include, but is not limited to:

- * Identification of injury/fatality data suffered by CMV operators.
- * Evaluation of whether or not equipment enhancement of operator station safety systems is warranted.
- * Conference with appropriate technology industries to evaluate specifications, costs and benefits.

Committees

**13th National Conference
on School Transportation**

**Conference Committee
List**

**13th National Conference on School Transportation
Conference Committee List**

* Chair

Steering Committee

*Charlie Hood	Robert Douglas
Randy McLerran	Carroll Pitts
George Ed Donn	Pete Baxter
Donald Fowler	Bill Loshbough
Leanna Depue	Dennis Hammell
Donald Tudor	Nancy Schulz
Wilbur Rumph	Tom Turner

General Operations Writing Committee

*Doug Snyder	Jim Ridley
Mike Brown	Rick Soules
Beth Jennings	Pete James

Body Writing Committee

*Bill Schroyer	Mike Kinney
Danny Thede	Marshall Casey
Steve Mann	Ron Marion
Rod Nash	Ron Briggler
Joe Scesny	Ed Turner
Chuck Stevenson	Mike Sykes
Charles Hott	

Bus Chassis Writing Committee

*Carroll Pitts, Jr.	Mike Roscoe
Glen Huffman	Carlisle Beasley
Robert Pudlewski	Bob Wigginton
Vernon Wright	Harry Owen
Dan Herman	Denny Coughlin
Joseph Netto III	Wayne Johnston

Special Needs Operations Committee

* Alexandra Robinson	Kellie Dean
Linda Fultz	Kathleen Furneaux
Peter Grandolfo	Ted Maas
Lois Mantelli	Nick Sanders
Chuck Shinn	Thomas Vasko

Non-School Bus Use Writing Committee

*John Edney	Ron Kinney
Barbara Goodman	Charley Kennington
Charles Bishop	Ned Einstein

Terms and Definitions Writing Committee

* Robin Leeds	Vernon Wright
Roseann Schwaderer	Knowles Smith
Timothy Flood	Frank Stanhope

Resolutions Committee

*Bill Loshbough	Technical Advisors
Bette Norris	Charles Gauthier - NASDPTS
Jerry Milliken	Mike Martin - NAPT
Gilbert Perea	Karen Finkel - NSTA

Accident Reporting Writing Committee

*Donald Paull	Ted Finlayson-Schueler
Bob Hensley	

Infants, Toddlers and Pre-Schoolers Writing Committee

*Linda Bluth	Brenda Bridge
Tom Casey	Nancy Cleeves
Ruby Cordova	Kentin Gearhart
Rayette Hudon	Wes Keever
Jerry Milliken	Darnese H. Nicholson
Luzanne Pierce	Alexandra Robinson
Mike Roscoe	Sue Shutrump
Kathy Strotmeyer	Harold Tsosie
Jean Zimmerman	

Editing Committee

*Barbara Goodman	Bette Norris
Charles Hood	Donald Tudor
George Horne	Charlie Gauthier

School Bus Inspection Writing Committee

*Bob Painter	Joe Scesny
Craig Powell	Jim Brunet
Sharon VanCampen	Mark Marino
Deborah Lincoln	Tony Buechter
David Sluder	Larry Sherman
Bob Pudlewski	Donald Fowler
Glenn Carriker	

Technical Assistance Committee

*Donald Fowler	Bob Pudlewski
Lori Messer	Robert Douglas
Dan Drexler	Tom Turner

Special Needs Bus Writing Committee

* Michael Wagner	Peter Grandolfo
Tami Fowler	Betty Cotzin
Sue Ireland	Nancy Ranquist
Barbara Mackey	Judith Marks
Kristine Smith	Jean Zimmerman
Janet Kerr	Tom Bever
Jan Dittbrenner	

Roster

13th National Conference on School Transportation

Delegate and Alternate List

**13th National Conference on School Transportation
Official Delegate and Alternate List
*Delegation Chair**

Alabama (D5)(Alt 0)

*Joe Lightsey
Greg Ray
John Rudd
Bryan Nash
Darrin McBay

Alaska (D6)(Alt)

*Joe Precourt
Steve Kalmes
Bob Wheelon
Dennis Cook
Scott Schwald
Charles MacDonald

Arizona (D4)(Alt 0)

*William Kohn
Ignacio Fernandez "Nacho"
Jeff Lambert
Harry Yogurtian

Arkansas (D7)(Alt 0)

*Spence Holder
Fred Davis
Dave Floyd
Rickey Smith
Norbert Novak
Howard Pearson
Nathan Barber

California (D7)(Alt 2)

*Robert Austin
Doug Snyder
Dano Rybar
Ken McCoy
Mike Ellis
Bob Wigginton
Ron Kinney

California (cont.)

Alternates
Nikki Hughes
Alexandra Robinson

Colorado (D7)(Alt 0)

*Bruce Little
Mary Thompson
Scott Benefield
Joe Mirabella
Marvin Shipley
Bob Robbins
Dave Sullivan

Connecticut (D3)(Alt 0)

*Art Vogel
Harry Gough
Robin Leeds

Delaware (D7)(Alt 0)

*Ron Love
Jeff Viar
Don Hartwig
Ken Becker
Lee Dean
George Middleton
Wendell Davis

Florida (D7)(Alt 2)

*Charles Hood
Ronnie McCallister
Don Crawford
Sonya Olliff
Jerry Klein
Hugh Mills
Robert Veres
Alternates
Linda Fultz
Chuck Stevenson

Georgia (D7)(Alt 0)

- *Sam McCullough
- Carlton Allen
- Ed Donn
- Carroll Pitts, Jr.
- Cpl. T. A. Peebles
- Jack Brock

Idaho(D7)(Alt 0)

- *Rodney McKnight
- Ray Merical
- Virginia Overland
- Kevin Seamons
- Dick Krasselt
- Vern Carpenter
- Paul Hawkins

Illinois (D6)(Alt 0)

- *Alvida Petro
- Jo Ann Wilson
- Carol Harper-Falconer
- Tony Klasing
- Michael Wagner
- Tom Casey

Indiana (D7)(Alt 0)

- *Pete Baxter
- Gene Moore
- Mike Mentzel
- Dennis Petticord
- Susan Reynolds
- Patricia Gregory
- Judith Dahlstrom

Iowa (D7)(Alt 0)

- *Terry Voy
- Verlan Vos
- Owen Freese
- Danny Thede
- Marvin Adcock
- Stewart French
- Harold Knutsen

Kansas (D7)(Alt 1)

- *Larry Bluthardt
- James Helton
- Lora Rozeboom
- Katie Sholander
- Ray Ramirez
- Barbara Pringle
- Debora Romine

Alternate

- Jack Woolf

Kentucky (D7)(Alt 0)

- *Mike Roscoe
- Dave Mangum
- Bobby Sheroan
- Thomas Bach
- Darrell Sea
- Howard Mayes
- Bobby Gaffney

Louisiana (D1)(Alt 0)

- *George Horne

Maine (D6)(Alt 0)

- *Harvey Boatman
- Ronald Deegan
- Don Foster
- Joseph Larrabee
- Barry Moores
- Rayette Hudon

Maryland (D6)(Alt 1)

- *Donald Lafond
- Winship Wheatley
- Mark Dreszer
- Jim Doolan
- Paul Welch
- Glenn Johnson

Alternates

- Linda Bluth

Massachusetts (D6)(Alt 0)

*Judith Dupille
Clifton Johnson
George Jones, III
Peter Crossan
Richard Jacobs
Kenneth Jenkins

Michigan (D5)(Alt 0)

*Susan Anderson
Annie Zesiger
William Tousley
Matthew Losch
Tim Hofmeister

Minnesota (D5)(Alt 0)

*Duane Bartels
Ken Spanier
Jan Dittbrenner
Rob Sloan
Denny Coughlin

Mississippi (D2)(Alt 0)

*Leonard Swilley
William Carter

Missouri (D7)(Alt 2)

*David Decker
Stephanie Brooks
Debra Clink
David Perkins
Jerry Sides
Jerry Wright
Bill Whitfield

Alternates

Shirley Francis
David Wilson

Montana (D4)(Alt 0)

*Gordy Conn
Steve Klippenes
David Huff
Peter Grandolfo

Nebraska (D7)(Alt 0)

*Arthur Keller
Jerald Loewe
David Wolfe
Jean Mann
Russ Inbody
Mary Kitzmiller
Mark Dickinson

Nevada (D5)(Alt 0)

*Kevin Curnes
Craig Falconer
Steve Clifford
Marvin Thiessens
Thomas Wilson

New Hampshire (D5)(Alt 0)

*Percy Abbott
Terry Tibbetts
David Hardy
Richard Lilly
Philip Dail

New Jersey (D6)(Alt 0)

*Mark Marino
Linda Wells
Joanne Gouvain
Timothy Wallace
Harold Zofcin
Dennis Hammell

New Mexico (D6)(Alt 0)

*Gilbert Perea
Dale Bohn
Frank Silva
Carlos Santiago
Robert Coleman
Bill Loshbough

New York (D7)(Alt 7)

*Marion Edick
Joseph Scesny
Joan Corwin
Robert Pape

New York (Continued)

Leonard Bernstein
James Reitmeier
Patricia Bailey

Alternates

Gary Catapano
David Kennedy
Pete James
Dona Beauchea
Kathy Furneaux
Ted Finlayson-Schueler
Robert Peters

North Carolina (D7)(Alt 0)

*Derek Graham

Phillip Benton
Don Byrnes
Spencer Glenn
Floyd Jackson
Harold Laffin
David Sluder

Ohio (D5)(Alt 0)

*Pete Japikse

Bob Painter
Dave Kauffman
Dave Decsman
Claudia Fowler

Oklahoma (D5)(Alt 0)

*Randy McLerran

Randy Ann Stickney
Jack Jerman
Jim Taylor
John Linville

Oregon (D7)(Alt 0)

*Deborah Lincoln

Paul Treglown
Dennis Essary
John Fairchild
Mac Pennington
Steve Hendrickson
Dave Voiles

Pennsylvania (D7)(Alt 0)

*Stephen Madrak

Selina Pittenger
Roger Rittenhouse
Warren Levy
Mike Hurley
Gail Wolfel
Thomas Zamboni

Rhode Island (D5)(Alt 0)

*Walter Kettelle

Charlotte 'Cookie' Gabrielson
William Langlois
Ernest Gardiner
Amy Stewart

South Carolina (D3)(Alt 0)

*Donald Tudor

Marshall Casey
Aubrey Williams

South Dakota (D6)(Alt 0)

*Dennis Johnston

Ron Block
Tim Steichen
Albert Graham
Marlet Graue
Jim Shafer

Tennessee (D4)(Alt 0)

*Larry Riggsbee

Jack Johnson
Keith Phillips
Danny Hickman
Frederick Wells

Texas (D7)(Alt 0)

*Walter Prothro

Mike McClung
Carl Kirst
Charley Kennington
Jack Irvin
Bob Hensley
Mike Patterson

U.S. Territory-Guam (1)

*Mark Kelley

Utah (D6)(Alt 0)

*Brent Huffman

Zane Woolstenhulme

Wayne Reese

Bill Lundin

Greg Lundell

David Schiers

Vermont (D4)(Alt 0)

*Gerald McNamara

Bob King

Kevin Endres

Cary Bessette

Tom Urell

Virginia (D6)(Alt 0)

*Barbara Goodman

Vince Nevius

Tom Williams

Velera Gammons

Harold Grimes

Warren Carter

Washington (D7)(Alt 0)

*Mike Kenney

Sue Carnahan

G. Reg Clarke

Randy Millhollen

Dick Swigert

Rick Lecker

Les Harris

West Virginia (D1)(Alt 0)

*Jerry Milliken

Wisconsin (D5)(Alt 0)

*Robert Christian

Angeline Kamba

Peter Parsons

Phillip Fey

Tom Westlund

Wyoming (D6)(Alt 0)

*D. Leeds Pickering

Kirk Schmidt

Knowles Smith

Ed Turner

Randy Jensen

Dennis Wegner

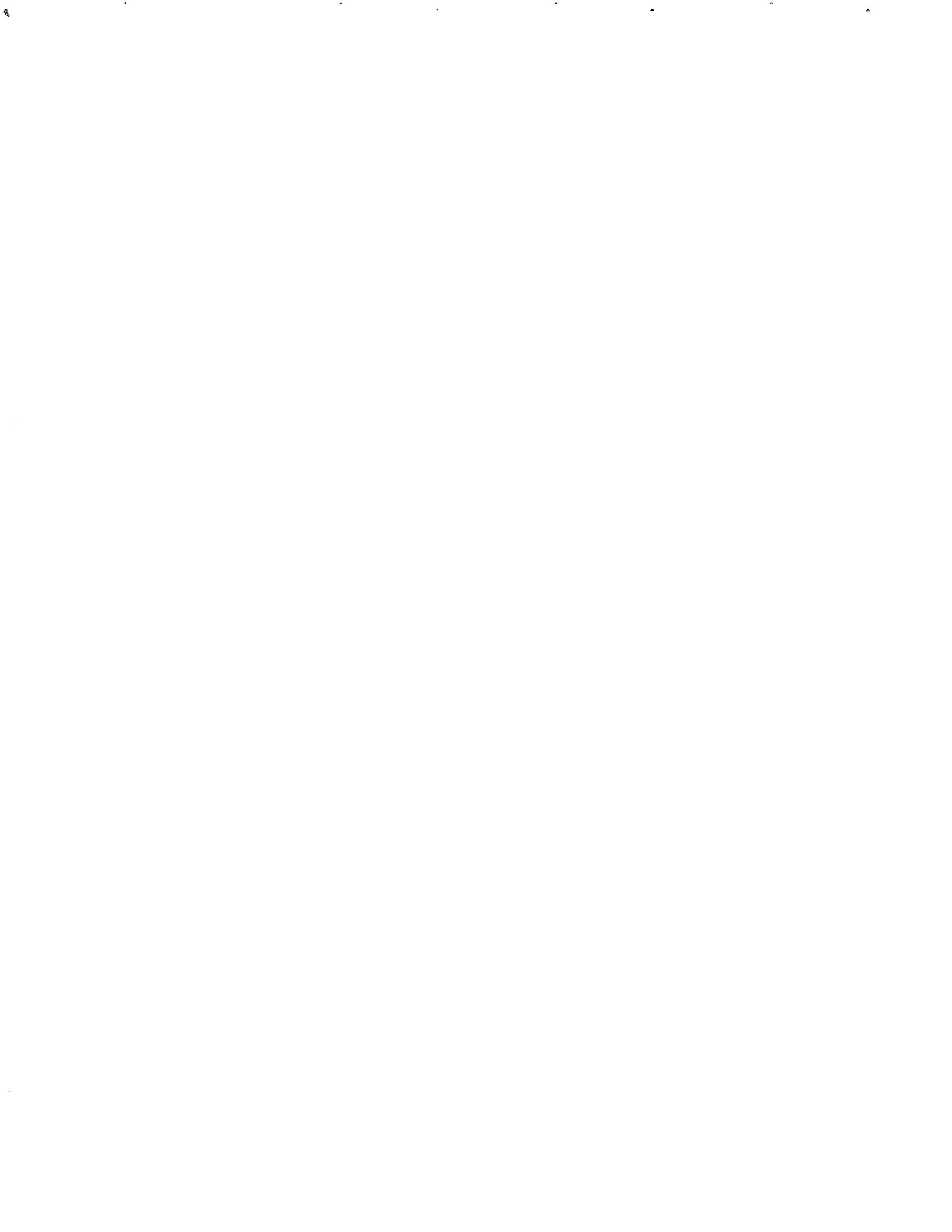

Roster

13th National Conference Delegate and Alternate List

13th National Conference on Pupil Transportation - Attendance Roster

Percy Abbott
Human Resource Officer
Laidlaw
51 Lowell Rd
Salem, N.H. 03079

Marvin Adcock
Iowa Pupil Trans Assoc
206 Evergreen St.
Shenandoah, IA 51601

Kenneth W Allen
Staff Technician
Blue Bird Body Company
402 N. Camellia Blvd
Ft. Valley, GA 31030

T. Carlton Allen
Director of Transportation
Forsyth County Schools
3710 Matt Highway
Cumming, GA 30040

Susan Anderson
Director
MI Dept. of Ed, Office of School Support Serv
P.O. Box 30008, 608 Allegan 4th Floor
Lansing, MI 48909

David Anderson
Fleet Manager
Cherry Creek Schools
16500 E. Smoky Hill Rd
Aurora, CO 80015

Tim Anderson
Aftermarket Coordinator
MICO Incorporated
1911 Lee Boulevard
North Mankato, MN 56003

Robert Austin
Bus Driver Training Program Spec.
CA Dept. of Education
3500 Reed Ave.
W. Sacramento, CA 95605

Robert L. Baldwin
Director Emeritus
Missouri Safety Center
CMSU Humphreys 201
Warrensburg, MO 64093

Thomas Bach
Director of Transportation
Kenton County Board of Education
20 Kenton Lands Road
Erlanger, KY 41018

Patricia Bailey
Transportation Supervisor
Brewster Central Schools
40 Farm to Market Rd.
Brewster, NY 10509

Nathan Barber
Assistant Superintendent
Newport School District
406 Wilkerson Dr.
Newport, AR 72112

Sgt. Duane Bartels
Commercial Vehicle Inspector
Minnesota State Patrol
1110 Centre Point Curve Ste 410
Mendota Heights, MN 55120

G. W. "Pete" Baxter
Director Div of School Traffic Safety
Ind. Dept of Ed
229 State House
Indianapolis, IN 46204-2798

Carlisle Beasley
Carlisle Beasley & Associates
4723 Bento Smith Road
Nashville, TN 37215

Dona M. Beauchea
Safety Director
Laidlaw Transit, Inc.
RR 1 Box 77 B
West Coxsackie, NY 12192

Kenneth Becker
Transp Supervisor
Sussex Vo Tech School Dist
Rt. 9, P. O. Box 351
Georgetown, DE 19947-0351

Scott Benefield
Transportation Director
Douglas County School District
2808 N. Highway 85 Building B
Castle Rock, CO 80104

Phillip Benton
Transportation Director
Stokes County Schools
P. O. Box 50
Danbury, NC 27016

Leonard Bernstein
President NYAPT
Haverstraw-Ston Point Schools
65 Chapel St.
Garnerville, NY 10923

Carey Bessette
Vice President
Wildcat Busing
154 Route 15W
Hardwick, VT 05843

Ron Block
Contractor/Manager
Box 419
Webster, SD 57274

Linda Bluth
Branch Chief
Div of Ed. Early Intervention Ser.-Special Ed.
200 W. Baltimore St.
Baltimore, MD 21201

Larry E. Bluthardt
State Director
Kansas Board of Education
120 S.E. 10th Ave
Topeka, KS 66612-1182

Harvey Boatman
Transportation Construction Spec.
Maine Department of Education
23 SHS
Augusta, ME 04333-0023

Dale Bohn
Regional Director
Helweg and Farmer Transportation Co.
10200 Bell Ave SE
Albuquerque, NM 87123

Gregory Bridgeman
General Mgr.
Speciality Mfg Co
P.O. Box 790
Pineville, NC 28134

Ron Briggler
Specification Engineer
AMTRAN Corp
P.O.Box 6000
Conway, AR 72033

Jack Brock
Director of Transportation
Baldwin Co Schools
P. O. Box 1188
Milledgeville, GA 31061

Stephanie Brooks
Supervisor
Administrative Services DESE
P.O. Box 480, 205 Jefferson
Jefferson City, MO 65102

Corky Bynum
Vice President
Safety System & Controls, Inc.
2400 Campbell Road #H
Houston, TX 77080

Don Byrnes
Transportation Director
Cleveland County Schools
300 Kemper Rd
Shelby, NC 28150

Dwight R. Carlson
Administrator Div. of Voc. Rehab. Ser.
Iowa Department of Ed
510 E. 12th Street
Des Moines, IA 50319

Don Carnahan
Director of Market Development
Laidlaw
20131 SE 192nd St.
Renton, WA 98058

Sue Carnahan
Director
Office of Superintendent of PE
P.O. Box 47200
Olympia, WA 98504

Vern Carpenter
Co-Owner
Brown Bus Company
2023 E. Sherman
Namapa, ID 83686

Warren L Carter
Director of Fleet Maintenance
Albermarle
110 Lambs Rd
Charlottesville, VA 22901

William C. Carter
Supervisor, Pupil Trans. Field Services
359 North West St.
Jackson, MS 39201

Marshall Casey
Asst Director Transportation
SC Dept of Ed
1429 Senate Street Rm 209
Columbia, SC 29201

Thomas Casey
General Mgr
Crawford Bus Service
18962 Airport Rd
Lockport, IL 60441

Gary J. Catapano
Director of Operations
The Transportation Group L.L.C
50 Court St
Copiague, NY 11726

Robert Christian
Acting State Director
Wisconsin Dept of Ed
1015 Erie Ave
Sheboygan, WI 53081

G. Reg Clarke, CDPT
Program Director
Edmonds School District 015
3009 Alderwood Mall Blvd
Lynnwood, WA 98036

Steve Clifford
Transportation Supervisor
Lyon County School District
25 E. Goldfield Ave
Yerington, NV 89447

Debra Clink
Transportation Consultant
MO. Dept. of Secondary & Elem. Ed.
P.O. Box 480, 205 Jefferson
Jefferson City, MO 65102

Robert Coleman
School Transportation Director
Los Lunas Schools
P.O. Drawer 1300
Los Lunas, NM 87031

Gordy Conn
Director of Pupil Transportation
Montana Dept of Ed
P.O. Box 202501
Helena, MT 59620-2501

Dennis Cook
Transportation Coordinator
Fairbanks N. Star Borough School Dist
520 5th Ave
Fairbanks, AK 99701-4756

Joan Corwin
President, NYSBCA
Chappaqua Trans, Inc.
130 Hunts Ln.
Chappaqua, NY 10514

Denny Coughlin
Supervisor
Minnesota Department of Ed
1001 2nd Ave N.
Minneapolis, MN 55405

Don Crawford
Director of Transportation
Volusia Dist School Board
P.O. Box 2118
Deland, FL 32721-2118

Peter Crossan
Coastal Bus & Equipment
P.O. Box 752
Rowley, MA 01960

Kevin Curnes
Director Transportation
Carson City School District
P.O. Box 603
Carson City, NV 89702

Wanda B Curtis
Specifications Engineer
Thomas Built Buses
1408 Courtesy Rd P.O. Box 2450
High Point, NC 27260

Judy Dahlstrom
District Area Mgt
Laidlaw Transit, Inc
8775 Zionsville Rd
Indianapolis, IN 46268

Phil Dail
Owner
Dail Transportation
Rt. 107 Box 428
Epsom, NH 03234

Fred Davis
President
Arkansas School Bus Mech Asso
P.O. Box 382
Prescott, AR 71857

Wendell Davis
Bus Contract Manager
Ryder Student Transportation Service Inc.
950 Stanton-Christiana Rd
Newark, DE 19713

Jane Dawson
Regional Sales Manager
Thomas Built Buses
P.O. Box 2450
High Point, NC 27261

C. Lee Dean
Transportation Supervisor
Lake Forest School Dist
5423 Killens Pond Rd
Felton, DE 19943-9801

Dave Decker
Superintendent
Lincoln School Dist
P.O. Box 39
Lincoln, MO 65338

Dave Decsman
Director of Transportation
Toledo City School
5600 Hill Ave
Toledo, OH 43615

Ronald Deegan
Transportation Director MSAD 17
1570 Maine St. Suite 11
Oxford, MA 04270

Leanna Depue
Director
Missouri Safety Center
CMSU Humphreys 201
Warrensburg, MO 64093

Mark Dickinson
Admin Assistant
Blair Com. Schools
140 S. 16th St. Box 288
Blair, NE 68008

Jan Dittbrenner
Transportation Coordinator
TIES
1925 West County Rd B2
Roseville, MN 55113-2791

Gary O. Dixon
Director of School Governance
Mo. Dept of El & Second Ed
P.O. Box 480
Jefferson City, MO 65102-0480

Ken Dodson
Vice President
Thomas Built Buses, Inc.
1408 Courtesy Rd P.O. Box 2450
High Point, NC 27261

George E. Donn
Vice Chair-NCST
Whitfield County Schools
P.O. Box 2167
Dalton, GA 30722

Jim Doolan
Supervisor of Pupil Trans
Carroll County Schools
125 North Court St.
Westminster, MD 21157

Mark J Dreszer
Foreman II/ Garage Operations
Board of Education of P.G. County
13300 Old Marlboro Pike
Upper Marlboro, MD 20772

Judith A Dupille
Asst. Director Vehicle Inspection
Dept Reg of Motor Vehicles
One Copley Place
Boston, MA 02116

Marion Edick
State Director
NYSED
Room 876 EBA
Albany, NY 12234

John R. Edney
Business Development Affairs
National Express Corp
9011 Mountain Ridge Dr. Suite 200
Austin, TX 78759-7222

Mike Ellis
California Highway Patrol
Commercial Vehicle Sec.
P.O. Box 942898
Sacramento, CA 94298-0001

Kevin Endres
VT School Trans Assoc
C10 30 Cherry St.
Milton, VT 05468

Dennis Essary
Supervisor of Transportation
Beaverton School District
10420 S.W. Allen Blvd.
Beaverton, OR 97008

John Fairchild
Salem-Keizer School District
998 Hawthorne Ave. NE
Salem, OR 97301

Craig Falconer
Asst Transportation Director
Washoe County School District
1850 Kleppe Lane
Sparks, NV 89431

Nacho Fernandez
Transportation Director
Fowler School District
1617 South 67th Ave
Phoenix, AZ 85043

Phil Fey
President
Student Transit
1001 Menomonie St.
Eau Claire, WI 54703

Karen E Finkel
Executive Director
NSTA
625 Slaters Lane Suite 205
Alexandria, VA 22314

Ted Finlayson-Schuler
Executive Director
Pupil Transportation Safety Institute
443 S. Warren St.
Syracuse, NY 13202

Peter Finn
Consultant
PLF Consultants
P.O. Box 6571
Fort Drake, NY 12206

Richard Fischer
President
Trans Consult
11465 Dallas Rd
Peyton, CO 80831

Dave Floyd
Plant Manager
Arkansas Dept of Ed
#4 Capitol Mall
Little Rock, AR 72201

Don Foster
Transportation Director
MSAD 51
P.O. Box 6A
Cumberland, ME 04021

Donnie Fowler
President
Fowler Bus Company
1213 East Main St.
Richmond, MO 64085

Tami Fowler
Customer Specification Analyst
AMTRAN Corp
P.O. Box 6000
Conway, AR 72033

Claudia Fowler
Supervisor of Transportation
1837 Harshman Rd
Dayton, OH 45424

Shirley Francis
Director
Special School Dist St. Louis Co
12110 Clayton Rd
St. Louis, MO 63131

Owen Freese
Dept of Ed
Grimes State Building
DesMoines, IA 50319

Stewart French
IPTA
Jefferson-Scranton CS 601 Lincoln Way
Jefferson, IA 50129

Linda Fultz
Transportation Director
Citrus Dist School Board
1007 West Main St.
Inverness, FL 34450

Kathleen Furneaux
Program Associate
Pupil Transportation Safety Inst
443 South Warren St.
Syracuse, NY 13202

Charlotte Gabrielson
Manager
Laidlaw Transit, Inc
404 Main St.
Pascoag, RI 02859

Bobby Gaffney
Director of Transportation
Woodford Co Board of Ed
131 Maple St.
Versailles, KY 40383

Velera C. Gammons
Director of Transportation
Henry Co Schools
119 Cossman
Collinsville, VA 24078

Harry Gough
Department Engineer
Conn DMV
22 Meadow St.
East Hartford, CT 06108

Ernest Gardiner
Director of Transportation
Town of Narragansett
55 Mumford Road
Narragansett, RI 02882

Malloy Gould
Coordinator of Publications
CMSU Missouri Safety Center
Humphreys 201
Warrensburg, MO 64093

Joanne Gauvain
Transportation Coordinator
Manchester TWP BOE
121 Route 539
Whiting, NJ 08759-1237

Albert Graham
Transportation Coordinator
800 N.E. 9th Street
Madison, SD 57042-1199

Spencer Glenn
Transportation Director
Forsythe County Schools
4150 Carver School Rd
Winston Salem, NC 27105

Derek Graham
Senior Chief
NC Dept of Instruction
301 N. Wilmington St.
Raleigh, NC 27601

Mel Globerman
Chief Vehicle Engineering Branch
General Services Adm
GSA Office
Washington , DC 20406

Peter Grandolfo
Manager Safety & Special Needs
Chicago Public Schools
125 S. Clark St.
Chicago, IL 60603

Barbara Goodman
Chesterfield County Dept. of Public Trans.
10201 Courthouse Rd.
Chesterfield, VA 23832

Marlet Graue
Transportation Supervisor
301 S. Splitrock Blvd
Brandon, SD 57005-1651

John I. Goss
Regional Manager
Q'Straint
9975 E. Creek St.
Tucson , AZ 85730

Patricia Gregory
Director of Transportation
Crown Point Schools
200 East North St.
Crown Point, IN 46307

Harold F Grimes Jr.
Director of Transportation
Henrico County Public Schools
3820 Nine Mile Road
Richmond, VA 23223

Jim Haigh
Vice President of Manufacturing
Transpec Worldwide
7205 Sterling Ponds Court
Sterling Heights, MI 48312

Joe Haley
Clarksville-Montgomery Co Schools
2620 Madison St.
Clarksville, TN 37043

Dennis Hammell
Owner
Village Bus Company
P.O. Box 442
Sparta, NJ 07871

David Hardy
Transportation Manager
Concord School District
311 N. State St.
Concord, NH 03301

Carol Harper-Falconer
Lake County State Instr.
Lake County Reg. Superintendant
328 Rye Rd.
Mundelein, IL 60069

Les Harris
Director of Transportation
Cheney School District
2736 N. 6th
Cheney, WA 99004

Don Hartwig
Transportation Supervisor
Colonial School District
1617 Matassino Rd
New Castle, DE 19720-2086

Paul Hawkins
Transportation Supervisor
Teton Co. School District #401
40 Flying Saddle Rd. P.O. Box 775
Driggs, ID 83422

Janet Hazlett
Program Specialist
National Safety Council
1121 Spring Lake Dr.
Itasca, IL 60143

Ken Hedgecock
Director of Sales
Thomas Built Buses
P.O. Box 2450
High Point, NC 27275

James W. Helton
Director of Transportation
Unified School Dist No.494
Box 966
Syracuse, KS 67878

Steve Hendrickson
Area Maintenance Mgr.
First Student, Inc.
1936 N.E. Lafayette Ave
McMinnville, OR 97128-9331

Bob Hensley
Transportation Director
Crowley ISD
P.O. Box 688
Crowley, TX 76036

Dan Herman
Bus Marketing Manager
International Truck & Engine Corp
455 N. City Front Plaza Drive
Chicago, IL 60540

Danny Hickman
Giles County Schools
720 West Flouers
Pulaski, TN 38478

Steve Hirano
Editor
School Bus Fleet Magazine
21061 S. Western Ave
Torrance, CA 90501

Timothy Hofmeister
Director of Operations
Kalamazoo Reg Ed Svc. Agency
1819 E. Milham Rd
Kalamazoo, MI 49002

Spence Holder
Transportation Coordinator
AR Dept. of Education
#3 Capital Mall Room 209 -D
Little Rock, AR 72201

Charlie Hood
Director School Trans Mgt
Florida Dept of Ed
325 West Gaines St. Ste 824
Tallahassee, FL 32399-0400

George Horne
Southeast Regional Manager
PTSI
5017 Bissonet Drive
Metairie, LA 70003-1013

Charles Hott
Safety Engineer
N.H.T.S.A.
400 7th Street S.W. - NPS - 12
Washington, DC 20590

Rayette Hudon
Executive Director
ME Asso. For Pupil Trans
P. O. Box 7828
Portland, ME 04112

Beverly Huey
Senior Program Officer
TRN / National Acad of Sciences
2101 Constitution Ave NW
Washington DC 20418

David Huff
Director of Traffic Education
P.O. Box 202501
Helena, MT 59620-2501

Brent Huffman
Pupil Transportation Specialist
Utah State Office of Education
250 E. 500 St
Salt Lake City, UT 84111

Nikki Hughes
Director of Transportation
San Juan Unitted School Dist
3738 Walnut Ave, 23 Devri Court
Sacramento, CA 95608

Mike Hurley
Administrator of Mngmt. Services
Carlisle Area School Dist
623 W. Penn St.
Carlisle, PA 17013

Russ Indody
Director of School Finance
Nebraska Department of Ed
301 Centennial Mall South Box 94987
Lincoln, NE 68509-4487

Jack Irvin
Transportation Director
Huffman ISD
24403 FM 2100, P.O. Box 2390
Huffman, TX 77535-2390

Floyd Jackson
Driver Edu Specialist
DOT/DMV SB & Traffic Safe
1100 New Bern Ave
Raleigh, NC 27697

Richard Jacobs
Director Transportation Unit
Boston Public Schools
26 Court St.
Boston, MA 02108

K. H. "Pete" James
Chautauqua Transportation Services
P.O. Box 1100
Chautauqua, NY 14722

Pete Japikse
State Director
Ohio Department of Ed
65 S. Front St. Room 815
Columbus, OH 43215

Lt. Kenneth Jenkins
Mass State Police
RMV 630 Washington St
Boston, MA 02111

Randy Jensen
Transportation Director
Lincoln County #2
389 Adams 222 E. 4th Ave.
Afton, WY 83110

Darrel Jensen
Director NB Safety Center
University of NB at Kearney
Mens Hall UNK
Kearney, NE 68849

Jack Jerman
Supt of Schools
Amber-Pocassett Schools
P.O. Box 38
Amber, OK 73004-0038

Glenn Johnson
Supervisor of Transportation
Howard County Public Schools
10910 Rt 108
Ellicott City, MD 21043

Jack Johnson
Hamilton County Dept. of Ed.
2501 Dodds Ave
Chattanooga, TN 37407

Wayne B. Johnston
Director of Transportation
Springfield Public S.D.
1901 E. Paper Mill Road
Oreland, PA 19075

Clifton Johnson
Northeast Regional
Laidlaw Transit, Inc.
175 Dwight Road, Ste 202
Longmeadow, MA 01106

Dennis Johnston
Asst Program Manager
SD Department of Ed
Kneip Build, 700 Governors Dr
Pierre, SD 57501-2291

George P. Jones, III
Pupil Transportation Sup
Lawrence Public Schools
P. O. Box 1498
Lawrence, MA 01842

Steve Kalmes
Transportation Director
Anchorage School District
3580 E. Tudor Rd
Anchorage, AK 99507

Angie Kamba
Director of Transportation
New London Schools
901 W. Washington St.
New London, WI 54961

David L Kauffman
Mechanics Bellefontaine City Schools
120 W. Lake Ave.
Bellefontaine, OH 43311

Art Keller
Supervisor Transportation
York Public Schools
2918 N. Delaware Ave.
York, NE 68467-9502

Mark S. Kelly
Student Transportation Spec
DDESS- Gaum
PSC 490 Box 7655
FPO, AP 96538-1600

David Kennedy
Transportation Supervisor
Sweet Home CSD
1741 Sweet Home Rd
Amherst, NY 14228

Mike Kenney
Regional Transportation Coord
State of Washington
33 S. Second Ave
Yakima, WA 98902

Charley Kennington
Program Specialist
Texas Department of PS
1617 East Crest Dr
Waco, TX 76705

Walter D. Kettelle
Supervisor of Transportation
Town of N. Kingstown
100 Fairway Dr.
N. Kingstown, RI 02852

Robert King
Highway Safety Coordinator
Government Highway Safety
5 Park Row
Waterbury, VT 05676

Ron Kinney
Director
Laidlaw Educational Services
8651 Elk Ridge Way
Elk Grove, CA 95624

Teresa Kinney
Sales and Marketing Manager
Certified Safety Mfg
1400 Chestnut
Kansas City, MO 64127

Carl Kirst
Transportation Director
Victoria ISD
P.O. Box 1759
Victoria, TX 77902

Erhard Kostler
Manager Chassis Engineering
Thomas Built Buses, Inc.
1408 Courtesy Rd P.O. Box 2450
High Point, NC 27260

Mary Kitzmiller
Trainer
Transportation, Bellevue Public Schools
1601 Kay Lynn Drive
Bellevue, NE 68005

Dick Krasselt
Transportation Supervisor
Moscow School District #281
650 N. Cleveland
Moscow, Idaho 83843

Tony Klasing
IDOT, Vehicle Inspection Unit Mgr.
3215 Executive Park Drive, P.O. Box 19212
Springfield, IL 62794-9212

Harold Laflin
Transportation Director
Buncombe County Schools
74 Washington Ave.
Asheville, NC 28804

Jerry Klein
Director of Transportation
Miami-Dade Dist School Board
15401 SW 117th Ave
Miami, FL 33177

Donald Lafond
Chief Pupil Transportation
Maryland Department of Education
200 W. Baltimore St.
Baltimore, MD 21201

Steve Klippenes
Transportation Director
School Dist. #1 Lewistown
215 7th Ave South
Lewistown, MT 59457

Jeff Lambert
Transportation Director
Chino Valley Elementary School
P.O. Box 225, 115 N. Hwy 89
Chino Valley, AZ 86323

Harold Knutson
Superintendent
Western Dubuque Community School
Box 279
Farley, IA 52046

William Langlois
School Bus Advocate
846 Middlebridge Road
Wakefield, RI 02879

William Kohn
Transportation Director
Scottsdale Unified School District
9288 E. San Salvador
Scottsdale, AZ 85258

Joseph Larrabee
Supervisor Bldgs & Trans
MSAD 75
50 Republic Dr.
Tobsham, ME 04086

David Lear
Director of Fleet
Kindercare Learning Centers
650 N.E. Holiday Drive
Portland, OR 97232

Rick Lecker
Transportation Manager
Longview School Dist
2080 38th Ave.
Longview, WA 98632

Robin Leeds
Executive Director
COSTA
135 Day St.
Newington, CT 06111-1244

Warren Levy
President
Levey School Bus Company
114 E. Broad St. P.O. Box 580
Trumbauersville, PA 18970

Joe Lightsey
Administrator
50 N. Ripley St Room 5303
Montgomery, AL 36104

Dick Lilly
Sales Manager, School Lines , Inc.
P.O. Box 1
Durham , NH 03824-0001

Deborah Lincoln
Director, Dept of Education
255 Capital N.E.
Salem, OR 97310-0203

John Linville
Director of Transportation
Mid-Del Public Schools
607 W. Rickenbacker
Midwest City, OK 73110

Bruce Little
Sr Transportation Consultant
Colorado Department of Education
201 E. Colfax Ave.
Denver, CO 80203

Jerald Loewe
Supervisor Transportation
Wisner Pilger School
801 18th St. Box 580
Wisner, NE 68791

Matthew Losch
Director Pupil Transportation
220 Lamson St.
Grand Ledge, MI 48837

Bill Loshbough
Transportation Consultant
School Services & Leasing
1022 Bell Ave SE
Albuquerque, NM 87123

Ronald Love
State Supervisor
Department of Education
P.O. Box 1402
Dover, DE 19903

Greg Lundell
Sergeant
Utah Highway Patrol
4501 S 2700 W
Salt Lake City, UT 84119

Bill Lundin
Director of Transportation
Washington School District
189 W. Tabernacke
St. George, UT 84770

Chuck MacDonald
Arctic Star Inc.
512 W. 6th Ave #4
Anchorage, AK 99501

Stephen J. Madrak
Manager
Special Driver Programs
1101 S Front St 3rd Floor
Harrisburg, PA 17104

David Mangum
Program Consultant
Kentucky Dept of Education
500 Mero St 15th Floor
Frankfort, KY 40601

Steve Mann
Specification Coordinator
Blue Bird Body Company
PO Box 937 402 N Camellia Blvd.
Fort Valley, GA 31030

Jean Mann
Supervisor of Transportation
Lincoln Public Schools
2200 Park Blvd
Lincoln, NE 68502

Mark Marino
Supervisor I
New Jersey Division of Motor Vehicles
225 E State St PO Box 177
Trenton, NJ 08666-0177

Ron Marion
Specifications Manager
Thomas Built Buses Inc.
1408 Courtesy Rd
Highpoint, NC 27263

Howard Mayes
Director of Transportation
Owsley Co. Board of Education
PO Box 340
Booneville, KY 41314

Mark McAlpine
Director of Sales and Marketing
Transpec Worldwide
7205 Sterling Ponds Court
Sterling Heights, MI 48312

Darin McBay
SE Maintenance Supervisor
Laidlaw Transit
4120 Jake Road
Huntsville, AL 35802

Ronnie McCallister
Director of Operations, Audits and Safety
Florida Dept. of Ed
325 W Gaines St Suite 825
Tallahassee, FL 32399-0400

Mike McClung
Executive Director of Transportation
Northeast ISD
10333 Broadway
San Antonio, TX 78217

Ken McCoy
Chief Executive Officer
Antelope Valley Transportation Agency
670 West Ave L-8
Lancaster, CA 93534

Sam McCullough
Director, Pupil Transportation
GA Dept. of Education
1666 Twin Towers East
Atlanta, GA 30334

Dave McDonald
Sales Mgr.
Rosco Mirrors
144-31 91st Ave
Jamaica, NY 11435-4397

Lori Messer
Director of Transportation
Moore County Schools
PO Box 945
Carthage, NC 28327

Charles McDonald
Artic Star, Inc.
510 W. 6th Ave.
Anchorage, AK 99501

George Middleton
Transportation Supervisor
Red Clay School District
479 Old Airport Rd
New Castle, DE 19720-1099

Rodney D. McKnight
Sup. Support Ser.
Id. Department of Ed.
650 W. State St. 2nd Fl.
Boise, ID 83720-0027

Bill Milby
Vice President Engineering
Blue Bird Body Company
PO Box 937 402 N Camellia Blvd.
Ft. Valley, GA 31030

Randy McLerran
Director of Transportation
Oklahoma State Dept of Education
2500 N. Lincoln Blvd
Oklahoma City, OK 73105-4599

Bruce Miles
Chief Engineer
Blue Bird Body Company
PO Box 937 402 N Camellia Blvd.
Ft. Valley, GA 31030

Gerald McNamara
Chief of Education and Safety
Vermont Dept of Motor Vehicles
120 State St
Montpelier, VT 05603-0001

Randy Millhollen
Region 2 Transportation Manager
ESD 121
5804 20th St E
Fife, WA 98512

Mike Mentzel
Assistant Director of Transportation
Evansville-Vanderburgh Schools
300 SE 8th St
Evansville, IN 47713

Jerry Milliken
Director of Transportation
Roane County Schools
108 Chapman Ave
Spencer, WV 25276

Ray Merial
Specialist Pupil Transportation
Idaho Dept of Education
PO Box 83720
Boise, ID 83720-0027

Hugh Mills
Director of Transportation
Suwannee County School Board
1727 SW Walker St.
Live Oak, FL 32060

Joe Mirabella
Director of Transportation
Cherry Creek Schools
16500 Smoky Hill Rd
Aurora, CO 80015

Alton E. "Gene" Moore
Director of Transportation
Indianapolis Public Schools
935 N Carrolton Ave
Indianapolis, IN 46202

Barry Moores
Trooper/MSP
Maine Association for Pupil Transportation
PO Box 1091
Raymond, ME 04071

Rod Nash
VP Engineer
Collins Industries Inc.
15 Compound Dr.
Hutchinson, KS 67502

Bryan Nash
Administrator
Alabama State Dept of Ed
50 N Rippley St. Rm 5303
Montgomery, AL 36104

Davis Nelson
Deputy State Superintendent of Schools
Georgia Dept of Education
205 Butler St Suite 1766
Atlanta, GA 30334

Vince E. Nevius
Association Specialist
PTS/DOE
101 N 14th St. PO Box 2120
Richmond, VA 23219

Ruth Newby
President
TransPar Group
6201 College Suite 333
Overland Park, KS 66211

Bette Norris
VP Driver Development Safety
Laidlaw Transit
55 Shuman Blvd Suite 400
Naperville, IL 60563

Norbert Novak
Head Mechanic
Marshall School District
PO Box 310
Marshall, AR 72650

Sonya Olliff
Director of Transportation
Hardee District School Board
PO Drawer 1678
Wahchula, FL 33873

Virginia Overland
Transportation Supervisor
Lake Pend Oreille #84
1700 Baldy Mtn Rd
Sandpoint, ID 83864

Robert A Painter
Ohio State Highway Patrol
1970 W Broad St. 4th Fl
Columbus, OH 43223

Robert Pape
President
Lawrence Public Schools
PO Box 477
Lawrence, NY 11559

Jim Parris
Vice-President
TransPar Group
6201 College Suite 333
Overland Park, KS 66211

Peter Parsons
Transportation Director
Montello School District
3600 52nd St.
Kenosh, WI 53144

Mike Patterson
Operations Director
Corpus Christi ISD
6530 Ranger Dr.
Corpus Christi, TX 78415

Bill Paul
Publisher & Editor
School Transportation News
P.O. Box 789
Redondo Beach, CA 90277

Donald G. Paull
President
Capital Bus Sales & Service of Texas, Inc.
PO Box 143625
Austin, TX 78714-3625

Buck Pearce
Sales Mgr.
Specialty
PO Box 790
Pineville, NC 28134

Howard Pearson
Transportation Supervisor
Fort Smith School District
PO Box 1948
Fort Smith, AR 72902

T.A. Cpl Peebles
School Bus Safety Unit
Georgia State Patrol
4800 US 84 B7-Pass
Thomasville, GA 31792

Mac Pennington
Supervisor
Lake Oswego Public School District 7J
PO Box 70
Lake Oswego, OR 97034-0070

Gilbert Perea
State Transportation Director
New Mexico State Dept of Education
300 Don Gaspar
Sante Fe, NM 87501

David P. Perkins
Assistant Director of Transportation
Missouri State Highway Patrol
1510 East Elm St.
Jefferson City, MO 65102

Robert Peters
Transportation Director
Liverpool Central School District
4101 Longbranch Rd
Liverpool, NY 13090

Alvida Petro
State Director of Pupil Transportation
Illinois State Board of Education
100 N First St.
Springfield, IL 62777

Dennis Petticord
Education Consultant
Indiana Dept of Education
Indiana Dept of Ed Room 229 State House
Indianapolis, IN 46204-2798

Bryce Pfister
Director of Engineering
Collins Bus Corporation
PO Box 2946
Hutchinson, KS 67504-2946

Keith Phillips
Director of Transportation
336 Woody Crest Ave
Nashville, TN 37210

D. Leeds Pickering
Program Manager
Traffic Safety/Pupil Transportation
2300 Capital Ave, 2nd Floor
Cheyenne, WY 82002-0050

Selina Pittenger
Administrative Assistant
PA School Bus Association
355 N 21st St., Suite 200
Camp Hill, PA 17011

Carroll Pitts, Jr.
Director of Transportation
Cobb County School District
620 S. Cobb Dr
Marietta, GA 30060

Joe Precourt
State Director
Alaska Dept of Education
801 W 10th St Suite 200
Juneau, AK 99801

Barbara J. Pringle
Assistant Director of Transportation
USD 253
PO Box 1504
Emporia, KS 66801-1504

Walter Prothro
Program Specialist
Texas Education Agency
1701 N Congress Ave
Austin, TX 78701-1494

Robert T. Pudlewski
VP of Fleet Service Management
Laidlaw Transit, Inc.
301 Cayuga Rd, Suite 200
Buffalo, NY 14225

Sheri Quinn
Product Line Manager-Commercial Products
Weldon Technologies, Inc.
3656 Paragon Dr.
Columbus, OH 43228

Ramon Ramirez
Consultant
Kansas State Dept of Education
120 SE 10th St.
Topeka, KS 66612-1182

Greg Ray
Safety Inspection Coordinator
Alabama State Dept of Education
50 N Rippley St. Rm 5303
Montgomery, AL 36104

Wayne Reese
Transportation Supervisor
Cache County School District
2063 N 1200 East
North Logan, UT 84341

James Reitmeier
Transportation Supervisor
Lancaster Central School
295 Pleasant View Dr.
Lancaster, NY 14086

Susan Reynolds
Director of Transportation
Penn-Harris-Madison Schools, Corp.
3205 N. Home St
Mishawaka, IN 46545

Larry Riggsbee
Director of Pupil Transportation
Sumner County Board of Education
850 Industrial Blvd
Gallatin, TN 37066

Roger Rittenhouse
President, PA School Bus Assoc.
Rittenhouse Bus Lines Inc.
280 Smock Rd
Smock, PA 15480

Bob Robbins
Transportation Director
Colorado Dept of Education
13990 Bradshaw Rd
Peyton, CO 80831

Curt Roberts
General Manager
TransPar Group
6201 College Blvd Suite 333
Overland Park, CA 66211

Alexandra Robinson
Director of Transportation
San Diego Unified Schools
4710 Cardin St.
San Diego, CA 92111

Debora L. Romine
School Bus Safety Consultant
Kansas State Dept of Education
120 SE 10th St.
Topeka, KS 66612-1182

Mike Roscoe
State Director of Pupil Transportation
Kentucky Dept of Education
15th Floor CPT 500 Mero St.
Frankfort, KY 40601

Rhonda Rowe
School Finance Accountant
Nebraska Dept of Education
301 Centennial Mall South Box 94987
Lincoln, NE 68509-4987

Lora Rozeboom
Director of Special Education
Tri-County Special Services
1022 Kansas
Larned, KS 67550

John Rudd
Transportation Supervisor
Russell County Board of Education
169 Seale Rd
Seale, AL 36875

Dano Rybar
Bus Driver Training Specialist
California Dept of Education
3500 Reed Ave
West Sacramento, CA 95605

Nick J. Sanders
Safety Manager
Stock Transportation
320 Bloomington Rd West
Aurora, Ont. Canada L46-4J9

Carlos Santiago
School Transportation Director
Santa Fe Public Schools
610 Alta Vista St.
Santa Fe, NM 87501-4197

Joesph Scesny
Supervising Motor Vehicle Inspector
NYSDOT
4 Burnet Blvd NYSDOT
Poughkeepsie, NY 12603

Dave Schiers
Utah Highway Patrol Safety Inspection
Utah Highway Patrol
4501 S 2700 W
Salt Lake City, UT 84119

Kirk Schmidt
Business Manager
Carbon County School District #1
P.O. Box 160
Rawlins, WY 82301

Bill Schroyer
Director Fleet Management
Florida Dept of Education
824 Turlington Bldg
Tallahassee, FL 32399

Nancy Schulz
Regional Safety Manager
Laidlaw Education Services
1548 E 23rd St. Suite C
Lawrence, KS 66046

Scott Schwald
Pupil Transportation Supervisor
Matanuska-Susitna Borough School District
PO Box 87308
Wasilla, AK 99687

Darrell Sea
Director of Transportation
Anderson County Board of Education
103 N Main St
Lawrenceburg, KY 40342

Kevin Seamons
Transportation Supervisor
Preston School District #201
513 E 1st St.
Preston, ID 83263

Jim Shafer
Manager
School Bus Inc.
5100 W 8th St.
Sioux Falls, SD 57107

Bobby Sheroan
Director of Transportation
Hardin County Board of Education
110 Main St.
Elizabethtown, KY 42701

Marvin Shipley
Transportation Supervisor
P.O. Box 1671
Montrose, CO 81402

Katie M. Sholander
Transportation Supervisor
USD 443
PO Box 460
Dodge City, KS 67801

Jerry Sides
Manager
School Services and Leasing
3350 Morgan Ford
St. Louis, MO 63116

Frank Silva
Capitan Transportation, Inc.
PO Box 185
Capitan, NM 88316

Rob Sloan
Transportation Director
Independent School District #318 Grand Rapids
820 NW 1st Ave
Grand Rapids, MN 55744-2687

David Sluder
Transportation Consultant
NC Dept of Public Instruction
127 Lakeview Acres Dr.
Asheville, NC 28806

Knowles Smith
Director of Transportation
Teton Co. School District #1
225 S. Cache Box 568
Jackson Hole, WY 83001-0568

Ricky Smith
Head Mechanic
Pine Bluff School District
PO Box 7678
Pine Bluff, AR 71611

Doug Snyder
Superintendent of Schools
Kern County School District
1300 17th St.- City Centre
Bakersfield, CA 93301

Ken Spanier
MN School Bus Operators Association
21984 St Hwy 15
St. Cloud, MN 56301

Tim Steichen
Transportation Supervisor
Watertown School District 14-4
200 9th St. NE
Watertown, SD 57201

Chuck Stevenson
Assistant Director of Transportation
Brevard District School Board
2091 W King St.
Cocoa, FL 32926

Amy Stewart
Region Safety Manager
Ryder/First Student
3 Ricom Way
Providence, RI 02909

Randy Ann Stickney
Superintendent of Schools
Ninnekah Public Schools
PO Box 275
Ninnekah, OK 73067-0275

Dave Sullivan
Transportation Director
Weld County School District RE-4
P.O. Box 609
Windsor, CO 80550-0609

Scott Summers
Legal Counsel II
Nebraska Dept of Education
301 Centennial Mall South, Box 94987
Lincoln, NE 68509-4987

Dick Swigert
Commercial Vehicle Enforcement Officer
WA State Patrol
PO Box 42614
Olympia, WA 98504-2614

Leonard C. Swilley
Director Pupil Transportation
Office of Safe and Orderly Schools
359 North West St.
Jackson, MS 39201

Michael Sykes
Business Development Manager
Carpenter Industries, Inc.
1100 Industries Rd
Richmond, IN 47374

Jim Taylor
In-House Supervisor
Tulsa Public Schools
1815 N 77th E Ave
Tulsa, OK 74115

Gary L. Teal
Specification Coordinator
Blue Bird Body Company
PO Box 937 402 N. Camellia Blvd
Ft. Valley, GA 31030

Danny Thede
IPTA Indianola Community School
1204 E Ashland Ave
Indianola, IA 50125

Marvin Thiessens
Maintenance Shop Supervisor
Washoe County School District
1850 Kleppe Lane
Sparks, NV 89431

Mary Thompson
Transportation Consultant
Colorado D.O.E.
201 E. Colfax
Denver, CO 80203

Terry Tibbetts
Administrator, Safety and Driver Ed.
NH Dept of Education
101 Pleasant St
Concord, NH 03301

William Tousley
Transportation Supervisor
Farmington Public Schools
32500 Shiawassee St.
Farmington, MI 48336

Paul Treglown
Consultant
Oregon Dept of Education
255 Capitol St NE
Salem, OR 97310-0203

Daniel Trexler
Engineering Manager
Thomas Built Buses, Inc.
1408 Courtesy Rd
High Point, NC 24261

Donald Tudor
Director of Transportation
Dept. of Transportation SC
Dept. of Education
1429 Senate St. Room 209A
Columbia, SC 29201

Tom Turner
Manager Engineering Services
Blue Bird Body Company
PO Box 937 402 N. Camellia Blvd
Ft. Valley, GA 31030

Ed Turner
Transportation Director
Weston County School District #1
P.O. Box 929
Newcastle, WY 82701

Tom Urell
Traffic Engineering Supervisor
National Life Building, Drawer 33
Montpelier, VT 56033

Gary Van Etten
Sr. Motor Carrier Specialist
NTSB
1515 W. 190th Street Suite 555
Gardena, CA 90248

Terry Van Lear
President
Van Lear Equipment
2718 Bernville Rd
Reading, PA 19605-9448

Bob Veres
Director
Clay District Schools
900 Walnut St.
Green Cove Springs, FL 32043

Jeff Viar
Transportation Supervisor
Brandywine School District
3101 Edgemoor Ave
Wilmington, DE 19802-2407

Arthur Vogel
Inspector
CT Dept of Motor Vehicles
Commercial Vehicle Safety Division
60 States St.
Wethersfield, CT 06161

Dave Voiles
501 SE 2nd St.
Bend, OR 97702-1667

Verlan Vos
IA Dept of Education
Grimes State Office Building
Des Moines, IA 50319

Terry Voy
Iowa Dept. of Education
Grimes State Office Building
Des Moines, IA 50319

Michael Wagner
Manager
Alpha School Bus Company
4702 W Midlothian Turnpike
Crestwood, IL 60445

Tim Wallace
President
Rahway Bus Co
445 Inman Ave
Colonia, NJ 07067

Dennis Wegner
Transportation Technician
Park County School District #1
160 N Everts
Powell, WY 82435

Paul Welch
Executive Director
Maryland School Bus Contractor's Assoc.
PO Box 427
Forest Hill, MD 21050

Fred Wells
Director
East Tennessee Assoc. for Pupil Transportation
c/o Oak Ridge Schools
PO Box 6588
Oak Ridge, TN 37831

Linda Wells
Director Office of Pupil Transportation
NJ Dept of Education
100 Riverview Plaza Rt 29 Box 500
Trenton, NJ 08625-0500

Tom Westlund
President
Westlund Bus Lines Inc
PO Box 691
Marionette, WI 54143

H. Winship Wheatley, III
Transportation Supervisor
Anne Arundel County Public Schools
2644 Riva Rd
Annapolis, MD 21401

Bob Wheelon
Transportation Manager
North Slope Borough School District
PO Box 169
Barrow, AK 99723

Bill Whitfield
MO Division of Highway Safety
1510 E Elm St
Jefferson City, MO 65109

Robert Wigginton
Transportation Director
Rowland Unified School District
1010 Otterbein St
Rowland Heights, CA 91748

Aubrey Williams
County Supervisor
SC Dept of Education
PO Box 253
Fairforest, SC 29336

Tom Williams
Transportation Supervisor
Washington County School Board
812 Thompson Dr
Abingdon, VA 24210

Tom Wilson
Transportation Supervisor
Elko County School District
PO Box 1012
Elko, NV 89803

JoAnn Wilson
Legislative Liaison
Illinois Sec of State/Driver Services Dept
2701 South Dirksen Parkway
Springfield, IL 62723

David Wilson
Sales Consultant
Central States Bus Sales, Inc.
2450 Cassens Dr
St. Louis, MO 63026

David Wolfe
Director of Student Transportation
Omaha Public Schools
3833 N 72nd St
Omaha, NE 68134-4403

Gail Wolfel
Transportation Director
IU 20
6 Dansforth Dr
Easton, PA 18045-7899

Jack Woolf
Area Marketing Manager
Midwest Bus Sales, Inc.
313 E Front St
Bonner Springs, KS 60012

Zane Woolstenhulme
Business Administrator
South Summit School District
375 E 300 S
Kamas, UT 84036

Vernon Wright
Staff Engineer
Blue Bird Body Company
PO Box 937 402 N. Camellia Blvd
Ft. Valley, GA 31030

Jim Wright
Transportation Director
Horry County Public School District
1600 9th Ave
Conway, SC 29526

Jerry Wright
Director of Transportation
Liberty Public Schools
300 Bluejay Dr
Liberty, MO 64068

Harry Yogurtian
Director of Transportation
Pendergast Elementary School District #92
3802 N 91st Ave
Phoenix, AZ 85037

Thomas Zamboni
Manager Regulation Analysis
1101 S Front St 3rd Floor
Harrisburg, PA 17104

Annie Zesiger
Director of Pupil Transportation
Rockford Public Schools
7109 Northland Dr.
Rockford, MI 49341

Harold Zofcin
Director of Transportation
Randolph TWP Board of Education
School House Rd
Randolph, NJ 07869-3199

